

Products & Technology

Amana S-Series Installation and Commissioning
Technical Training Module TRV-6.1



Rest assured.
It's an Amana® brand.



© 2022 Daikin Comfort Technologies North America, Inc.
Amana® is a registered trademark of Maytag Corporation or its related companies and is used under license.
All rights reserved.



Disclaimer

This material provides technical information that is to only be used by appropriately trained and certified HVAC-R installers and technicians who have agreed to the terms and conditions available here at <https://www.daikincity.com/DaikinCityB2BTermsOfUse.html>. If you have not agreed to these terms and conditions, you may not use or view this material, and you assume responsibility for any injury or property, system or equipment damage which may result. If you have agreed to these terms, you also agree, by viewing or using this material, that this material, by its nature, cannot include a discussion of everything necessary to effect a proper installation or repair of HVAC-R equipment, nor can it address every possible scenario or environment a technician or installer may encounter. Accordingly, this material should not be considered as recommendations for best practices and will not be considered installation or repair instructions to the extent of any conflict with Daikin- or Goodman-issued manuals and specifications, or industry standards and regulations. Each installer or technician remains fully responsible for ensuring proper installation or repair of the HVAC-R equipment being worked on, and you remain fully responsible for any injury or property, system or equipment damage which may result from your installation. ©2022 Daikin Comfort Technologies North America, Inc., all rights reserved; recording, copying, or distribution of this material is prohibited without express written permission from Daikin.

Amana® is a registered trademark of Maytag Corporation or its related companies and is used under license. All rights reserved.

Agenda

Product and Accessories

Inverter Technology

Indoor Units

Nomenclature

A	S	X	S	6	S	3	6	1	0	A	A
1	2	3	4	5	6	7	8	9	10	11	12



Brand
A – Amana

Product Category
S - Split System R-410A

Unit Type
X – Condenser
Z – Heat Pump

Feature
S – Side Discharge

SEER 2

3 – 13.4-13.7	7 – 16.6-17.5
4 – 13.8-14.5	8 – 17.6-18.5
5 – 14.6-15.5	9 – 18.6-19.5
6 – 15.6-16.5	0 – 19.6+

Minor Rev

A – Initial release

Major Rev

A – Initial release

Variation

4 – Standard Variant

Electrical

1 – 208/230 V, 1 Phase, 60 Hz

Nominal Capacity

18 – 1.5 Tons	42 – 3.0 Tons
24 – 2.0 Tons	48 – 4.0 Tons
30 – 2.5 Tons	60 – 5.0 Tons
36 – 3.0 Tons	

Sales Region

S – Southeast & North
0 – All Regions





ASXS6****0A*

- Small chassis: 1.5-3-ton models (ASXS60***0A* only)
- Large chassis: 3.5-5-ton models (ASXS6S****AA only)
 - Utilizes a cooling loop to cool the inverter control board during operation
- Variable speed swing compressor in all models
- Digitally commutated outdoor fan motor
- Boost mode
- Coil and ambient temperature sensors
- Suction pressure transducer
- Utilizes Amana Smart Thermostat
- Improved cooling performance at high ambient temperature (115°F)
 - 5.0-ton only

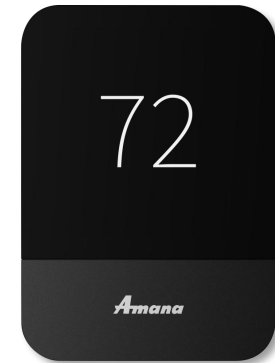



ASZS6****AA

- Small chassis: 1.5-3-ton models
- Large chassis: 3.5-5-ton models
 - Utilizes a cooling loop to cool the inverter control board during operation
- Variable speed swing compressor in all models
- Digitally commutated outdoor fan motor
- Boost mode
- Coil, defrost and ambient temperature sensors
- High/low pressure transducer
- Utilizes Amana Smart Thermostat

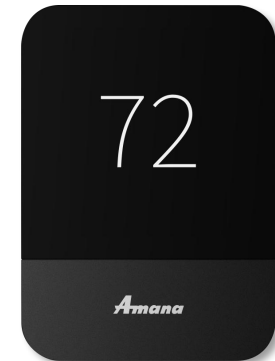



Voltage separation requirements

- Voltage separation is a requirement per UL 1995.
- **Low voltage:** All sensors, communication cables including thermostat cable.
- **High Voltage:** Main power, compressor and fan power, power to sub boards, and power conditioners.
- Maintaining wire routing after servicing any inverter air conditioner is very important.

Note: Before contacting the inverter board, power down the unit and verify that the measurement between C+ C- in 50 vdc or less.

Low
Voltage



High
Voltage

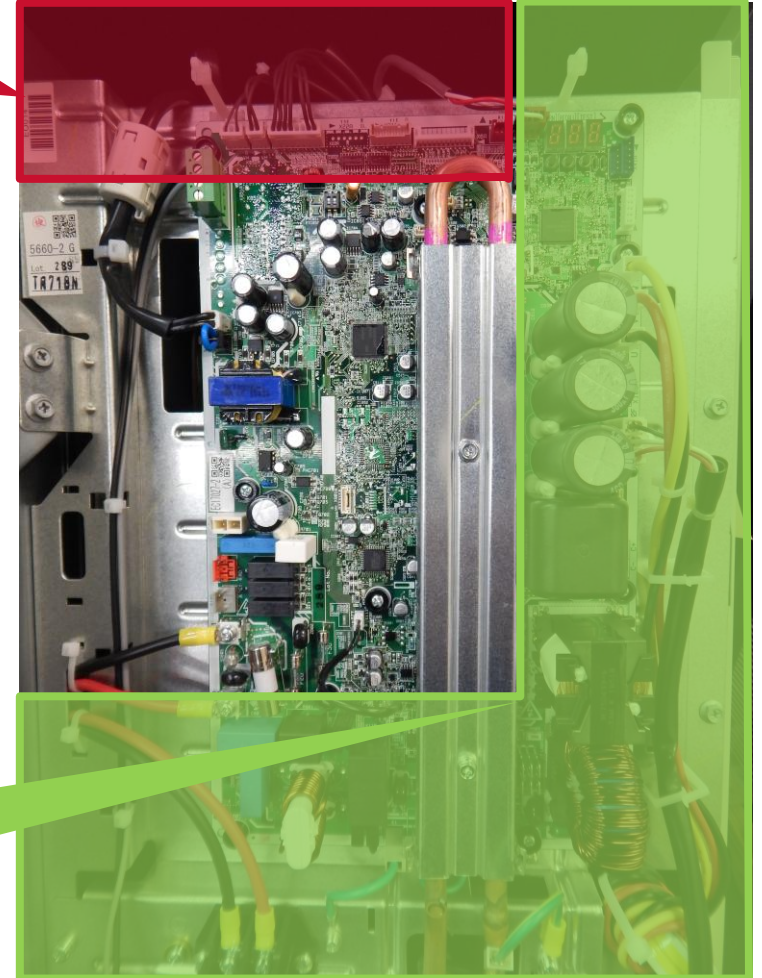

PCB (1.5-3-ton)



Main PCB

Service PCB



Solenoid coil
(Heat pump)



D-Checker
port

Condenser
fan

Ambient
thermistor

Defrost and
coil thermistor

Discharge, liquid, and
suction thermistor

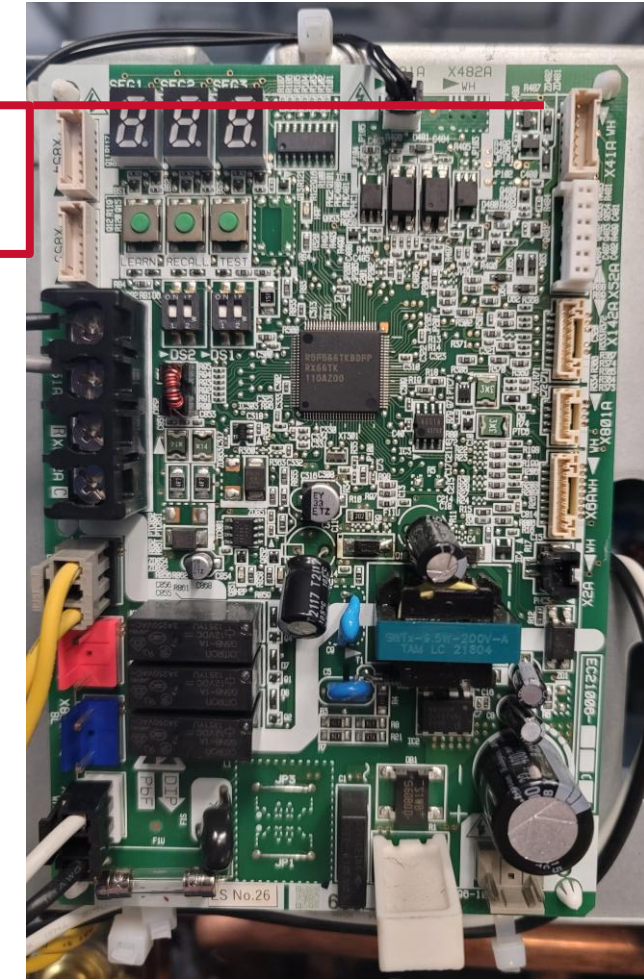

Smaller chassis models (1.5 - 3Ton) utilize a heat sink behind PCB.

PCB (3.5-5 ton)

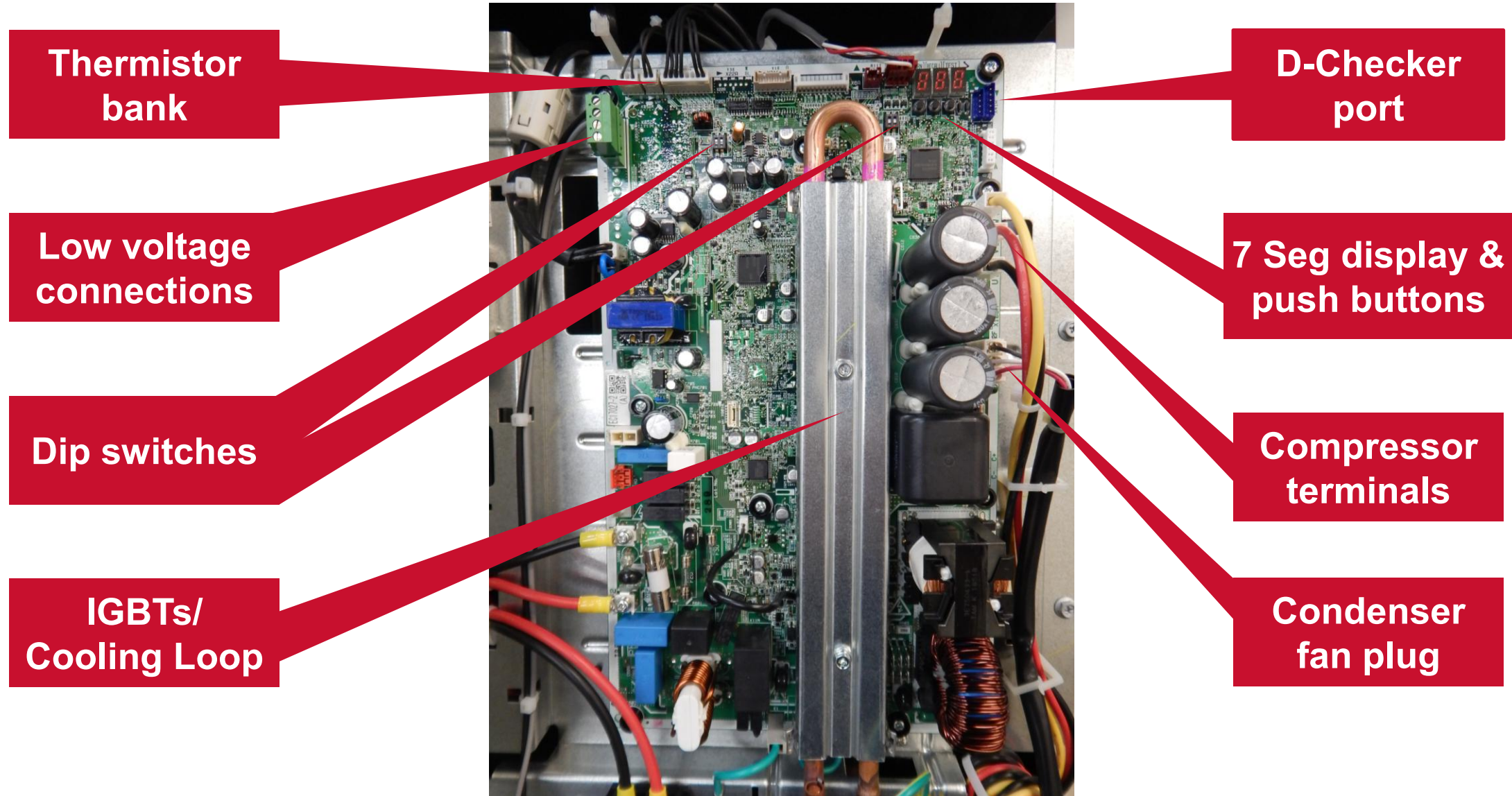

Electronic Expansion Valve

39

37

- Allows precision metering by responding instantly and continuously.
- Sensors input demand to open and close allowing the correct amount of refrigerant according to load requirement.
- EEV motor head can be replaced without recovering the refrigerant.
- Target superheat
 - Cooling: 9°F (5°C) - IDU EEV
 - Heating: 7°F (4°C) - ODU EEV

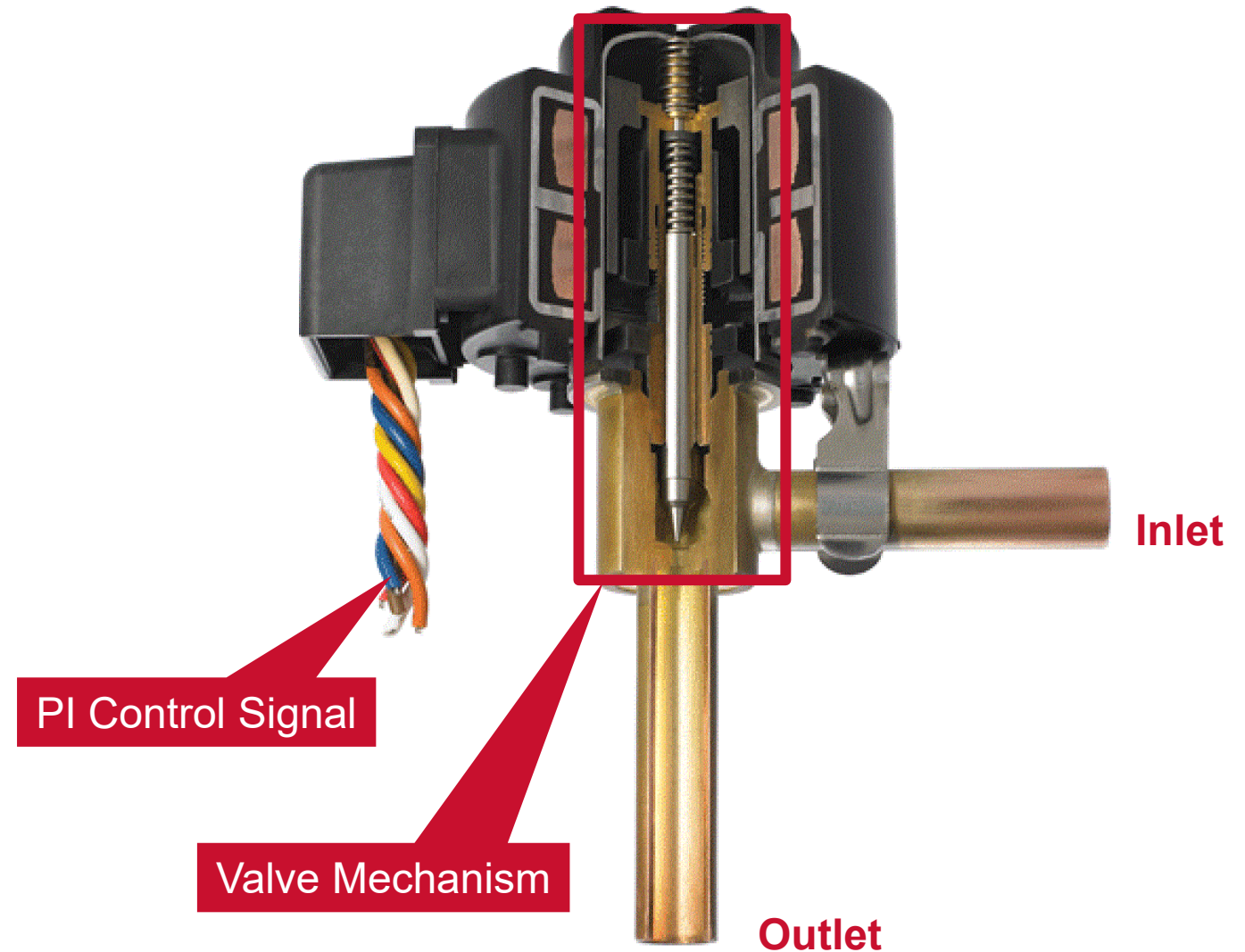



Agenda

Product and Accessories

Inverter Technology

Indoor Units

Nomenclature

A	H	V	E	2	4	B	P	1	4	0	0	A	A
1	2	3	4	5	6	7	8	9	#	#	#	#	#

Product

A – Corporate Air Handler
D – Daikin Air Handler

Application

C - Ceiling Mounted
M - Multi-Positional
W - Wall Mounted
H - Horizontal Discharge Compatible
Multi-Positional

Motor

S – MS-ECM
V – VS_ECM Communicating

Expansion Device

E – Electronic Expansion Valve
F – Flowrator
T – Thermal Expansion Valve

Nominal Capacity Range

12 - 1.0 Ton	36 - 3.0 Tons
18 - 1.5 Tons	42 - 3.5 Tons
24 - 2.0 Tons	48 - 4.0 Tons
30 - 2.5 Tons	60 - 5.0 Tons

Minor Rev

A – Initial release

Major Rev

A – Initial release

Electric Heat kW

Refrigerant

4 – R410A
6 – R410A or R22

Electrical

1 – 208/230 V, 1 Phase, 60 Hz

Cabinet

N – Uncased
P – Painted
U - Unpainted

Cabinet Width

AC* Series	AH* & AM* Series	AW* Series
M – 43.25"	B – 17.5"	S – 20.2"
L – 49.25"	C – 21.0"	L – 24.0"
	D – 24.5"	



AHVE

- Works with ASXS6 and ASZS6.
- High/low pressure transducer.
- Electronic Expansion Valve (EEV) for cooling and heat pump applications.
- Variable-speed ECM blower.
- Compatible with the communicating Amana Smart Thermostat.
- Provides constant CFM over a wide range of static pressure conditions.
- Horizontal or vertical configuration.
- 7mm coil tubing



MBVC

- Variable-speed ECM blower.
- Compatible with Amana Smart Thermostat.
- Advanced configuration of the airflow and tonnage in communicating mode.
- Provides constant CFM over a wide range of static pressure conditions independent of duct system.
- CFM indicator.
- Fault recall of six most recent faults.
- Blower section usable as electric heater.
- Horizontal or vertical configuration capabilities.



Cased Coils

Indoor coil options

- CAPEA (1.5-3 ton) Coil with Control Module
- CAPE (3.5-5 ton) Coil with Control Module (ASXS6 only)
- CHPE Coil with Control Module (ASXS6 only)



Furnaces

Compatible with Amana 80%, 96%, or 97% AFUE communicating furnace



Installation & Commissioning

Amana S-Series Installation and Commissioning
Technical Training Module TRV-6.2



Rest assured.
It's an Amana® brand.



© 2022 Daikin Comfort Technologies North America, Inc.
Amana® is a registered trademark of Maytag Corporation or its related companies and is used under license.
All rights reserved.



Agenda

Pre-Installation

Installation

Commissioning

ODU Location Considerations

- Always follow the instruction manual for equipment clearances.
 - Improper ODU placement can cause adverse operation of the equipment. (i.e., short cycling, defrost, etc.)
 - Do not stack more than two units. (20" vertical clearance between the ODUs)
 - Sound vibration transmission should be considered when installing the unit.
 - Ensure that the roof structure can support the weight of the unit.
 - Refer to specification sheets for ODU weight.
- Proper consideration should be given to the weather-tight integrity of the roof.



Inclement Weather Considerations

- When operating the air conditioner in a low outdoor ambient temperature, be sure to follow the instructions described in the install manual.
 - Install the unit so that the bottom of the frame is 20 inches higher than the expected snow fall.
- Considering wind exposure:
 - Install the outdoor unit with its suction side facing the wall.
 - Install a baffle plate on the air discharge side of the outdoor unit.
 - Never install the outdoor unit at a site where the suction side may be exposed directly to wind.

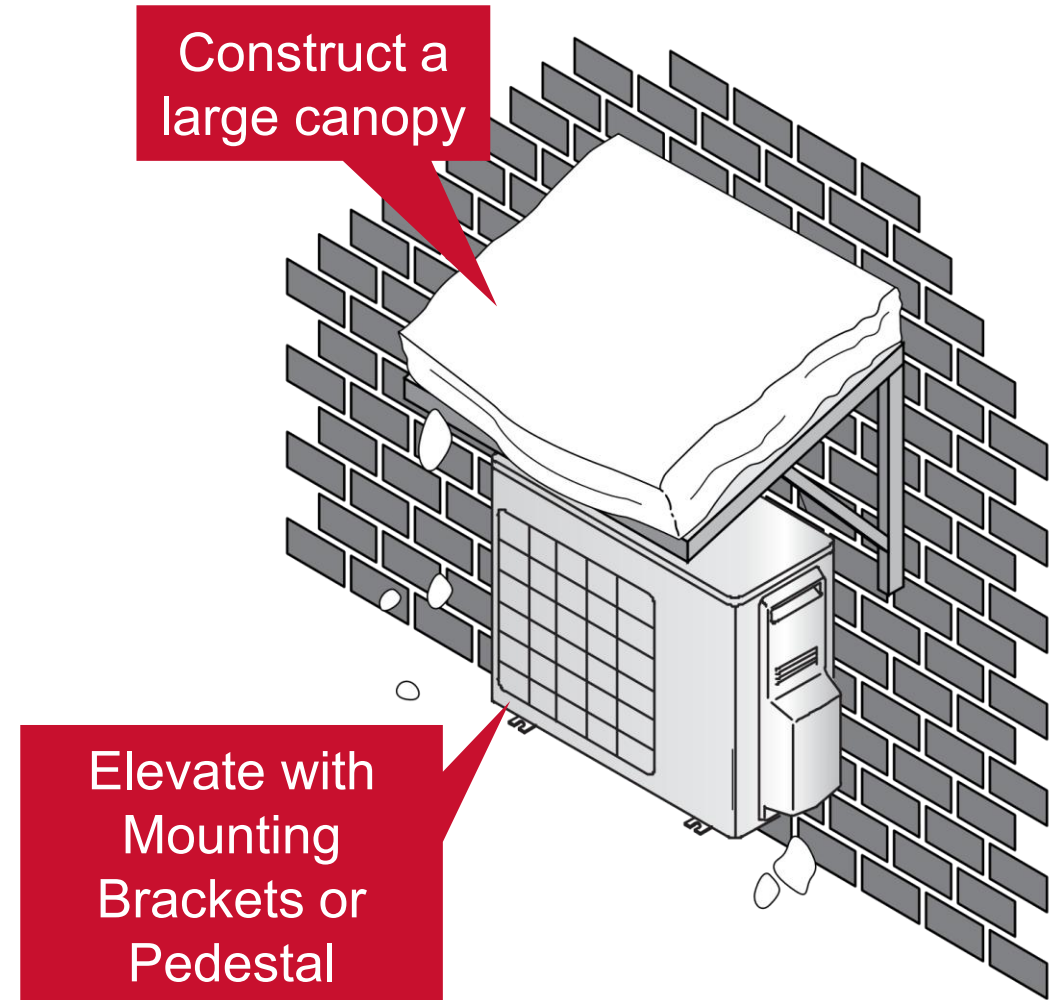



- The inverter units should be well grounded so that potential effects of electrical noise from the inverter to surrounding equipment is minimal.
- When selecting an install location, keep enough distance (at least 60") from home stereos, personal computers, etc.

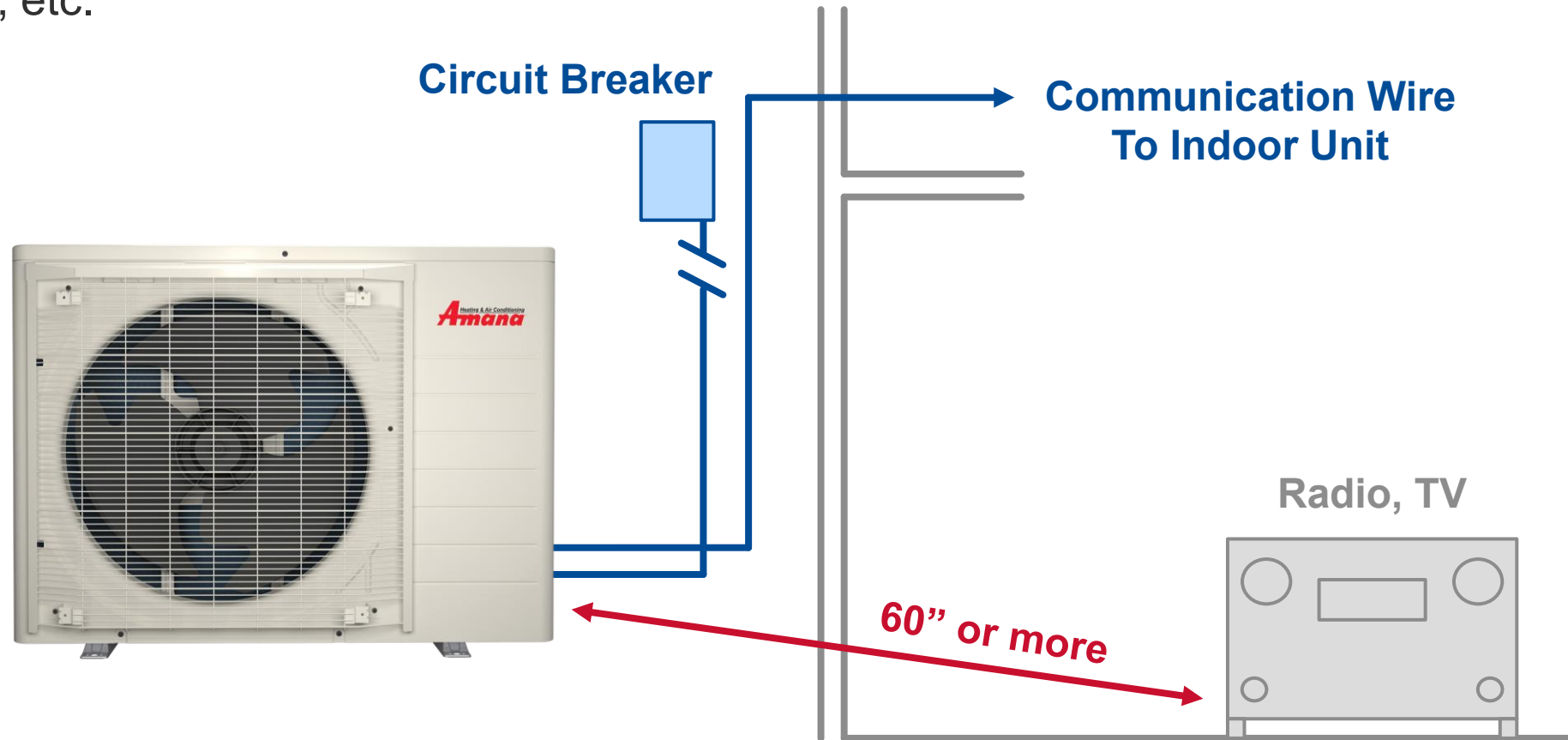

Agenda

Pre-Installation

Installation

Commissioning

Piping Diagram

ASZS6 HP 3.5–5.0-Ton

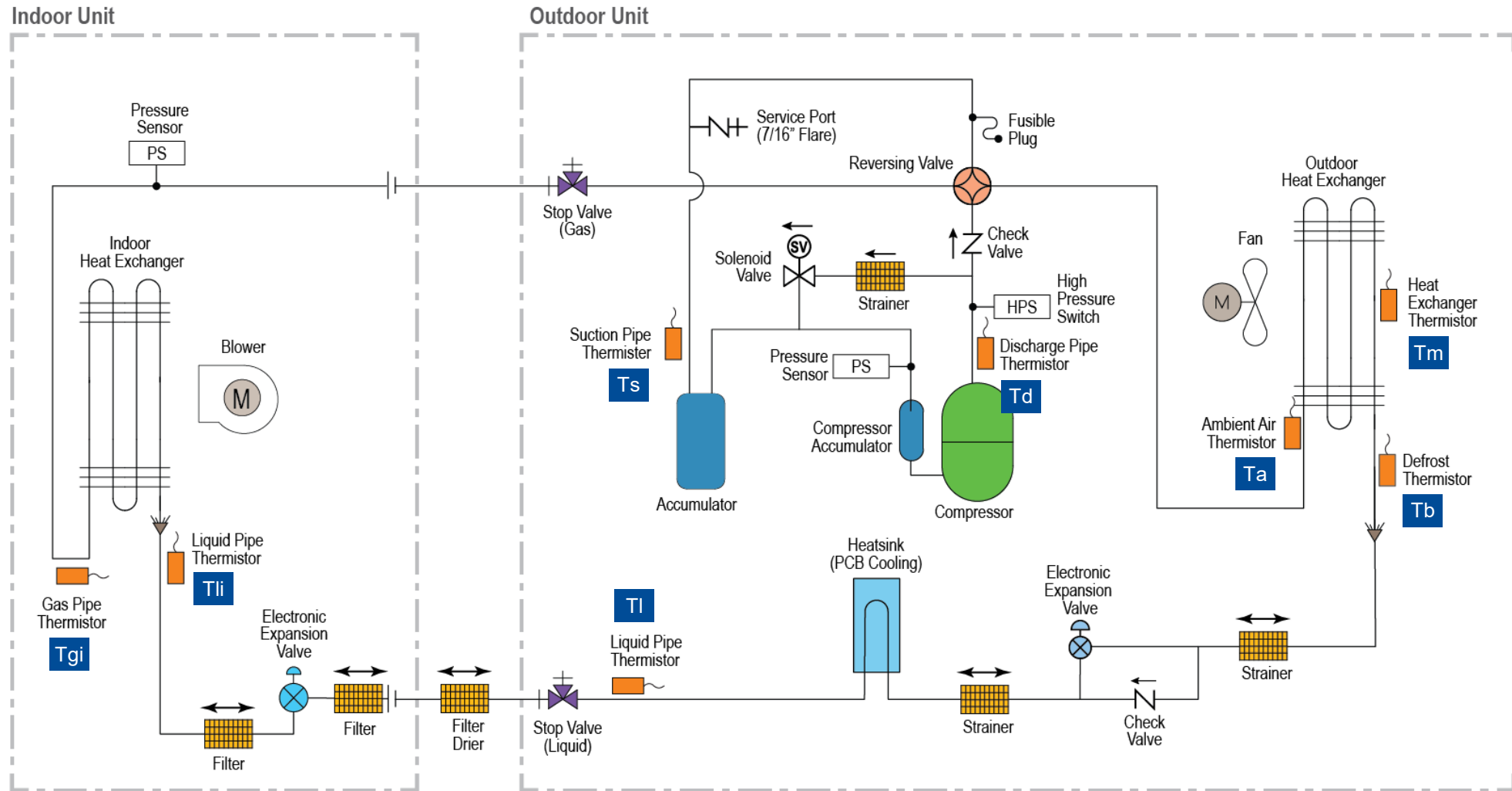

Refer to the service manual for piping diagrams

Refrigerant Piping



Amana S-Series outdoor unit above indoor unit

- An inverted refrigerant trap is not required when the outdoor unit is above the indoor unit.
- Max. line set equivalent length of 125 ft.
 - Includes pressure losses of any elbows, bends etc.

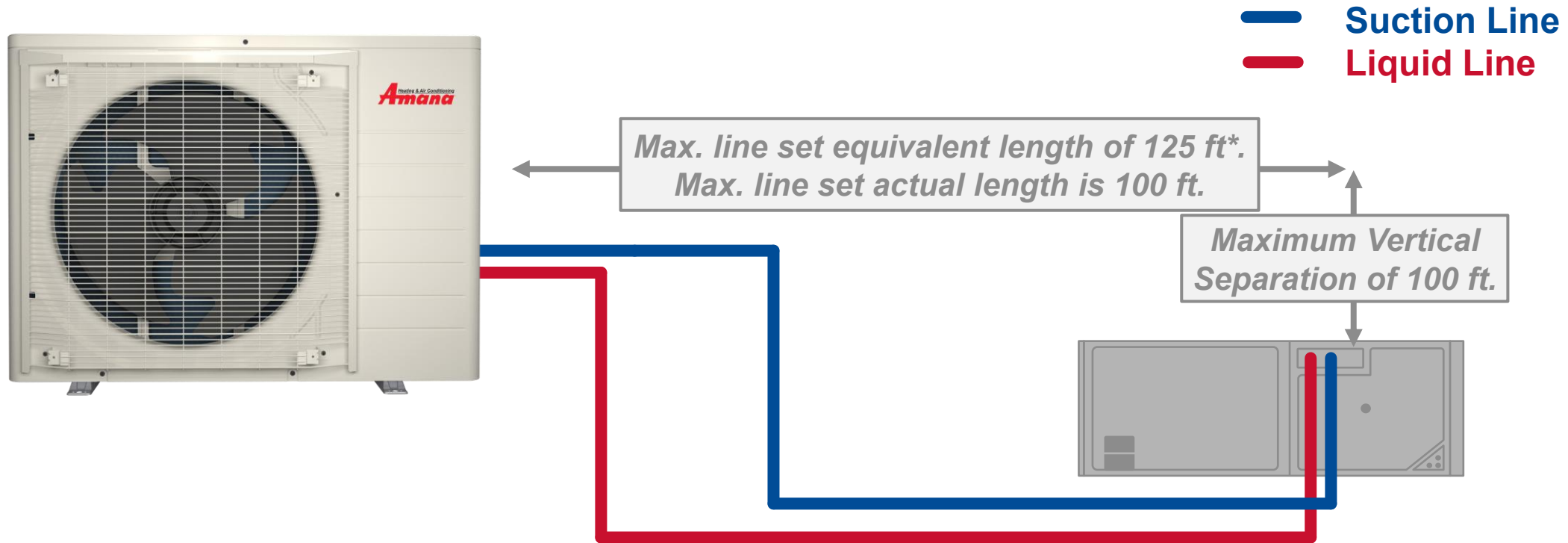

Refrigerant Piping

Amana S-Series outdoor unit below indoor unit

- Requires an inverted loop in the suction line near the connection to the indoor coil. (prevents liquid migration to the outdoor unit from the indoor unit)
- The top of the loop must be slightly higher than the top of the coil.
- Max. line set equivalent length of 125 ft.
 - Includes pressure losses of any elbows, bends, etc.

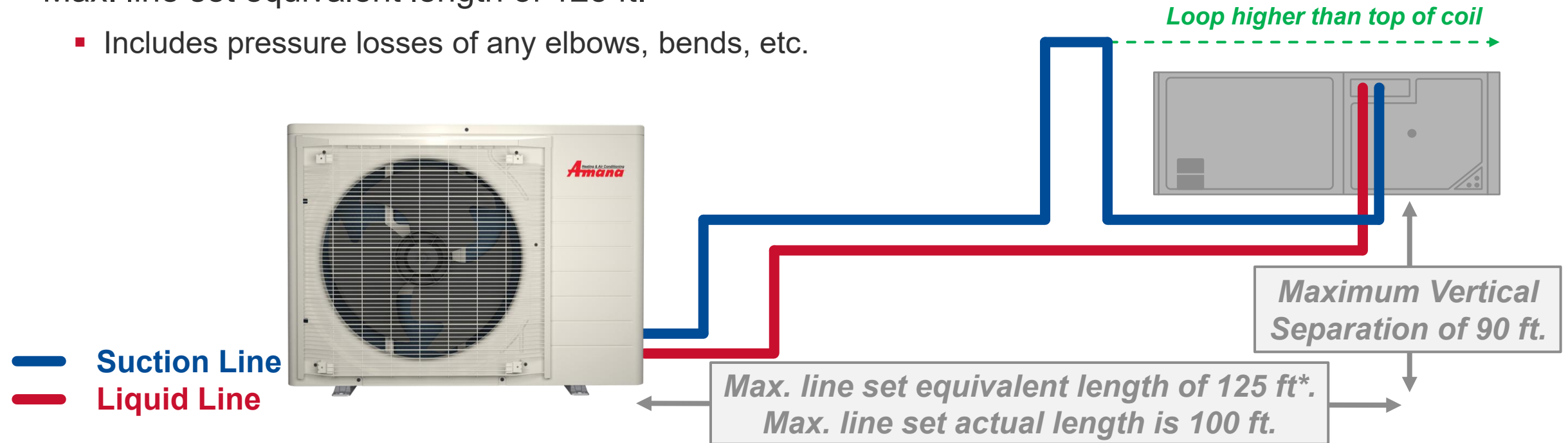

Existing Refrigerant Lines

- Drain as much residual compressor oil from existing line sets, and traps.
 - Pay close attention to low areas where oil may collect.
- If changing refrigerant or using existing refrigerant lines, you **MUST** flush the existing refrigerant lines.
- Use a professional flushing agent to remove any excess oil or debris from the prior HVAC system.

NOTE: Legacy oil drainage and passive nitrogen flush recommended.



Preparation for brazing

- REMOVE Schrader cores from service valves before brazing tubes to the valves.
- Use a brazing alloy of 2% minimum silver content, (15% preferred) and DO NOT use flux.
- Wrap valves with a wet rag or heat gel to prevent damage to valve.
- If filter drier paint is scratched or burned, corrosion may occur.

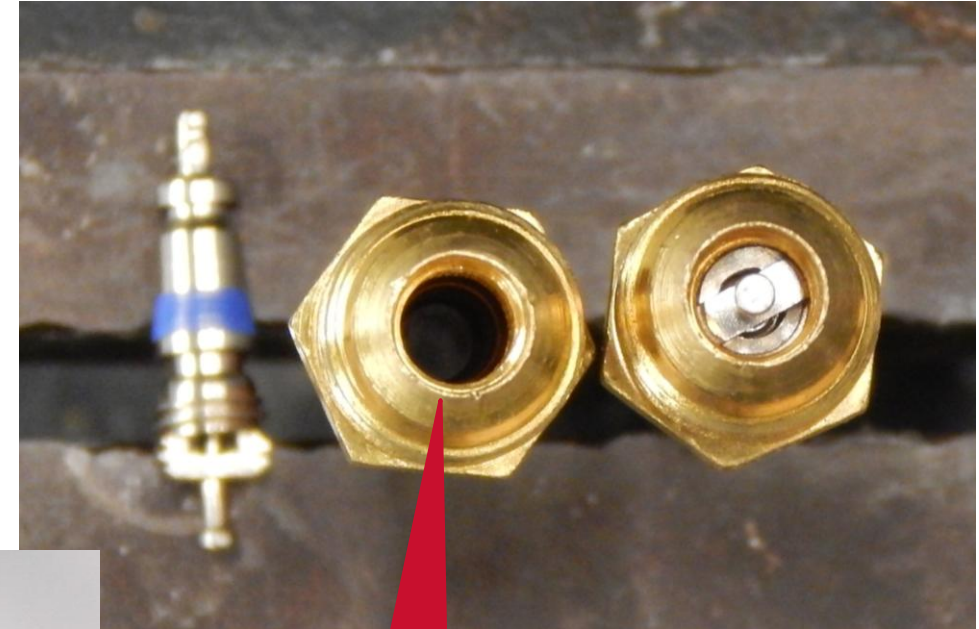

Removed
Schrader
Core

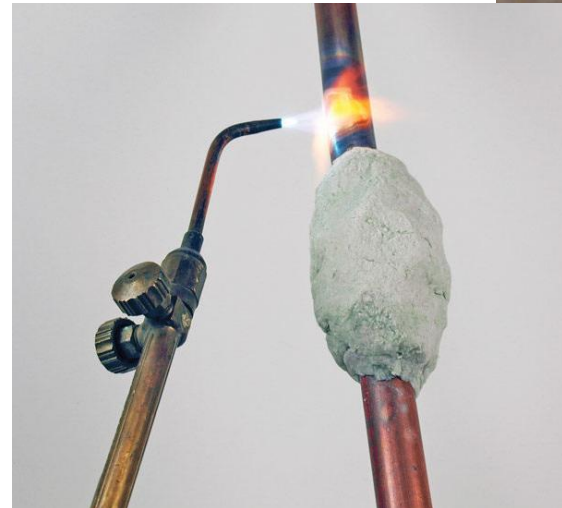

Brazing

Brazing with nitrogen

- Dry nitrogen must be used during brazing to prevent oxidation formation.

Step 1: Leave opposite end of tubing open, so that nitrogen can exit during brazing.

Step 2: Set nitrogen regulator to 20 psig. to purge the line set for 15-30 seconds.

Step 3: Set nitrogen regulator between 1.5 to 3.0 psig. and sweep refrigerant lines while brazing.

Step 4: After brazing, quench the joints with water or a wet cloth to prevent overheating of the service valve and filter drier.



High Voltage Wiring

- The unit rating plate lists pertinent electrical data necessary for proper electrical service and overcurrent protection.
- Wires should be sized to limit the voltage drop to 2% max. from the main breaker.
- Local codes often require a disconnect switch located near the unit.
- DO NOT install the switch on the unit.

NOTE: 3.5-5-ton has an optional knockout to route the high voltage wiring.



DAIKIN COMFORT TECHNOLOGIES MANUFACTURING, INC.
 19001 KERMIER RD, WALLER, TX 77484
 AIR CONDITIONER (OUTDOOR SECTION)
 MODEL ASXS6S3610AA
 SERIAL NUMBER 9999999999
 MFG. DATE 2022.8
 NET WEIGHT 133 lbs 60.5 kg
 POWER SUPPLY 1-208/230V 60HZ



MAX OVERCURRENT PROTECTIVE DEVICE	25 A	MAXIMUM ALLOWABLE PRESSURE	604 psig 4.17 MPa
MINIMUM CIRCUIT AMPACITY	23.9 A	AIR TIGHT TEST PRESSURE	604 psig 4.17 MPa
	FLA 2.00 A	REFRIGERANT R410A (FACTORY CHARGED)	85 oz 2.40 kg
FAN MOTOR	OUTPUT 0.20 HP 0.15 kW	PROTECTION	IPX4
COMPRESSOR	RLA 16.8 A		
MOTOR	LRA A		

** INVERTER/CONTROLLER LIMITED TO LESS THAN 1 AMP SCCR kA RMS.
 SYMMETRICAL @600V MAX:5



CONFORMS TO ANSI/UL
 STD. 80335-1 & 80335-2-40D
 CERTIFIED TO CSA STD.
 C22.2 NO. 80335-1 &
 80335-2-4D



ELECTRICAL CHARACTERISTICS ARE ONLY FOR OUTDOOR UNIT
 SUITABLE FOR OUTDOOR USE
 INSTALL PROHIBITED IN U.S. SOUTHWEST
 ASSEMBLED IN THE USA

Intertek
 5004994
 2P697228-4

High Voltage Wiring

Minimum circuit ampacity maximum overcurrent protection charts in I/O

- When using residual current operated circuit breakers, be sure to use a high-speed type (0.1 seconds or less) 200mA rated residual operating current.
- Use copper conductors only, and insulated power wiring.
- Select the power supply cable type and size in accordance with local codes.

Model	Phase and frequency	Voltage	MCA (min. circuit amp.)	MOP (Max. overcurrent protective device)	Transmission line selection
1.5 ton (18)	1 Phase 60Hz	208/230	14.6 A	15 A	18 AWG (typical)
2 ton (24)			18.8 A	20 A	
2.5 ton (30)			23.9 A	25 A	
3 ton (36)			23.9 A	25 A	
3.5 ton (42)			34.4 A	35 A	
4 ton (48)			34.4 A	35 A	
5 ton (60)			36.2 A	40 A	

High Voltage Wiring

- Route power supply and ground wires through the high voltage port and terminate in accordance with the wiring diagram.
- Connect 208/230V/60Hz field wiring to the terminal block located in electrical panel.

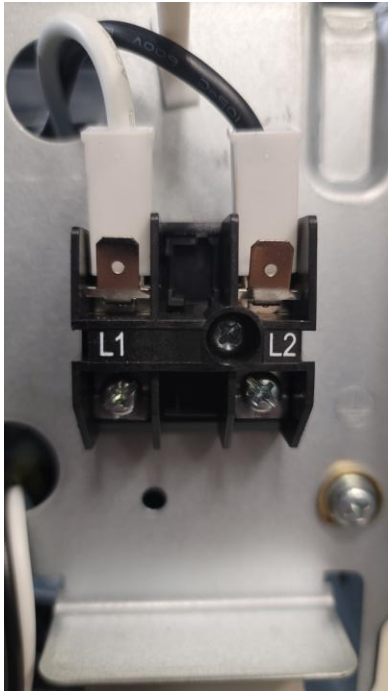

**Terminal Block
1.5 - 3.0 Ton Units**

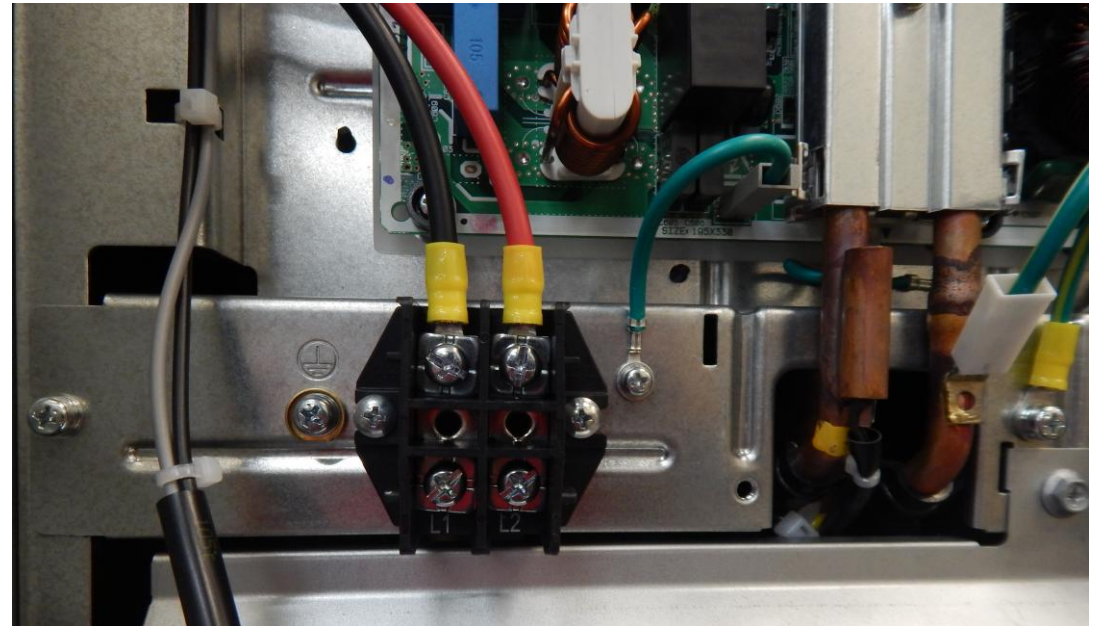

**Terminal Block
3.5 - 5.0 Ton Units**

Low Voltage Wiring

Communicating wiring detail

- If low voltage requirements are not met:
 - Check/eliminate wiring connections
 - Crossed wires, loose bent, broken wires, etc.
 - Replace wiring
 - 18 AWG stranded is recommended

Amana Smart Thermostat

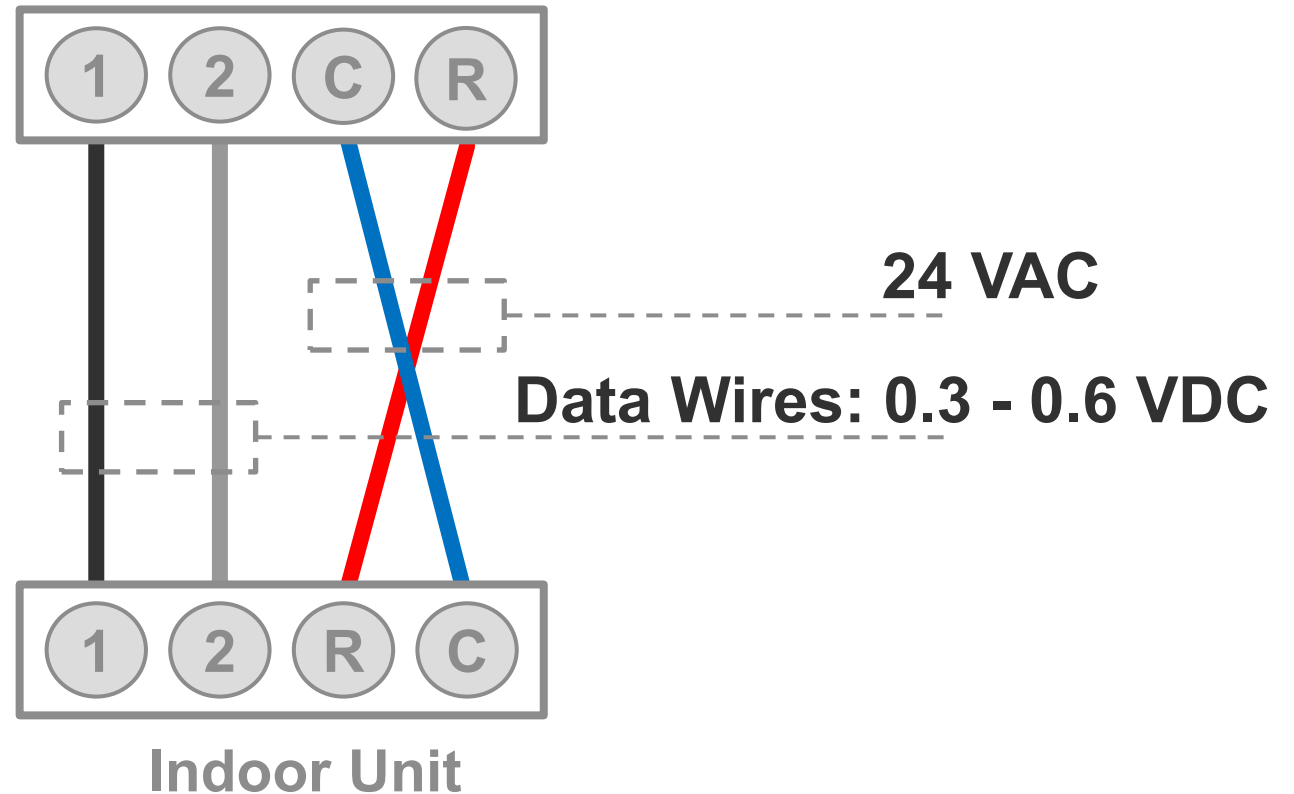

Low Voltage Wiring



Wiring detail for the Amana S-Series paired with an air handler

- Minimum 18 AWG.
- Max 125' between communicating thermostat and indoor units.
- Max 250' between outdoor and indoor units.
- Four wires from indoor unit and coil PCB to thermostat.
- Two wires to outdoor unit.

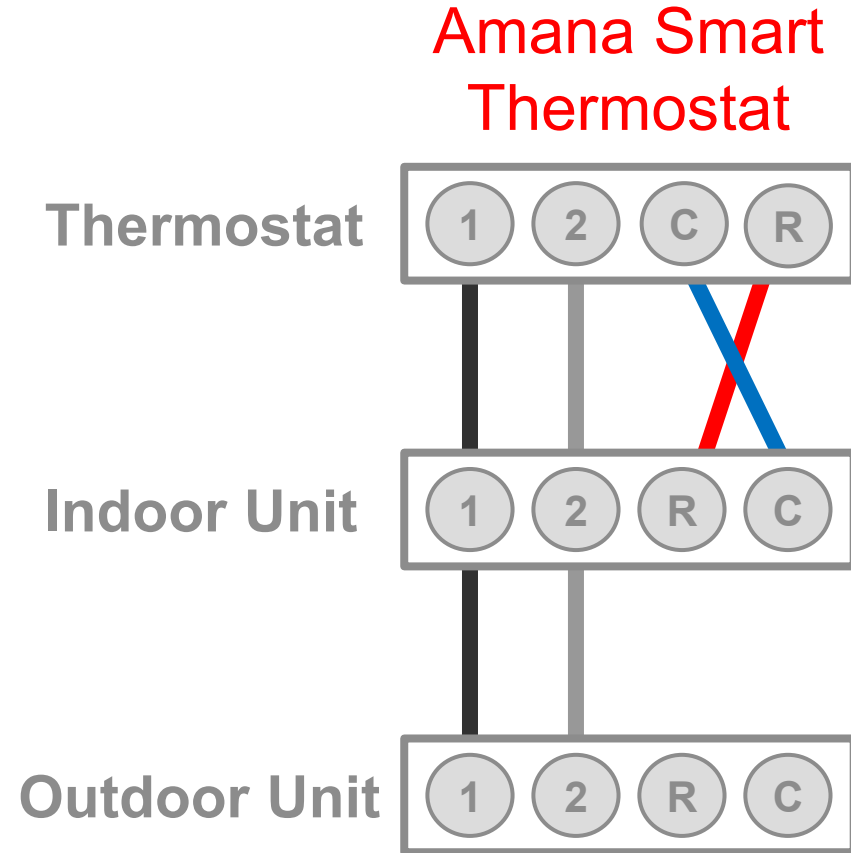

Low Voltage Wiring

Wiring detail for the Amana S-Series system paired with a gas furnace/MBVC and cased coil

- **Data line 1**
- **Date line 2**
- **R (24 VAC hot)**
- **C (24 VAC common)**

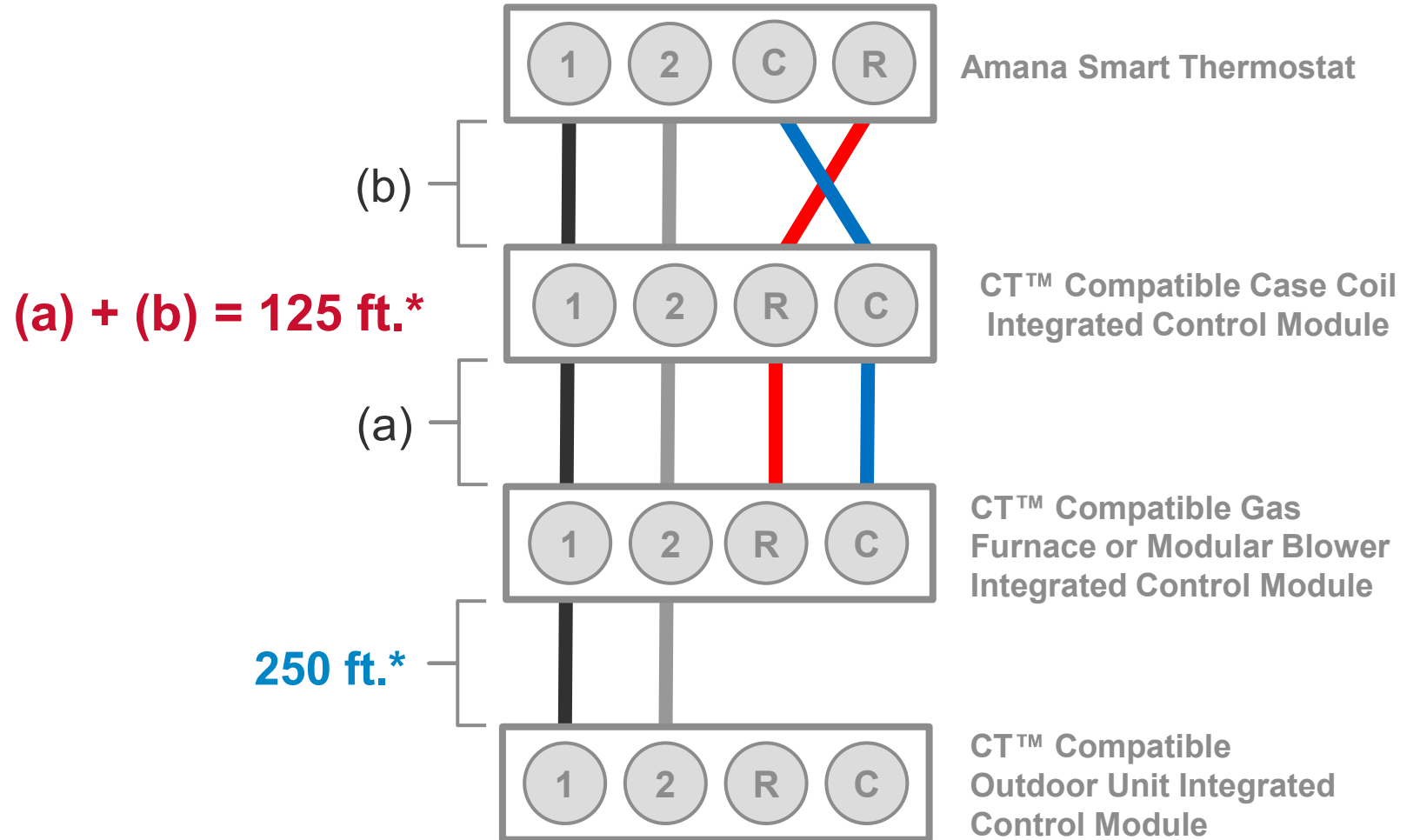

* Maximum allowable length

Communicating Thermostats In All Zones

UT-3000 Zone Control System

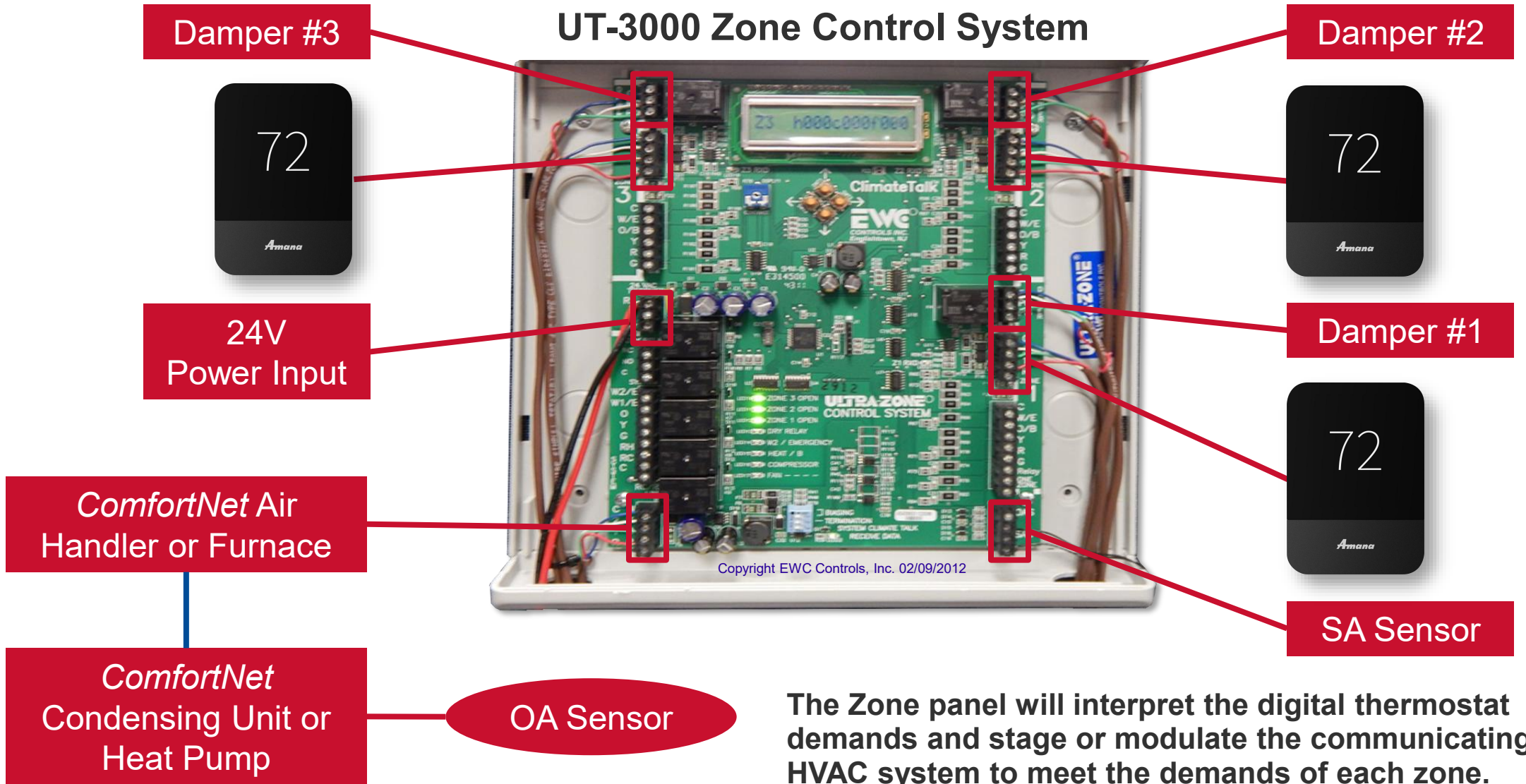

The Zone panel will interpret the digital thermostat demands and stage or modulate the communicating HVAC system to meet the demands of each zone.

Triple Evacuation Tools

Vacuum rated hoses



- Vacuum rated hoses must be used to ensure a proper system evacuation.
 - Larger diameter
 - Shorter length

Evacuation pump



- Having a properly maintained vacuum pump is important for evacuating a refrigerant system.
- Pump capacity minimum of 2 cfm two stage.
- Check valve in vacuum pump.

Micron gauge



- Vacuum gauge w/digital display
- Using a micron gauge for the entire evacuation process is mandatory on all Amana systems

Vacuum rated core removal tool



- Removing the core increases the diameter of the valve access port, reducing the amount of time needed to evacuate.
- Reduced leak points compared to the manifold.

System Evacuation

- Some pumps come with 3/8- or 1/2-inch hose connections on the pump.
- By connecting larger vacuum rated hoses and removing the Schrader cores, evacuation will be faster and more complete.
- Attach a micron gauge to the port on the core remover.
- With this connection, there is no need for a manifold. (less chance for leaks)

REMOVE Schrader cores from service valves before brazing tubes to the valves

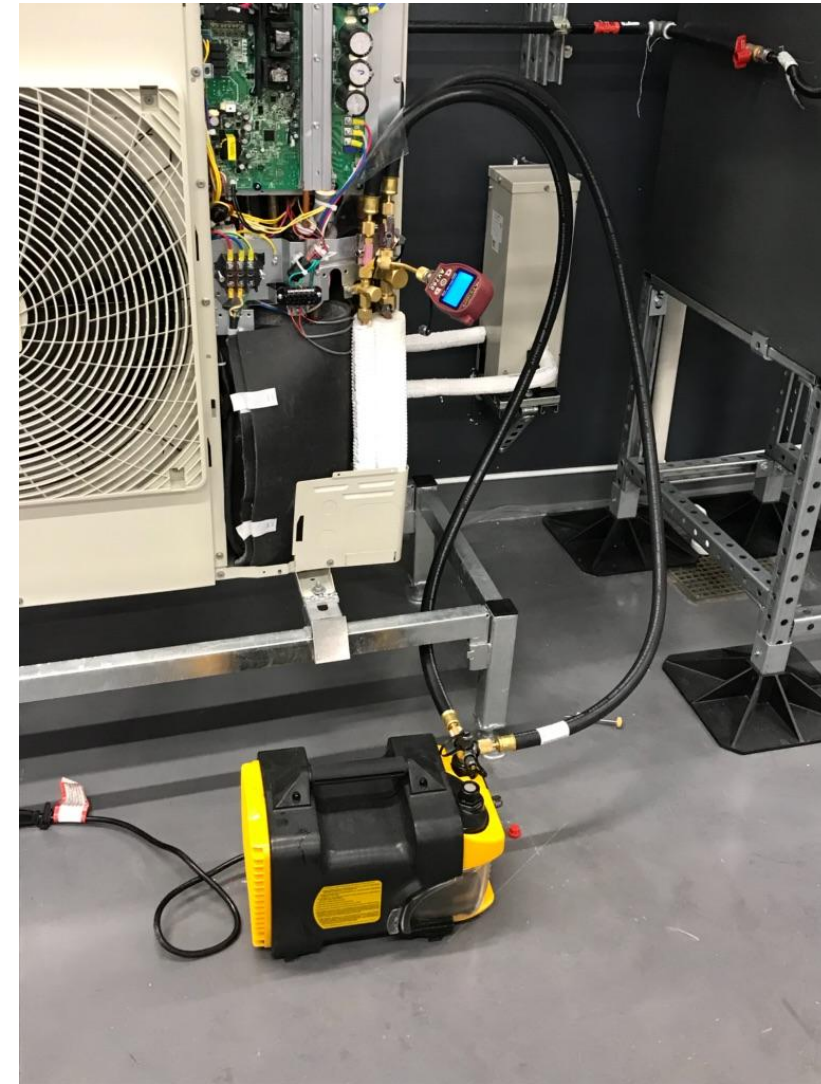



Calculate refrigerant charge based on line set length

- The outdoor unit is shipped with a predetermined factory charge level as shown in the *S-Series* I/O.
- The installer **MUST** measure the new or existing line set length and diameter for the best charging calculation.
- Charging tables are provided in the *S-Series* I/O based on indoor coil and line set length and diameter.
- For 1.5-ton only: ¼-inch liquid line is acceptable.

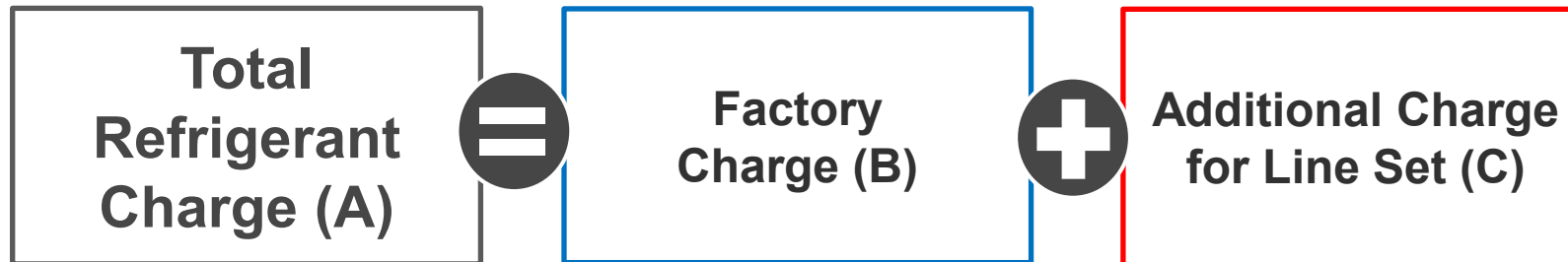

NOTE: Beyond your calculated charge, not more than 0.5lb. (8 oz.) of refrigerant must be added to the system to achieve the target sub-cooling. It is recommended to add 1 oz. refrigerant each time and let the system stabilize for 10 minutes.

Charging the Amana S-Series System

Charging example 1:

- 2-Ton AC with CAPEA Coil
- 30 feet of line set
 - 3/8-inch liquid line
 - 3/4-inch suction line
 - $30 - 15 = 15$ additional feet line set to calculate
 - $15 \times 0.6 = 9$
 - **Add 9 ounces of R-410A refrigerant**

Charging example 2:

- 2-Ton AC with CHPE Coil
- 45 feet of line set
 - 3/8-inch liquid line
 - 3/4-inch suction line
 - $45 - 12 = 33$ additional feet line set to calculate
 - $33 \times 0.6 = 19.8$ (round up to 20)
 - **Add 20 ounces of R-410A refrigerant**

Agenda

Pre-Installation

Installation

Commissioning



Start-up

- Tapping begin set-up starts the five step set-up process:
 - Communication.
 - Personalization.
 - Equipment Set-up.
 - System Optimization.
 - Preferences.

Note: All steps must be completed and reviewed before completing set-up to ensure the system is configured properly and ready for the homeowner to use.

For detailed menu settings

<https://amana-hac.com/resources>

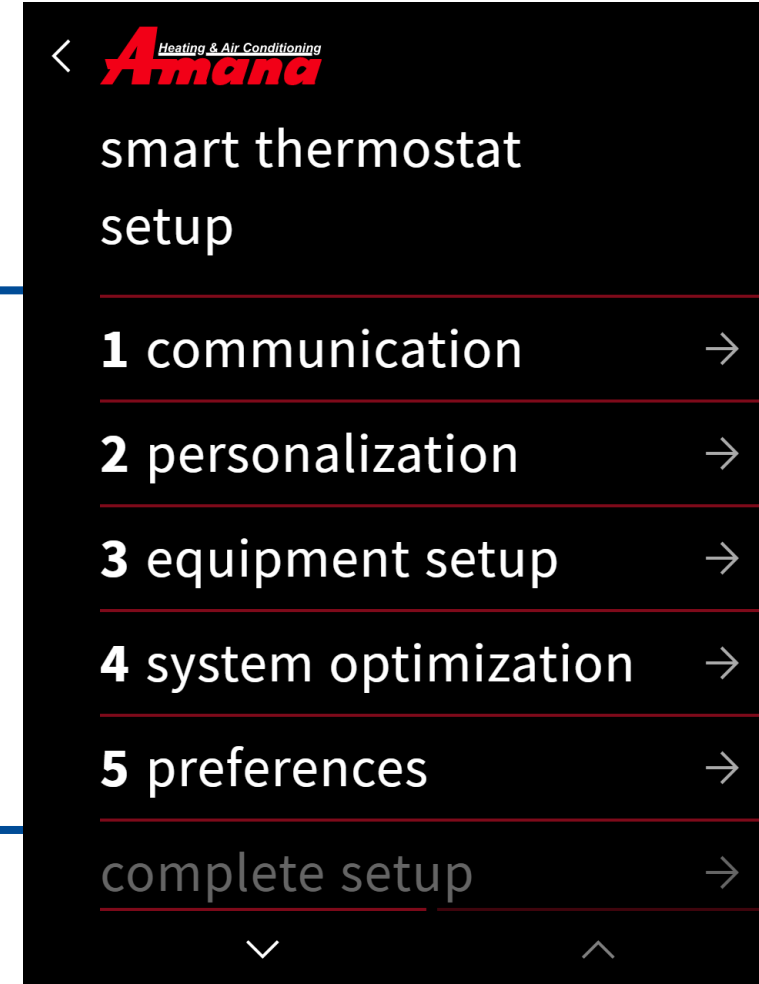

Full Set-up

Step 3 - Equipment Set-up

- Displays equipment found by searching the communication network, or by adding/removing equipment and accessories from the preset list.
- The unit that is identified determines the list of configurations that will be displayed
 - View unit Specifications.
 - Configure
 - Cool settings
 - Heat Settings
 - Heat Pump Settings
 - Aux alarm
 - Heater Kit

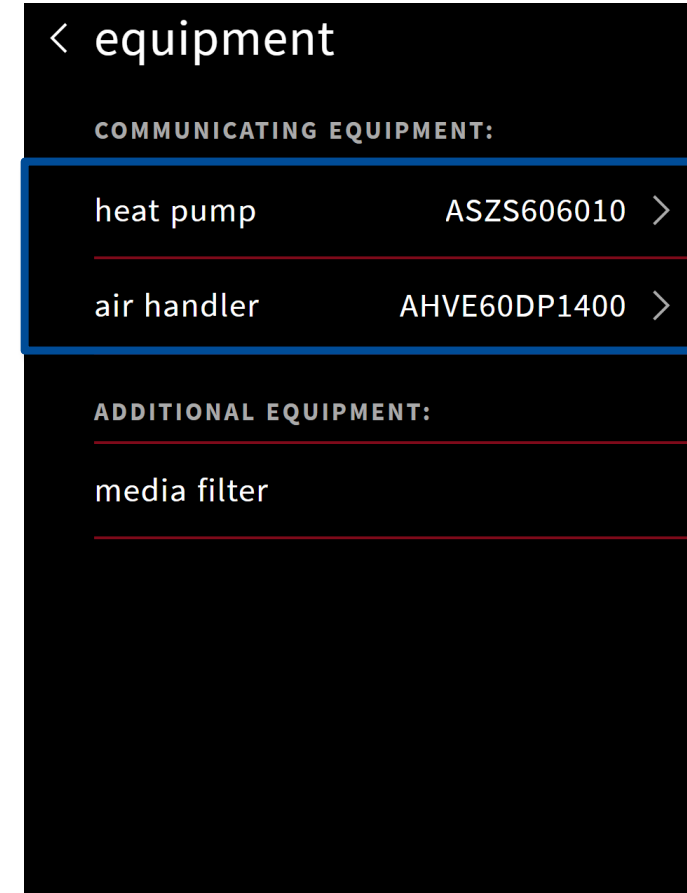
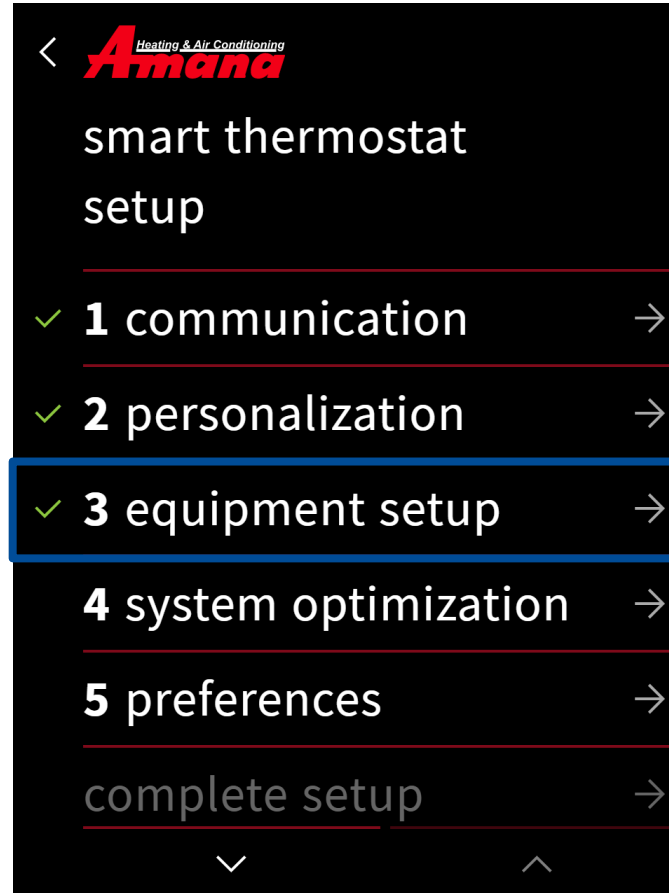

Dehumidification

- Selecting the equipment's cool settings allows you to verify that you have the correct dehumidification profile selected.

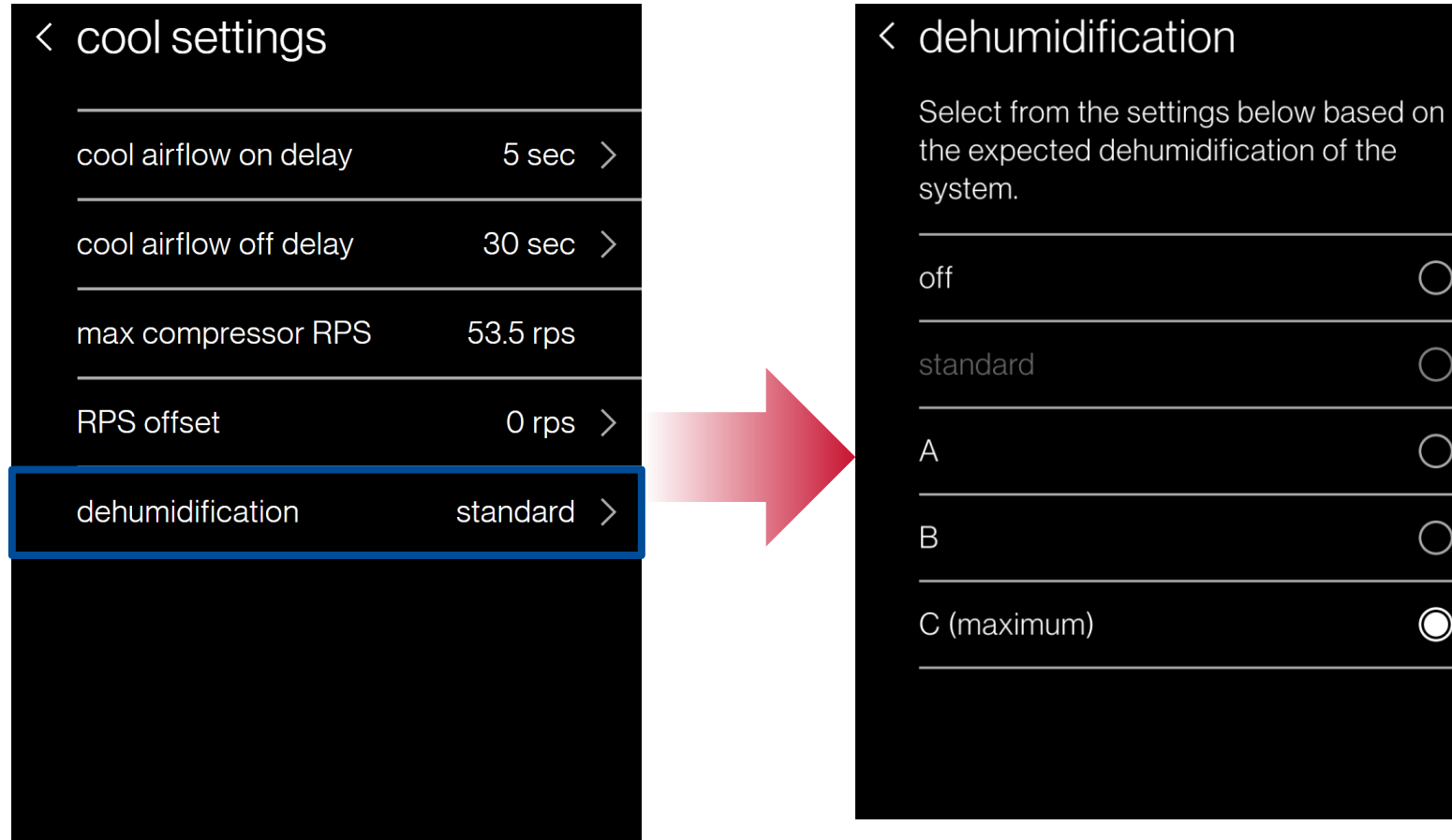

Cool Airflow Profiles



- Refer to the installation manual.
- There are four (4) cooling airflow profiles available.
- All residential inverter systems are factory set for **Profile D**.



Profile A provides only an OFF delay of one (1) minute at 100% of the cooling demand airflow.

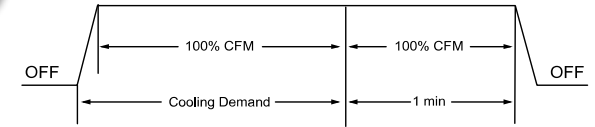

Profile B ramps up to full cooling demand airflow by first stepping up to 50% of the full demand for 30 seconds. The motor then ramps to 100% of the required airflow. A one (1) minute OFF delay at 100% of the cooling airflow.

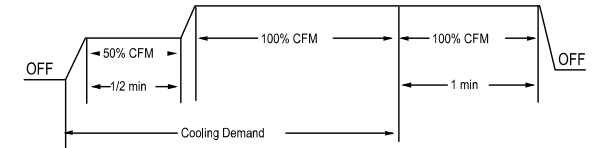

Profile C ramps up to 82% of the full cooling demand airflow and operates there for approximately 7 1/2 minutes. The motor then steps up to the full demand airflow. Profile C also has a one (1) minute 100% OFF delay.

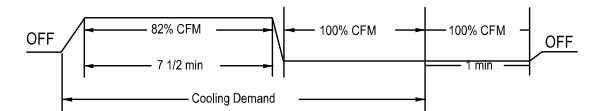

Profile D (default) ramps up to 50% of the demand for 1/2 minute, then ramps to 82% of the full cooling demand airflow and operates there for approximately 7 1/2 minutes. The motor then steps up to the full demand airflow. Profile D has a 1/2 minute at 50% airflow OFF delay.

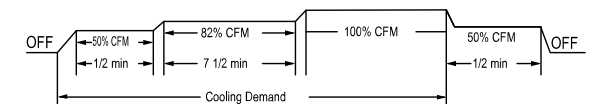

Profile D (default) ramps up to 50% of the demand for 1/2 minute, then ramps to 82% of the full cooling demand airflow and operates there for approximately 7 1/2 minutes. The motor then steps up to the full demand airflow. Profile D has a 1/2 minute at 50% airflow OFF delay.

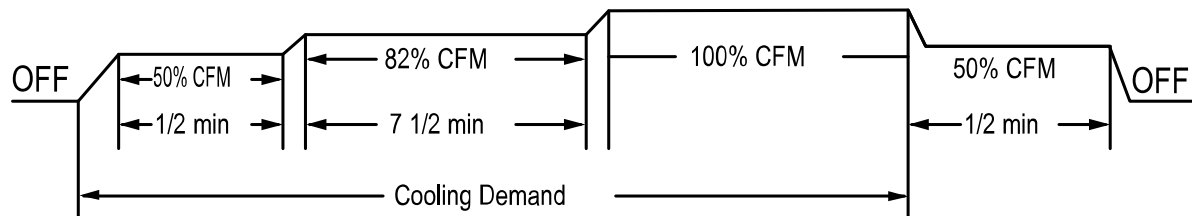

Defrost Operation

- Defrost interval every 30, 60, 90 or 120 minutes is selected from the thermostat menu.
- If defrost sensor drops below freezing temp. during the selected interval, ODU PCB initiates defrost cycle.
 - The ODU fan motor and compressor will de-energize.
 - The reversing valve switches from heating to cooling operation.
 - ODU PCB communicates to energize back up heat if enabled.
 - The coil and defrost sensor temperatures are monitored every 5 seconds.
 - When the coil temperature reaches 54°F and the defrost sensor temperature is greater than 43°F for 30 seconds, defrost operation is terminated.
- Backup defrost heat
 - You can select the outdoor temperature for backup heat to activate during defrost. (At or below 30°F- 65°F or ON/OFF).

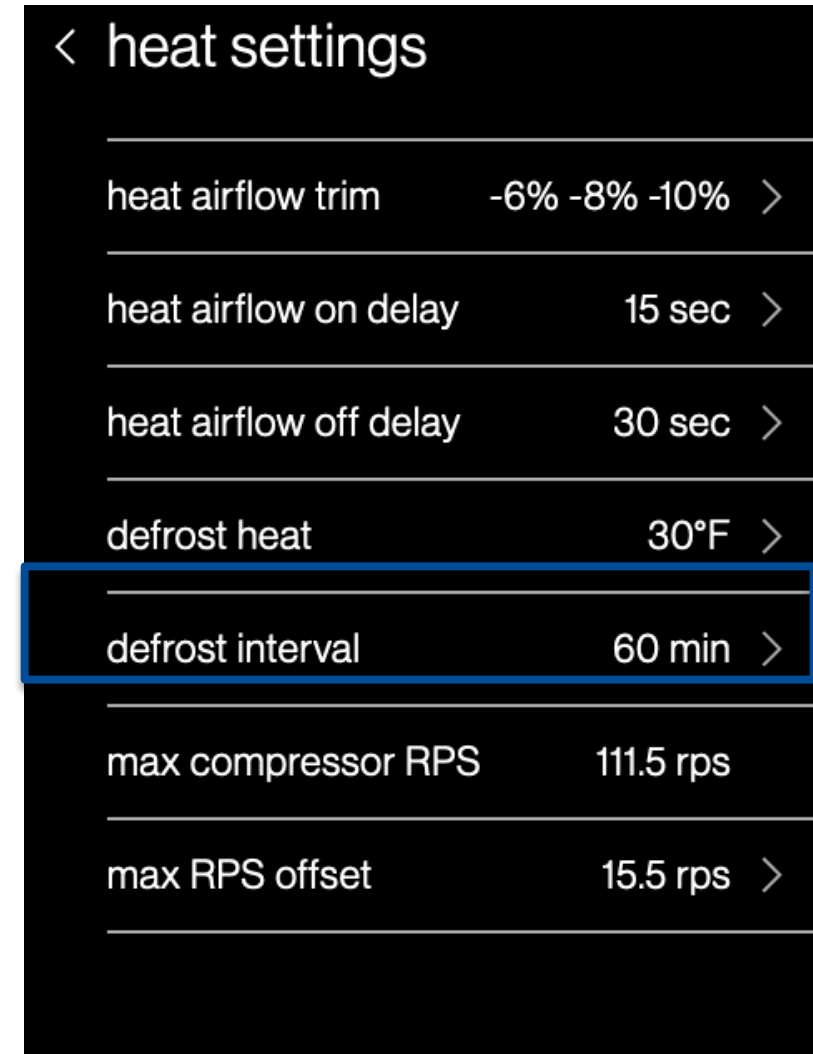

Defrost Operation

Intelligent defrost

- If it takes longer than 5 minutes to reach target coil temperature, then the initial time interval you selected will be shortened for entering the next defrost mode.
- If it takes less than 5 minutes during the defrost mode to reach the target coil temperature, then it will lengthen the interval before entering the next defrost mode.

Intelligent Defrost

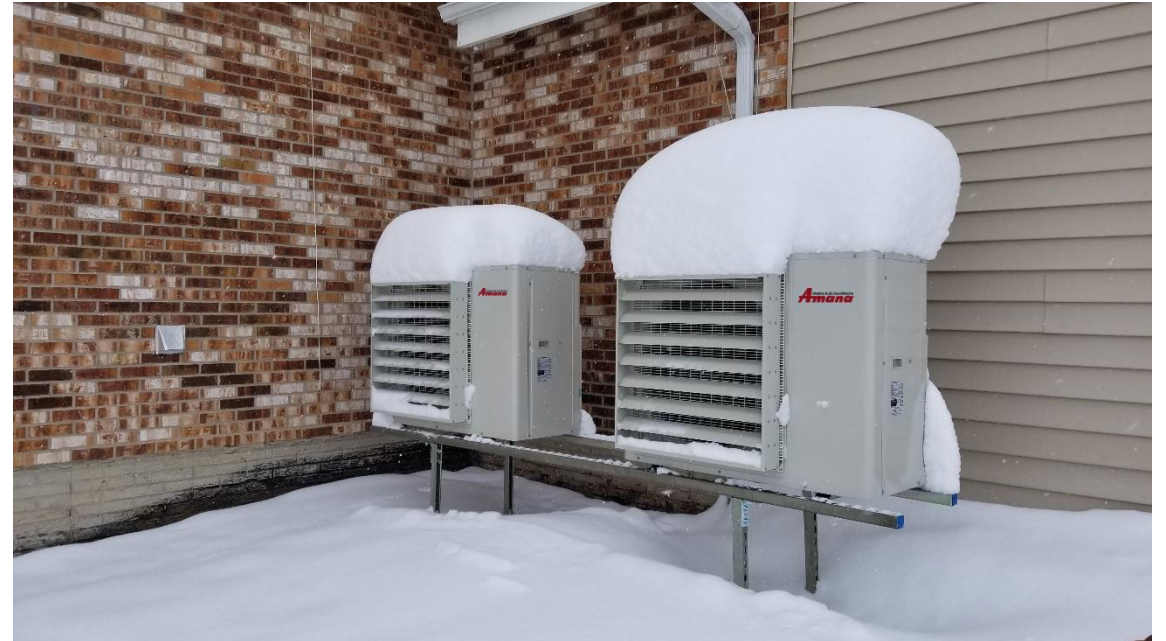

Secondary Heat

- On a dual fuel system, change over between heat pump and gas furnace is determined by the balance point temperature.
 - The heat pump will turn on above this lockout temperature.
 - Gas furnace will turn on below this lockout temperature.



Temp **greater than**
balance point

< balance point

45
50 °F
55

Aux (electric strip heat) and/or gas heat won't run above this outdoor temperature.



Temp **less than**
balance point



Full Set-up

Step 4 – System Optimization

- System optimization displays:
 - System test.
 - **Inverters only.**
 - Charge mode.
 - **Inverters only.**
 - Optional test.
 - Error history.
 - Logs alerts with an error code.
 - **White = not critical**
 - **Yellow = critical**
 - Calibration. Thermostat must be in OFF mode.
 - Wait 30 minutes before calibration for the thermostat to equalize.
 - Status.

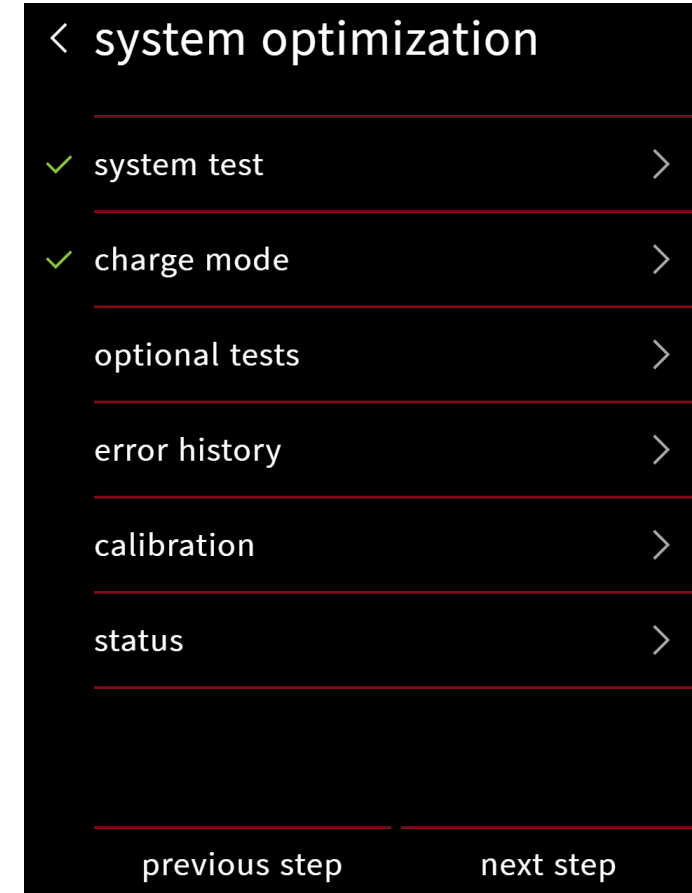
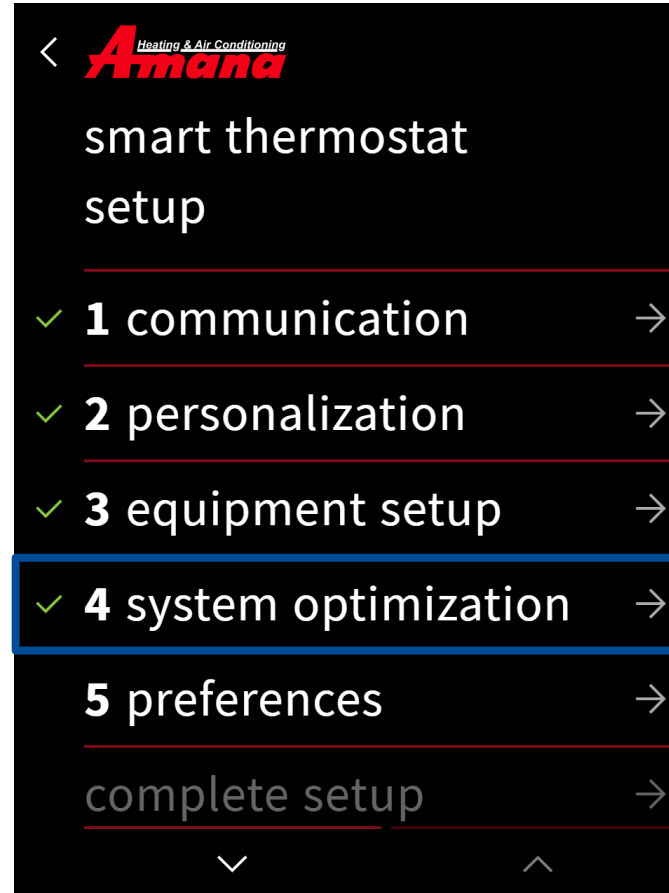

System test

- Running system test is required for the inverter units before proceeding to complete set-up.
 - You cannot stop this test.
- To proceed through the set-up process, the system test needs to be completed without any errors.
- When the tests are completed, the run test screen is displayed.
 - System test is complete only when display code E11 notice clears from the seven segment LED display on the heat pump or air conditioner.

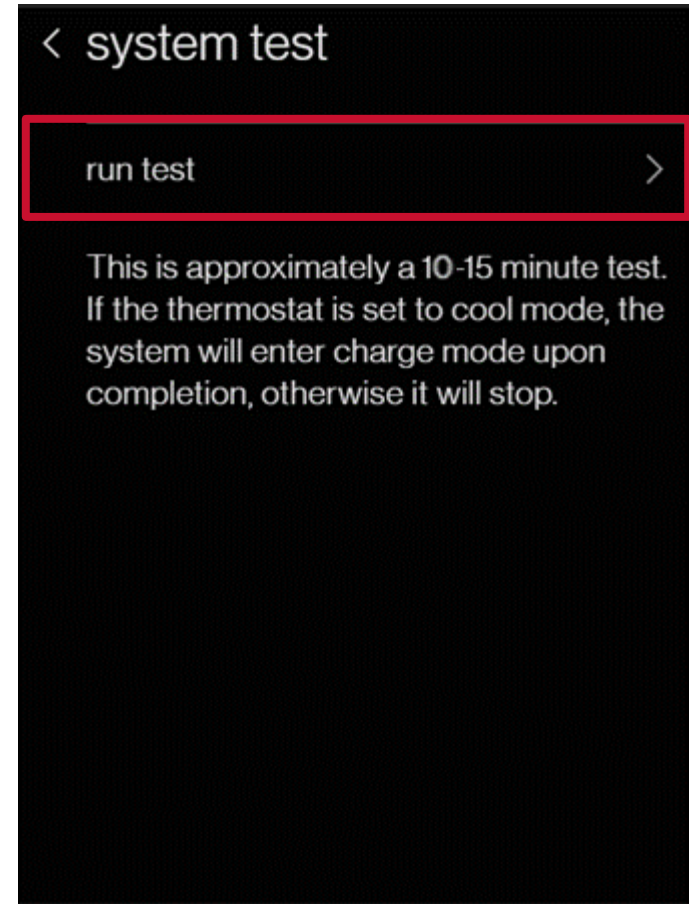
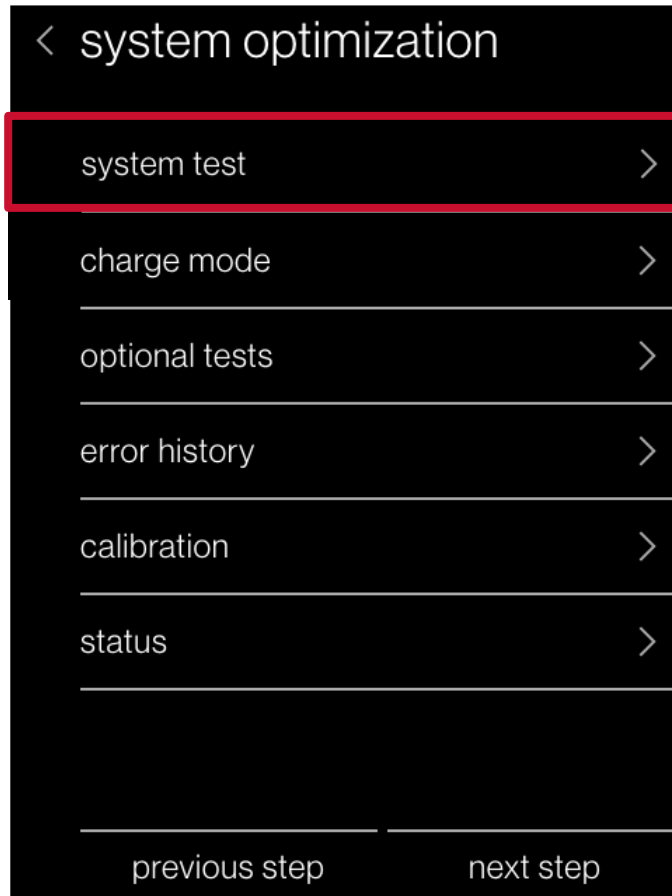

Checking Duct Static

- Refer to your rating plate for the maximum (ESP) external static pressure.
- Incorrect external static pressure may cause
 - Excessive temperature rise
 - Motor stress
 - Duct stress
 - Reduced performance
 - Unwanted condensation
 - etc.

FROM SEA LEVEL
DU NIVEAU DE LA MER

MODEL NO. AMVS800603BNAA
NO. DE MODELE
SERIAL NO. 1711465141
NO. DE SERIE

AHRI CERTIFIED
www.ahridirectory.org

POWER SUPPLY 115 VOLTS 1PHASE 60 HERTZ LESS THAN 12 AMPS.
CARACTERISTIQUES ELECTRONIQUES MOINS DE 12 AMPS.

	NATURAL GAS		L.P. GAS	
	HI	LO	HI	LO
HEATING INPUT (BTU/HR) DEBIT (BTU/HRE.)	60,000	42,000	60,000	42,000
OUTPUT CAPACITY (BTU/HR) PUISSANCE (BTU/HRE.)	48,000	33,600	48,000	33,600
FOR TEMPERATURE RISE OF (°F) ELEVATION DE TEMP. DE L'AIR	20 - 50		20 - 50	

DESIGN MAX. OUTLET TEMP. (°F) 150 LIMIT SET (°F) 140
TEMPERATURE MAX. DE L'AIR A LA SORTIE (°F) REGLAGE DE LIMITEUR (°F)

FACTORY TESTED EXTERNAL STATIC PRESSURE (IN. W.C.) .5
PRESSION STATIQUE VERIFIEE A L'USINE (PO. C. D'EAU)

MOTOR (H.P.) 3/4 BLOWER (IN.) 10X8
MOTEUR SOUFFLEUR (PO.)

AUX. LIMIT SETTING (°F) 120 NOx EMISSION LIMIT — ng/J

	NAT. GAS	L.P. GAS
MAXIMUM GAS SUPPLY PRESSURE TO FURNACE (IN.W.C.) PRESSION DU GAZ A L'ENTREE MAXIMUM (PO.C.D'EAU)	7	14
MINIMUM GAS SUPPLY PRESSURE FOR PURPOSE OF INPUT ADJUSTMENT (IN.W.C.) PRESSION DU GAZ A L'ENTREE POUR L'OBJET D'AJUSTAGE (PO.C.D'EAU)	5	11
MANIFOLD PRESSURE (IN.W.C.) PRESSION TUBULURE (PO.C.D'EAU)	3.5	10
MAIN BURNER ORIFICE SIZE INJECTEUR DE BRULEUR PRINCIPAL	45	55

ANSI Z21.47b/CSA2.3b 2006

GAS-FIRED GRAVITY & FORCED AIR CENTRAL FURNACES STANDARD
ACCEPTED FOR USE, CITY OF NEW YORK, MEA

ETL
LISTED US
Intertek
3073027

Checking Duct Static

- The positive static is measured
 - **Furnace:**
 - At the supply outlet and must be read between the furnace and the cooling coil.
 - **Air handler/MBVC:**
 - At the supply outlet.
- The negative static is measured
 - **Furnace:**
 - At the return plenum and must be read between furnace the and filter.
 - **Air handler:**
 - At the return plenum and must be read between air hander and the filter.
 - **MBVC:**
 - Between the modular blower and the cased coil

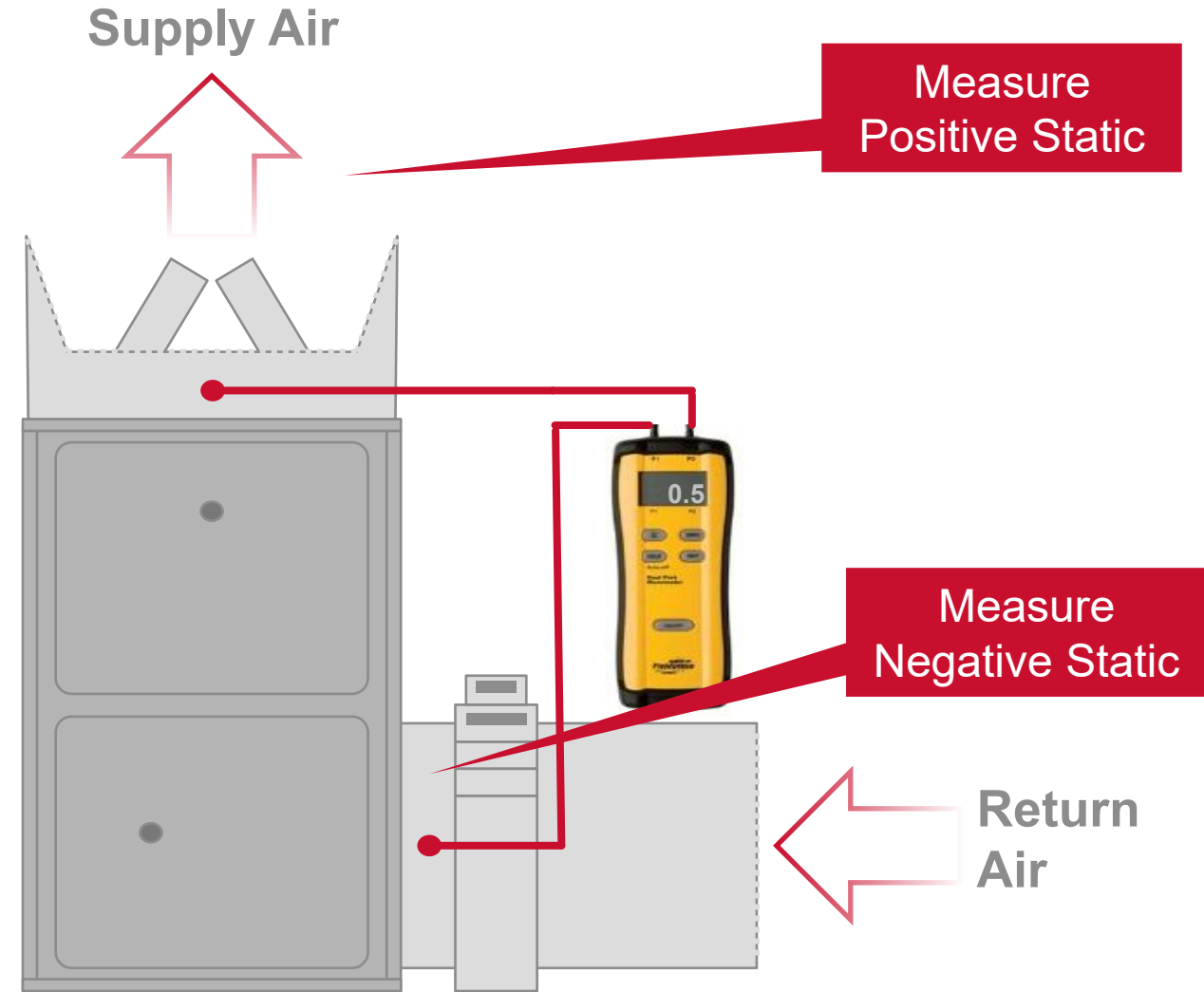

- Caution: Do not damage components within cased coil.

Static Pressure | Single Piece Air Handler

- On a single piece air handler, the evaporator coil has been installed at the factory and is already considered in static pressure calculation.
- Use a manometer to measure the static pressure of the air handler only.
 - Measure static pressure of the supply duct at the outlet of the air handler.
 - Measure the static pressure of the return duct at the inlet of the air handler.

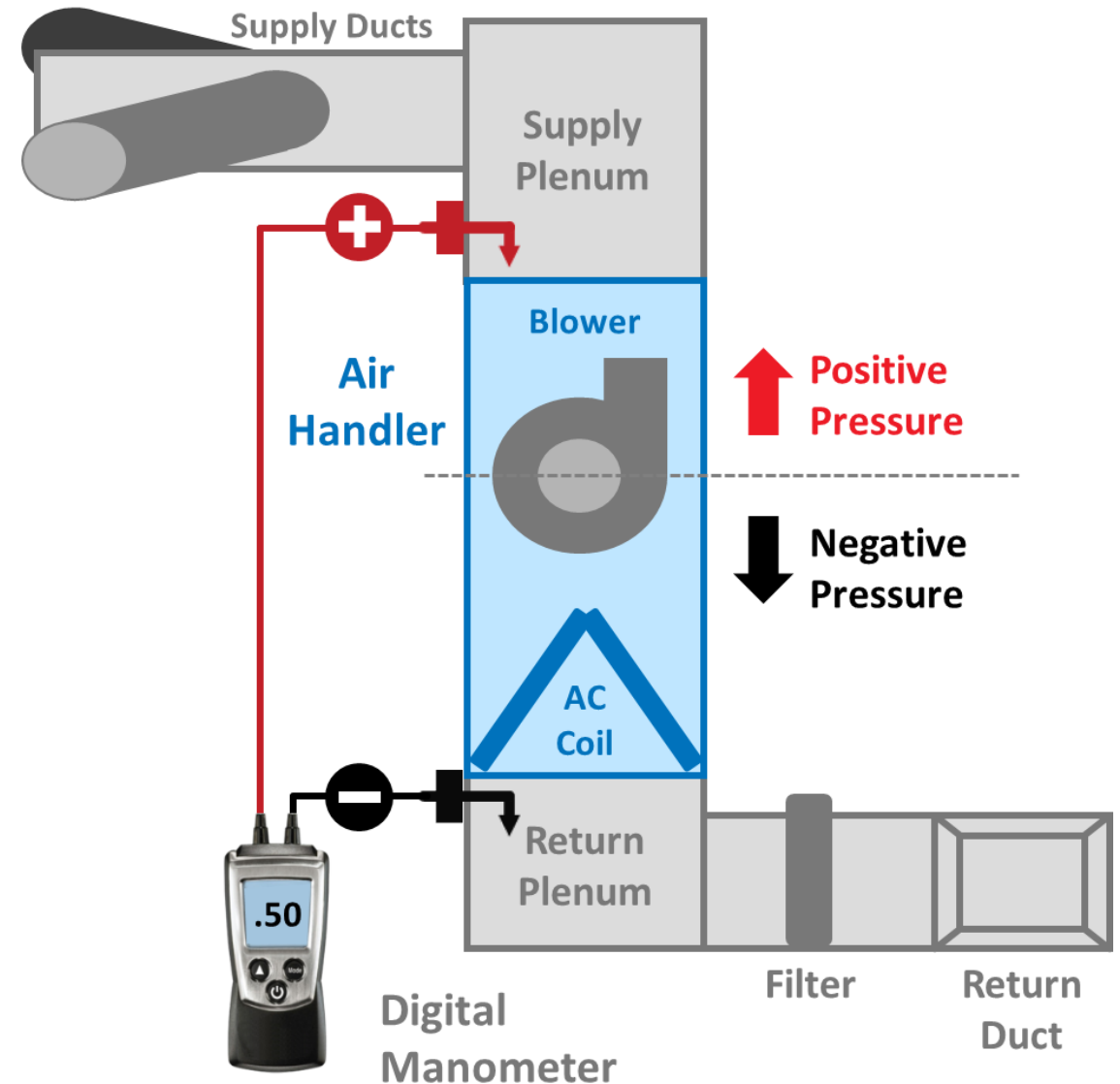

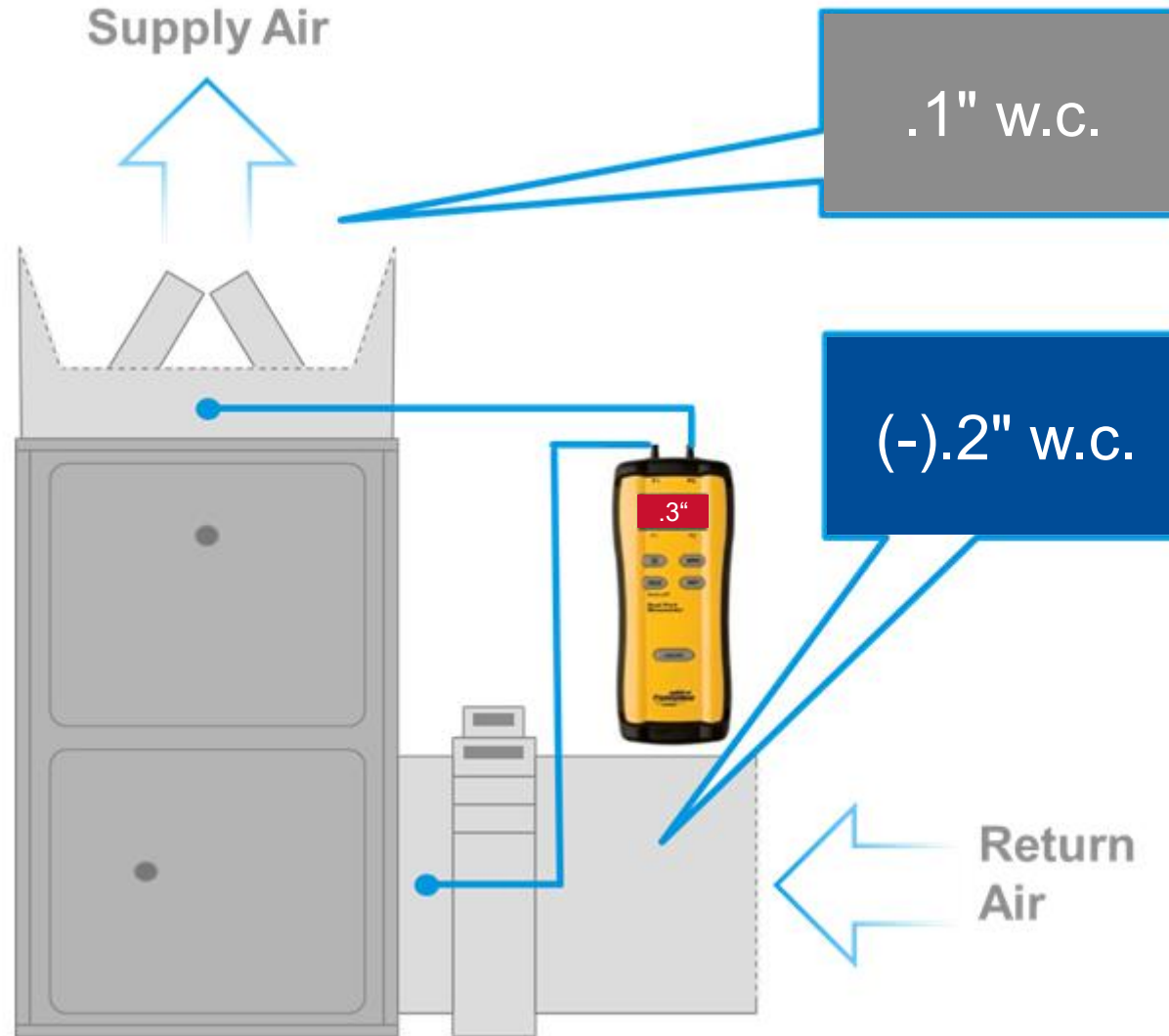

Boost Mode

- Boost mode allows the compressor to operate at a higher RPS (Revolution Per Second) than factory maximum.
 - Max. RPS value is hard coded into the software and cannot be changed.
- Cooling boost mode outdoor activation temperature can be adjusted in the boost mode menu.
 - Boost mode will operate after the ambient temperature increases beyond the selected activation temperature and the compressor has achieved its max RPS.
- Heating boost mode is enabled/disabled by selecting On/Off.
- On Amana Smart Thermostats you may select the max. RPS offset.
 - This allows you to adjust ± 10 RPS from the factory max. RPS

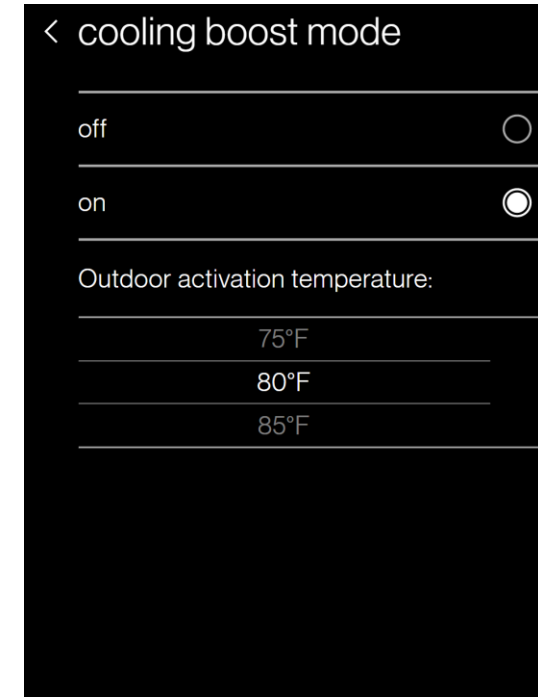
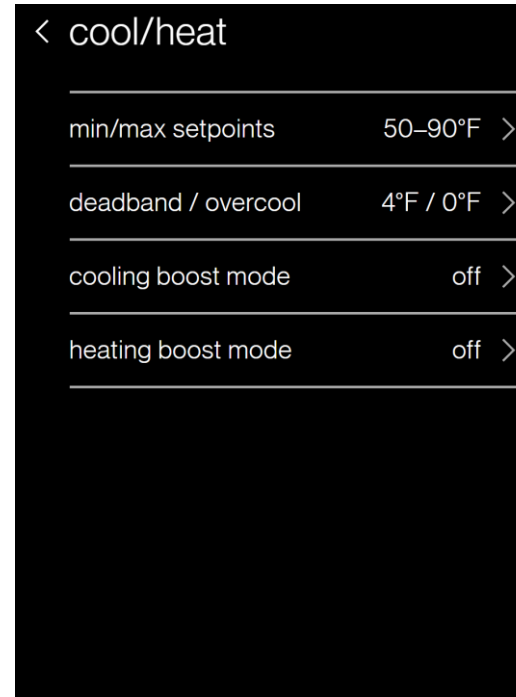

Cased Coils

Amana S-Series Installation and Commissioning
Technical Training Module: TRV-6.3



Rest assured.
It's an Amana® brand.



© 2022 Daikin Comfort Technologies North America, Inc.
Amana® is a registered trademark of Maytag Corporation or its related companies and is used under license.
All rights reserved.



Agenda

Installation

Additional Transformer for PCB

Control Panel and Wiring

Dip Switches



Horizontal right and left installations (front view)

- The CHPE coil is bi-directional and can be installed in either a left or right direction.
- CHPE coils are designed for indoor installation only and are installed on the discharge air side of a furnace.
- They should be installed on the return air side of a modular blower.

Note: The coil must be installed with the line set and drain openings to the front of the furnace or modular blower.



Horizontal Right

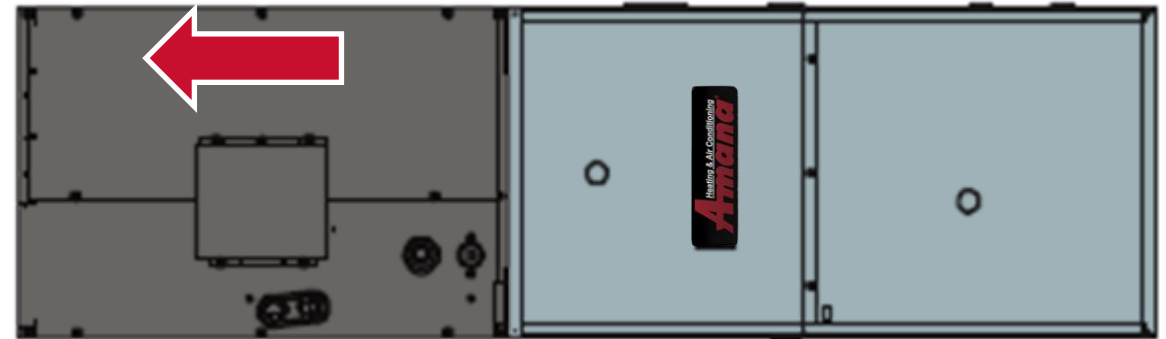

Horizontal Left

Installation

90 plus furnace install procedures

$\frac{1}{2}$ " to $\frac{3}{4}$ " tilt



Level end-to-end



Duct flange attachment

- There is no conversion required to reverse from a right to left application.
- Attach the duct flanges to the discharge side of the unit.
- If the coil and furnace combination are not similar in depth and width, use a field-supplied transition to center the furnace and coil openings.

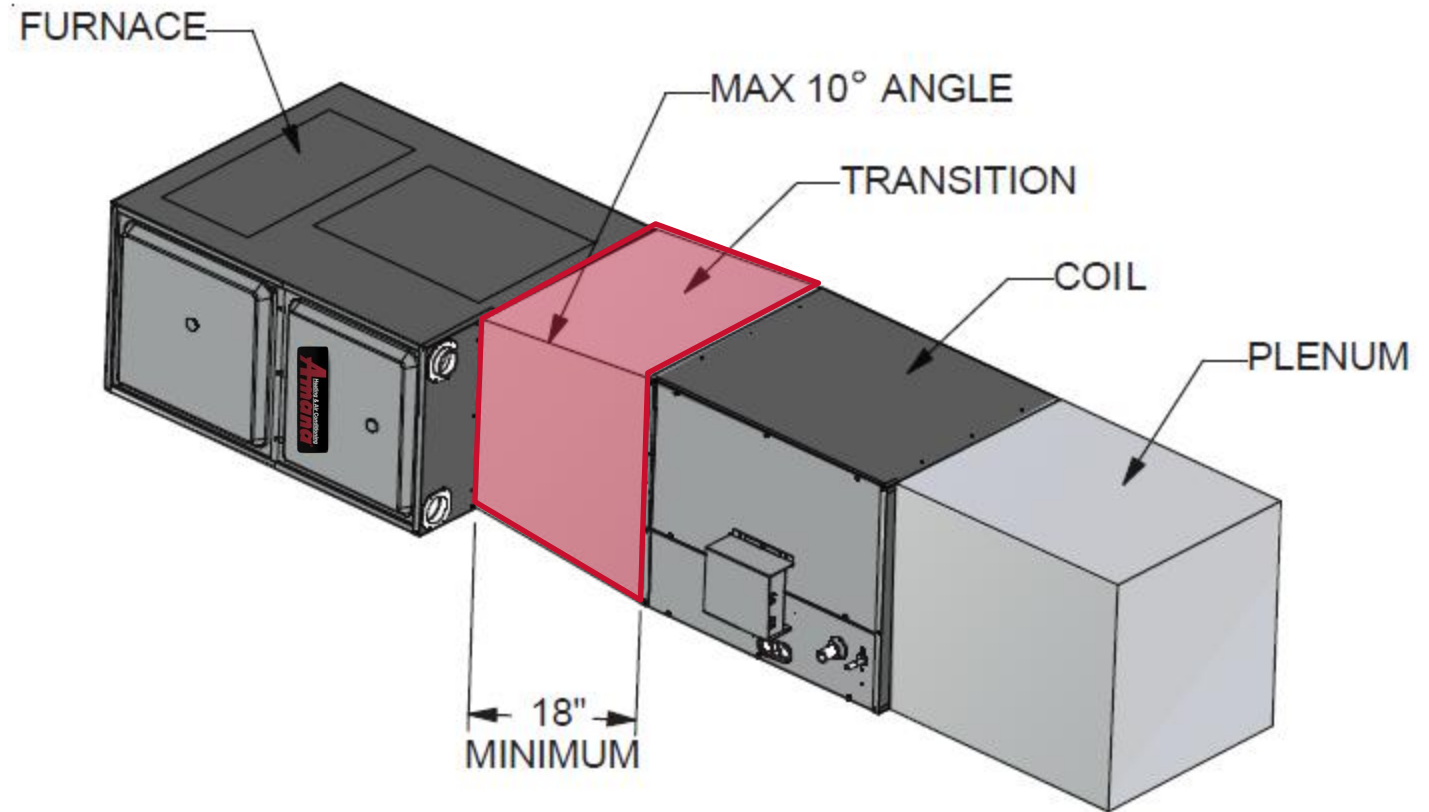

Z-Bracket Attachment

- The supplied Z-bracket attachment should be used to attach the coil to a narrower furnace, when a furnace is one size smaller than the coil.

Example: Coil height is 21.0" and furnace width is 17.5".

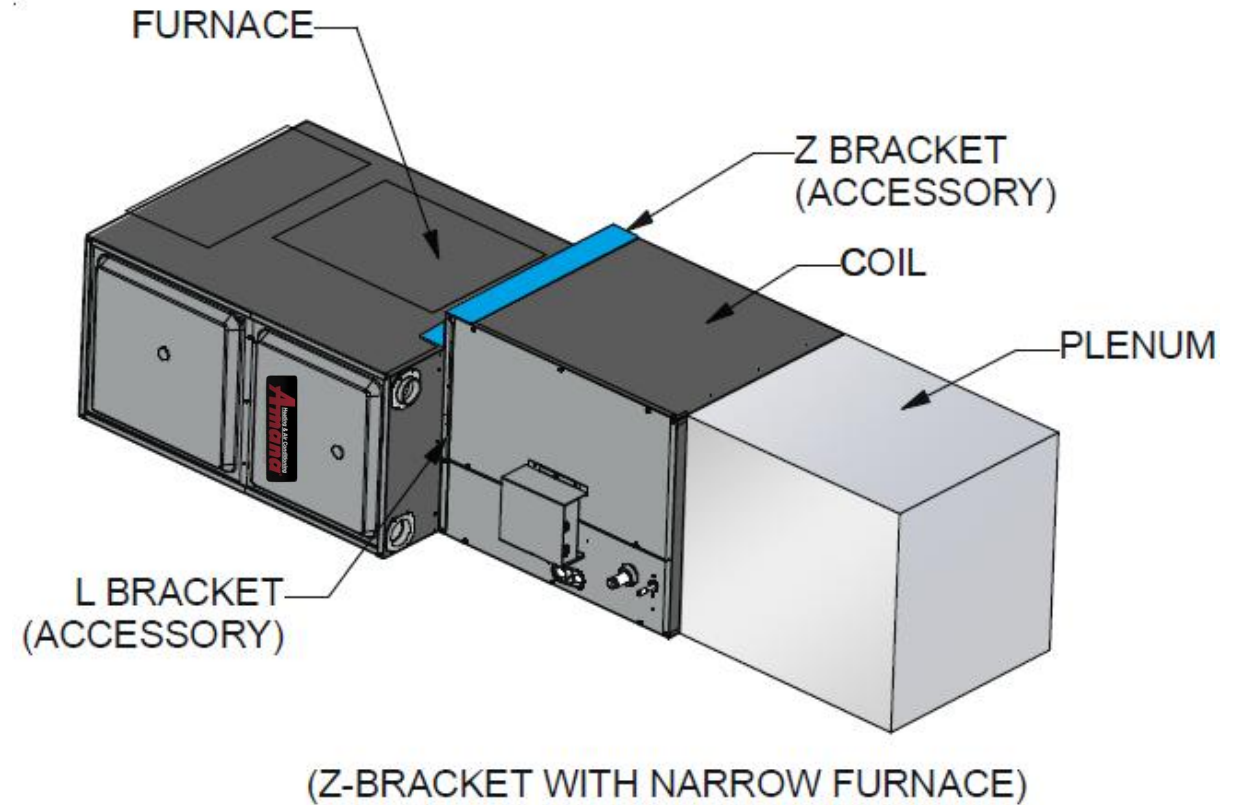
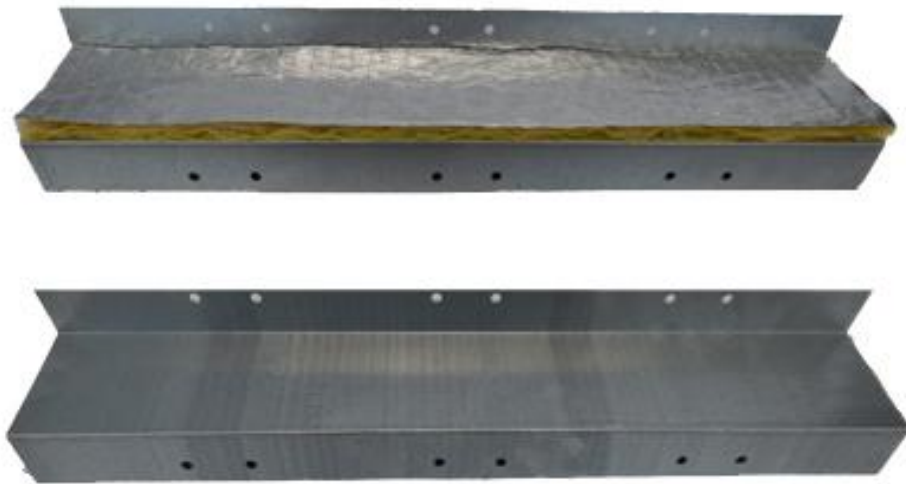

Installation

Stiffening/shipping bracket removal

- Prior to installation, remove the stiffening (shipping) bracket spanning the A-coil apex to the rear of the wrapper on all models.
- The bottom duct flange for the supply plenum side is shipped unattached.
- Carefully insert the flange into bottom rail and use a 5/16" screw to attach at the middle of the flange.
- Secure the side flanges with field procured 5/16" screws on the supply plenum side.

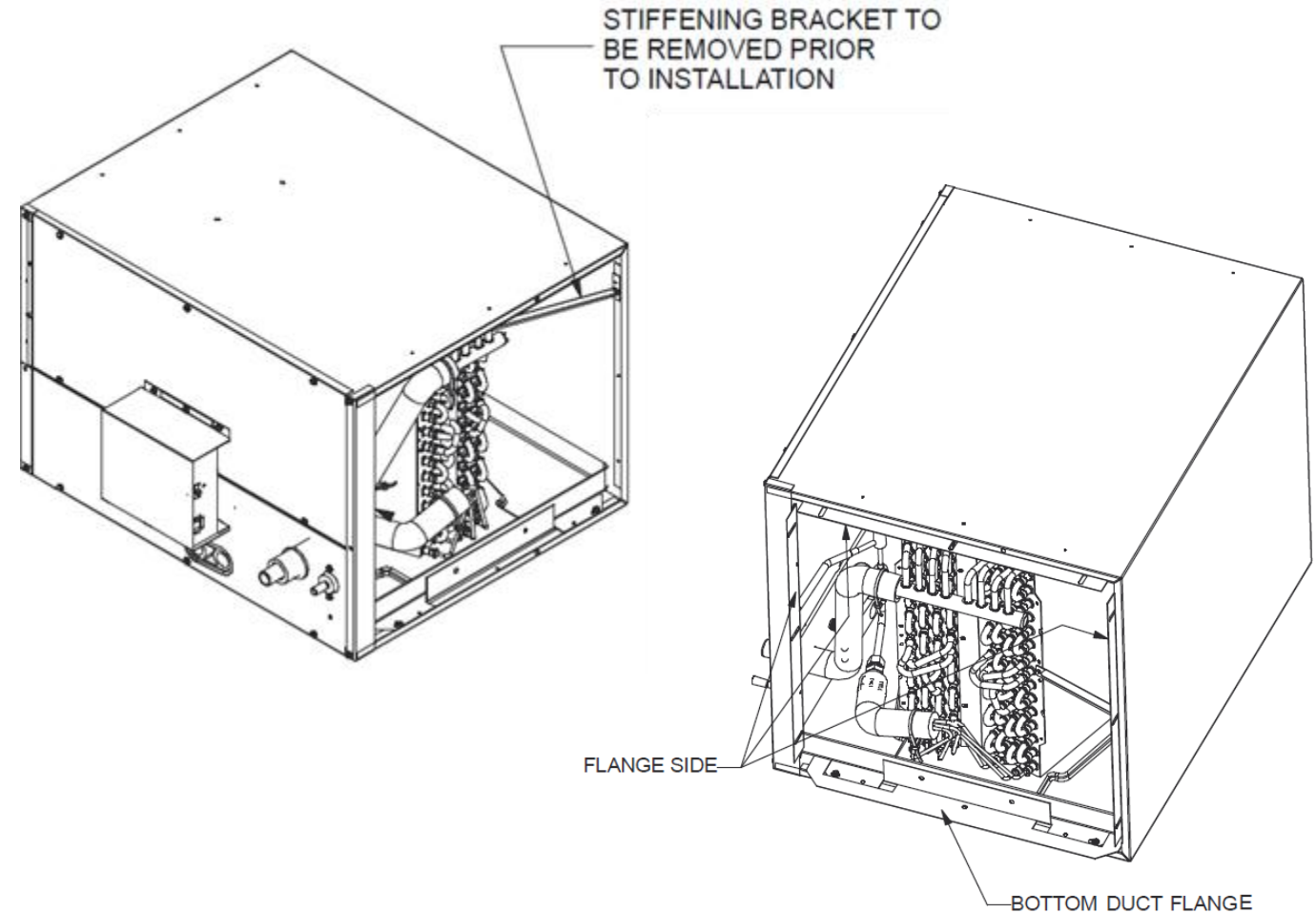

Installation

Z-bracket hardware and bracket kit

- Using the hardware and brackets provided, attach the coil to the furnace and plenum to the coil.

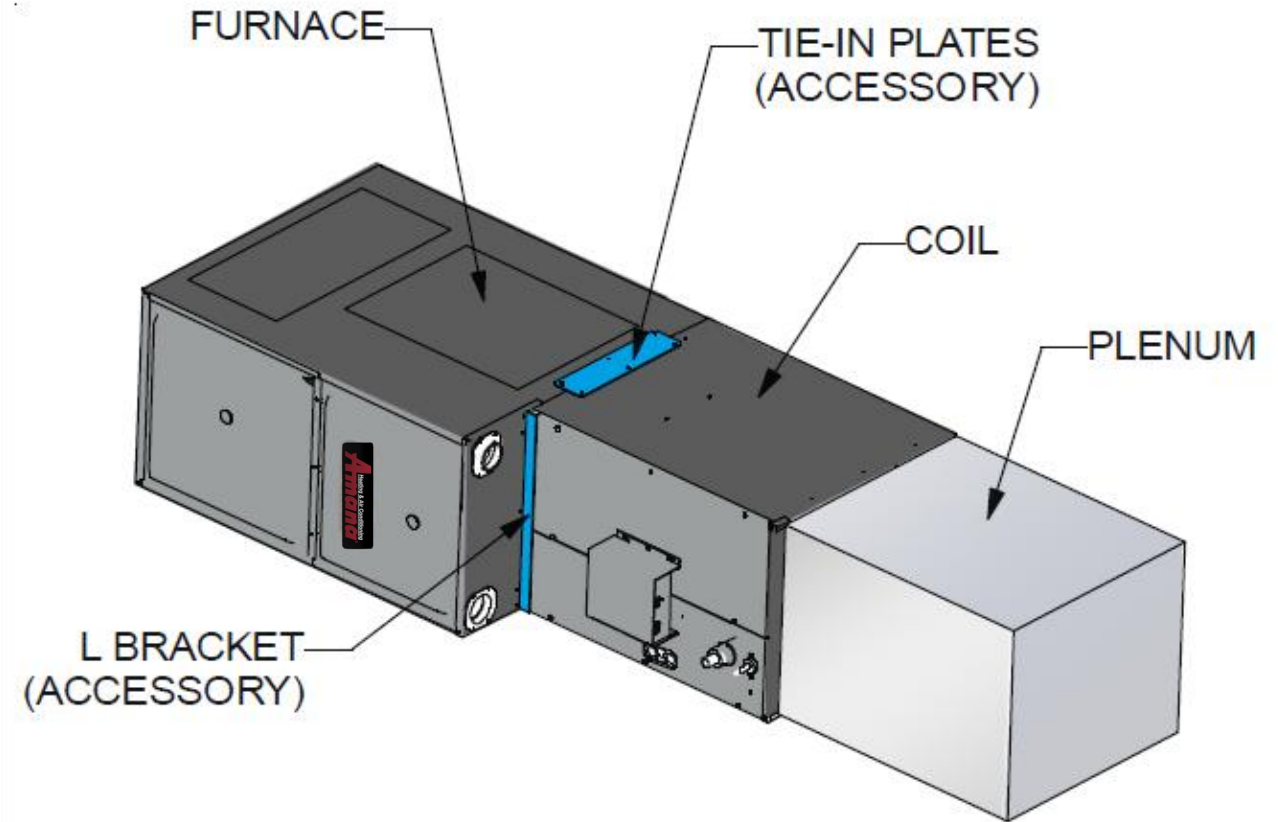
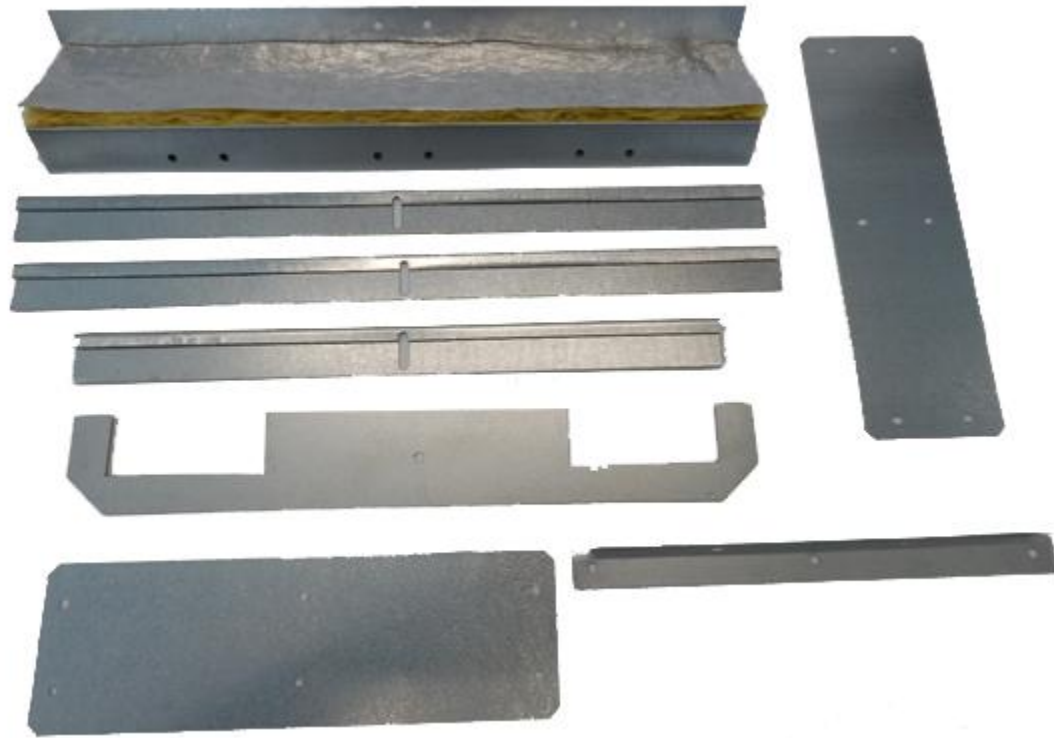

Installation

- Remove control panel from the right front panel to prevent component wiring damage.
- Removing the control panel allows the wiring to be safely pushed through the panel wire-way.
- Remove 4 mounting screws to detach control panel from the right front panel.

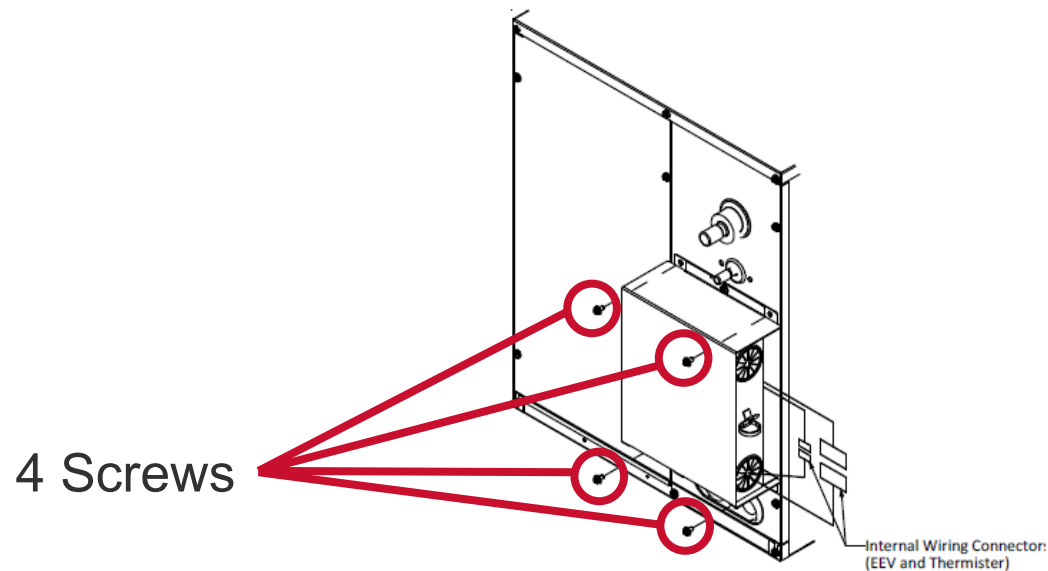

Installation



- A cased coil is shipped containing nitrogen gas under 150 psig.
- Release pressure from the gas piping pressure release device before initiating piping work.

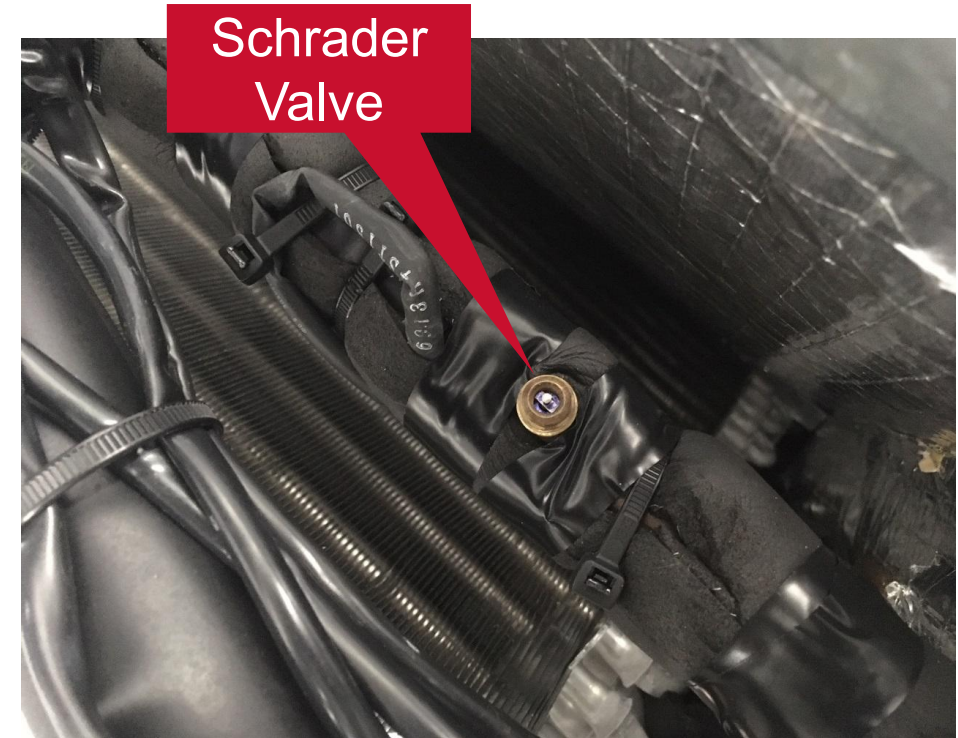
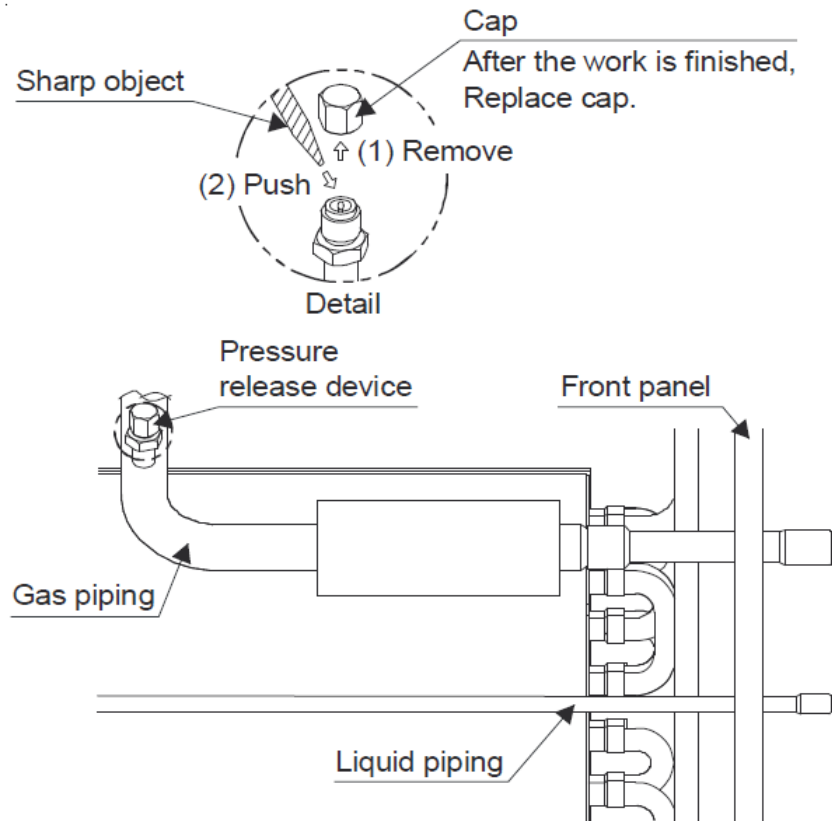

Installation



- When brazing the indoor coil, make sure to protect the pipe going into the coil by wrapping with a wet cloth.
- This will protect heat from transferring to the pipe and damaging the sensors on the indoor coil piping.

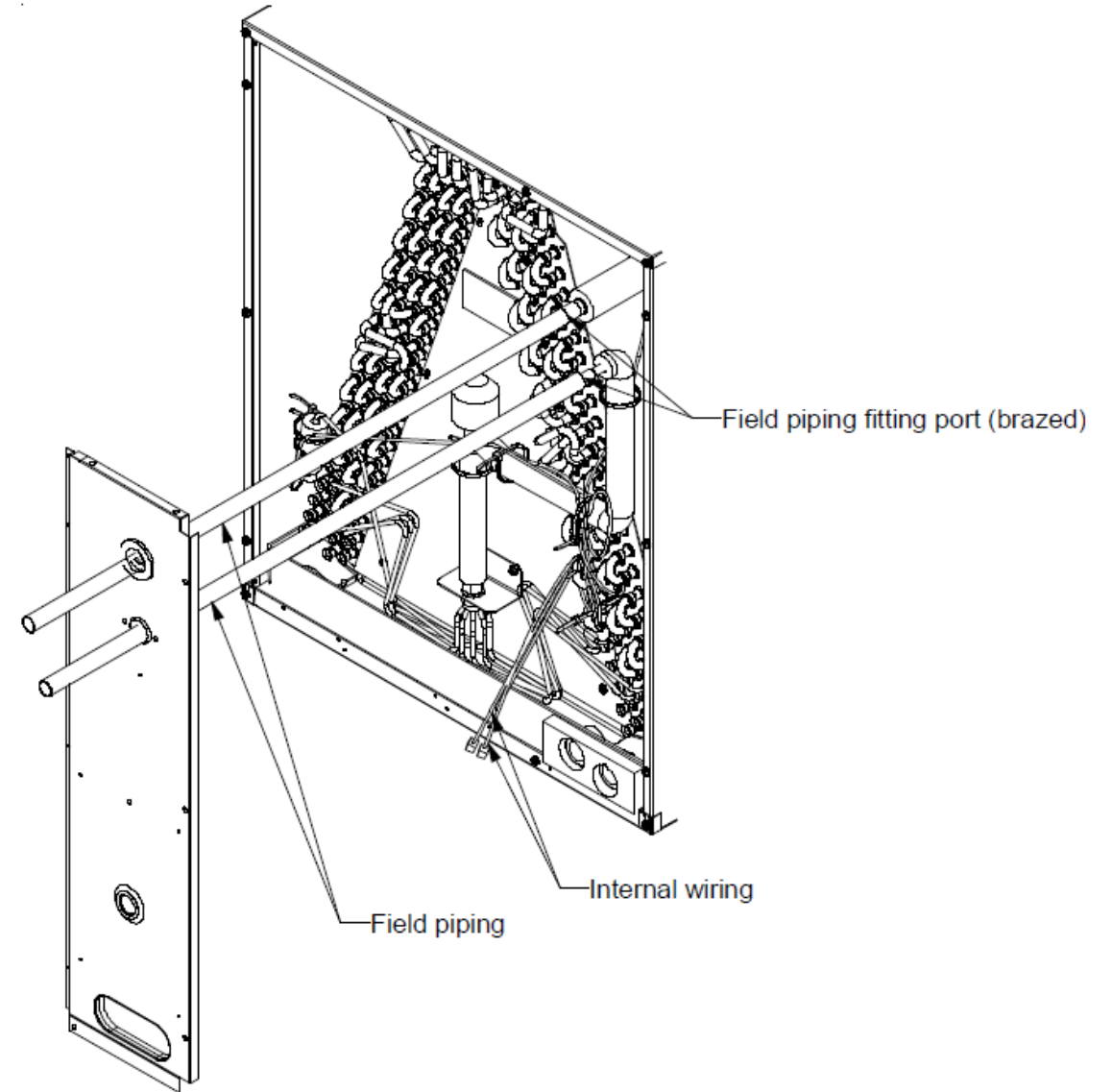
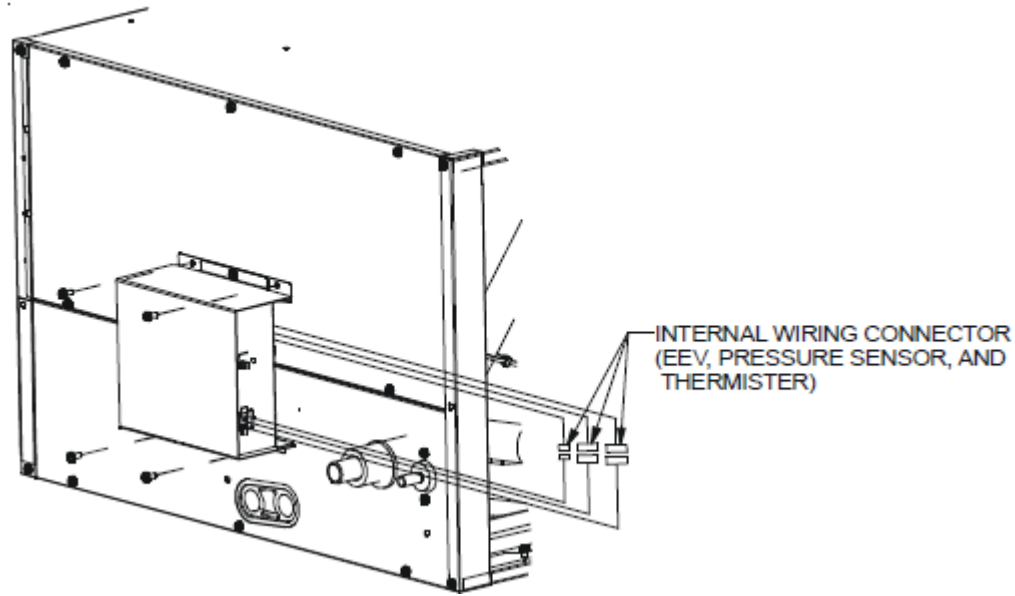

Installation

- A secondary (port B) condensate drain connection is provided for areas where local codes require it.

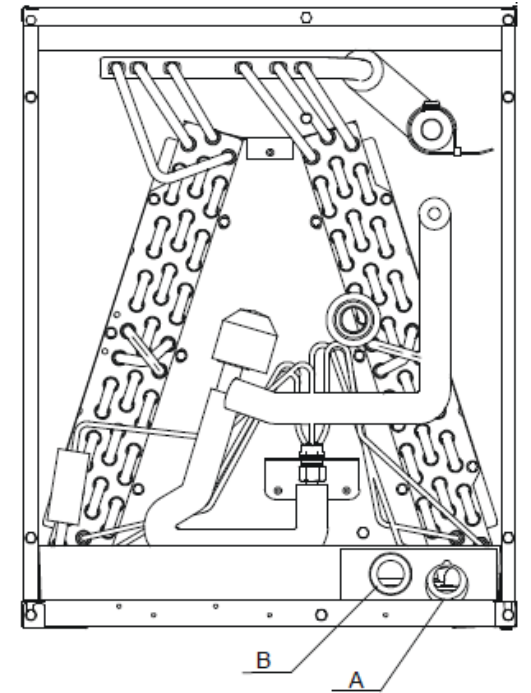
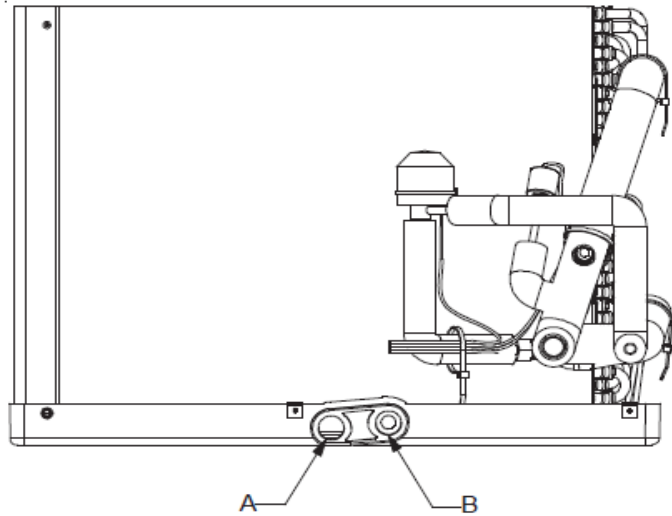

Additional transformer to power cased coil control panel/PCB

- A transformer is shipped with the EEV coil and will be mounted in the gas furnace and MBVC.
- The purpose of this transformer is to power the printed circuit board on the EEV coil.
- The kit includes two (2) brackets that allow the transformer to be installed inside the furnace cabinet. (brackets are labeled A and B)
- The install instructions that come with the EEV coil show the proper way to mount the transformer.

	Model Name	Cabinet Width	Bracket Select		
			Bracket A	Bracket B	No Bracket
Gas Furnace	AMVC80*	All	✓		
	AMVC96*	All		✓	
	AMVM97*	All		✓	
	ACVC80*	All			✓
	ACVC96*	17.5"			✓
	ACVM97*				✓
	ACVC96*	21.0"		✓	
	ACVM97*	24.5"		✓	
Modular Blower	MBVC**00	All			✓

Transformer Installation

Mounting bracket 'A' inside of furnace

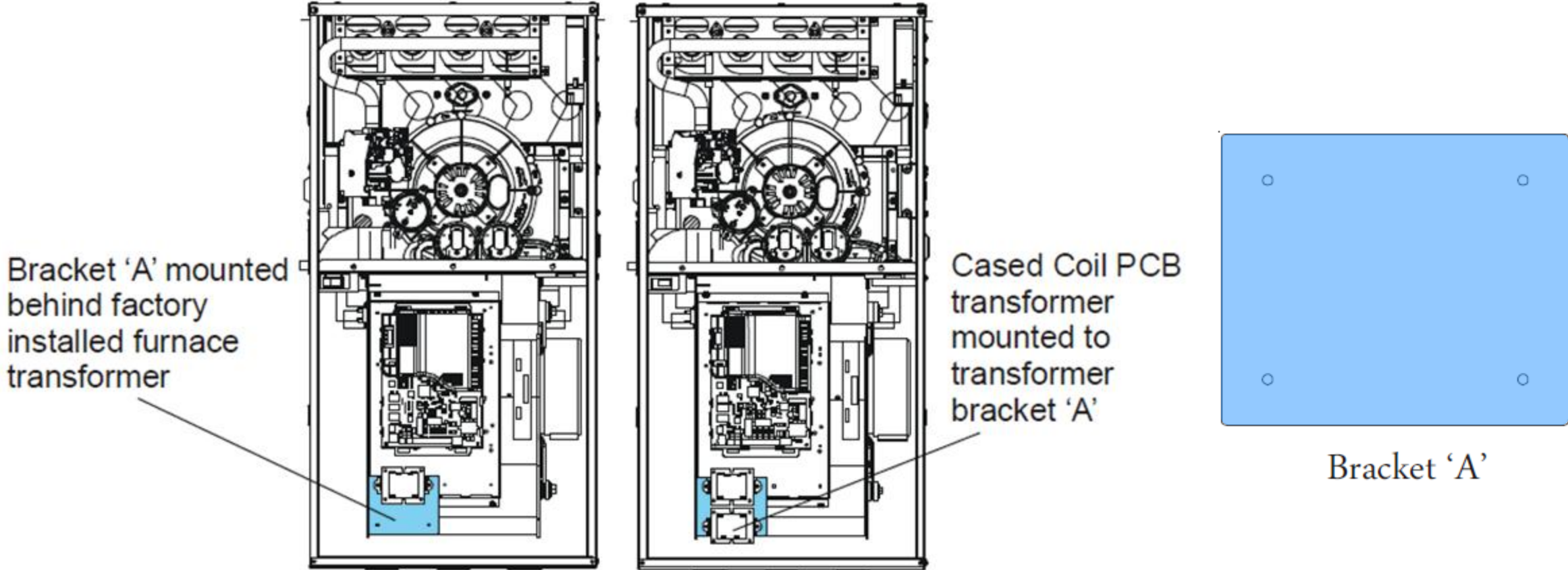

Transformer Installation

Mounting bracket 'B' inside of furnace

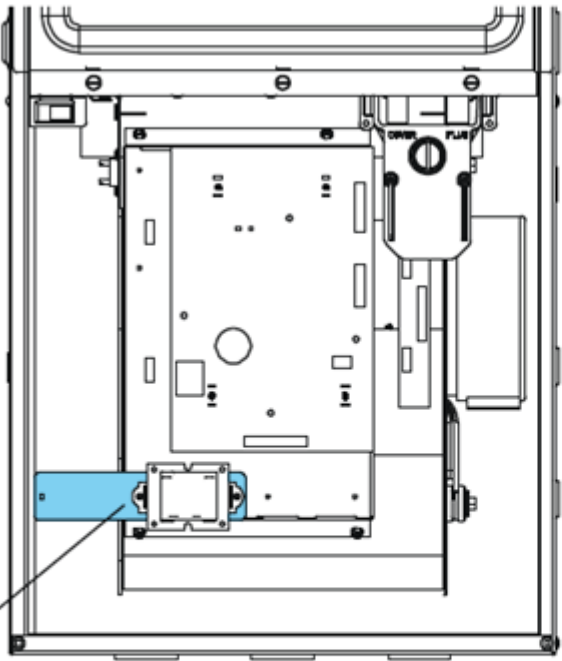

Bracket 'B' mounted behind factory installed furnace transformer

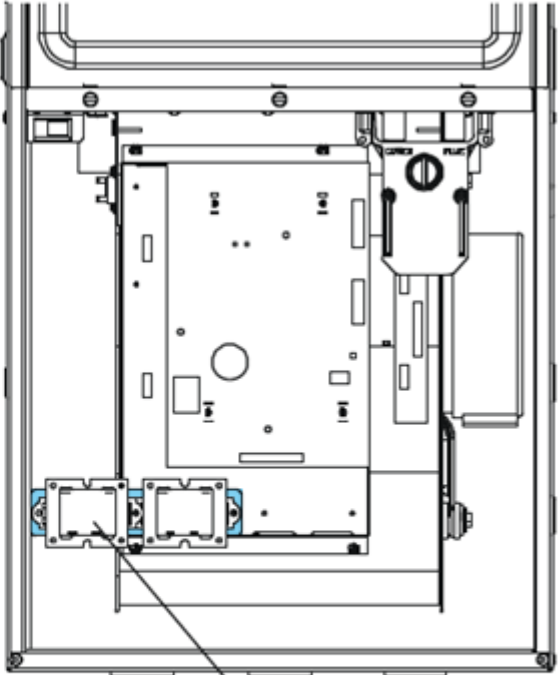

Cased Coil transformer PCB mounted to transformer Bracket 'B'

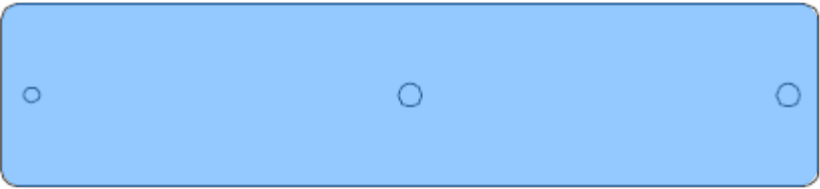

Bracket 'B'

Transformer Installation

Wiring PCB transformer using furnace power

- Use the red and black wires provided in the transformer kit.
- Connect one end of the red and black wires to the high voltage side of the transformer. (com and 120VAC)
- Connect the other end of the red and black wires to the power source in the furnace high voltage junction box.

Optional: Communicating furnace PCB's have line voltage accessory terminals that will allow the transformer to be powered from the furnace board. (if not being used)

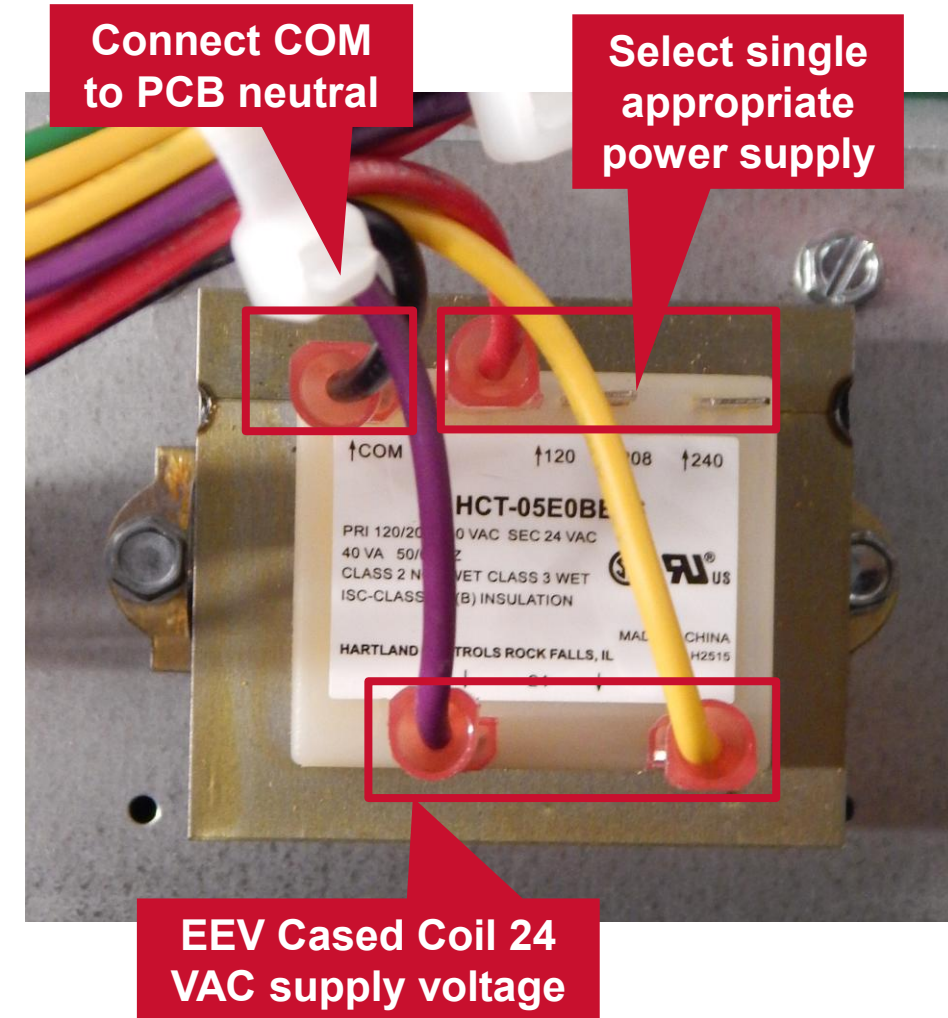

Transformer Installation

Transformer wiring using furnace power

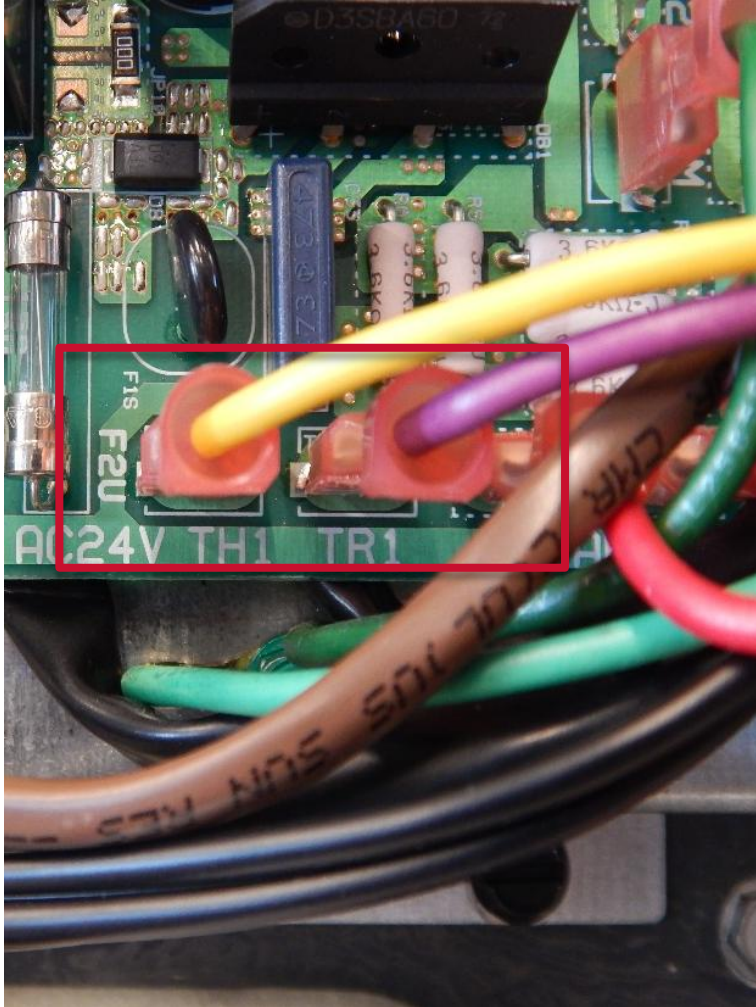

- This transformer supplies 24 VAC to the coil PCB's, via the yellow and purple wires in transformer kit.
- Do not supply high voltage to the EEV coil PCB, as it will cause a failure of the PCB.

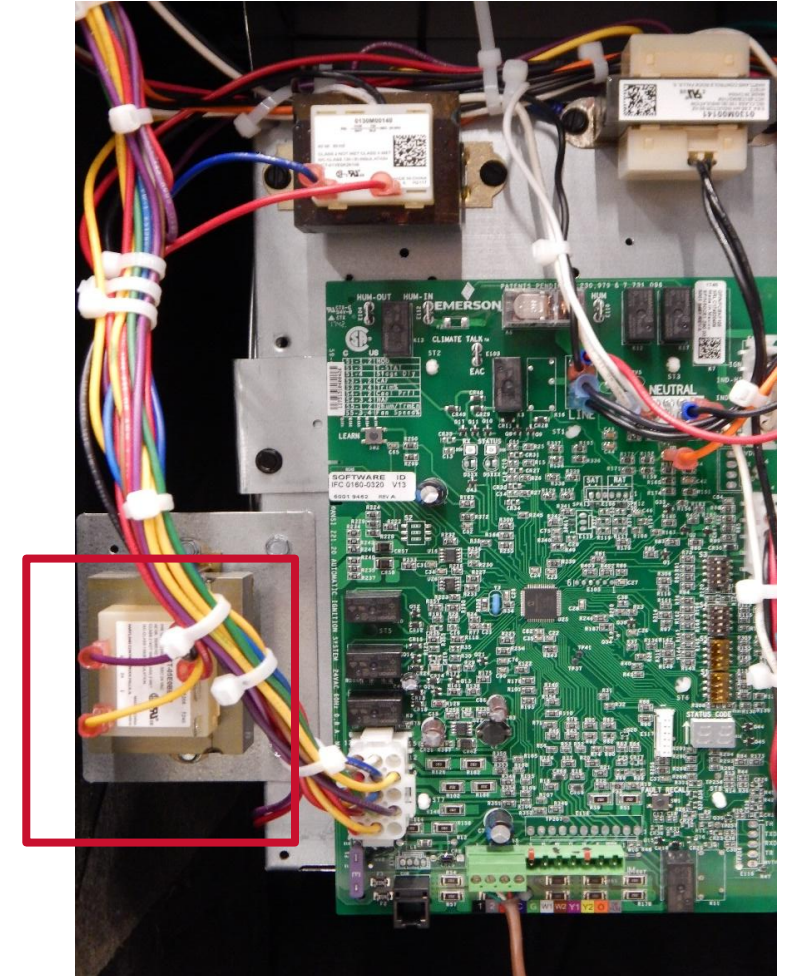

Agenda

Installation

Additional Transformer for PCB

Control Panel and Wiring

Dip Switches



CAPE/CHPE control module

- The control module is mounted on the exterior of the casing and is prewired.

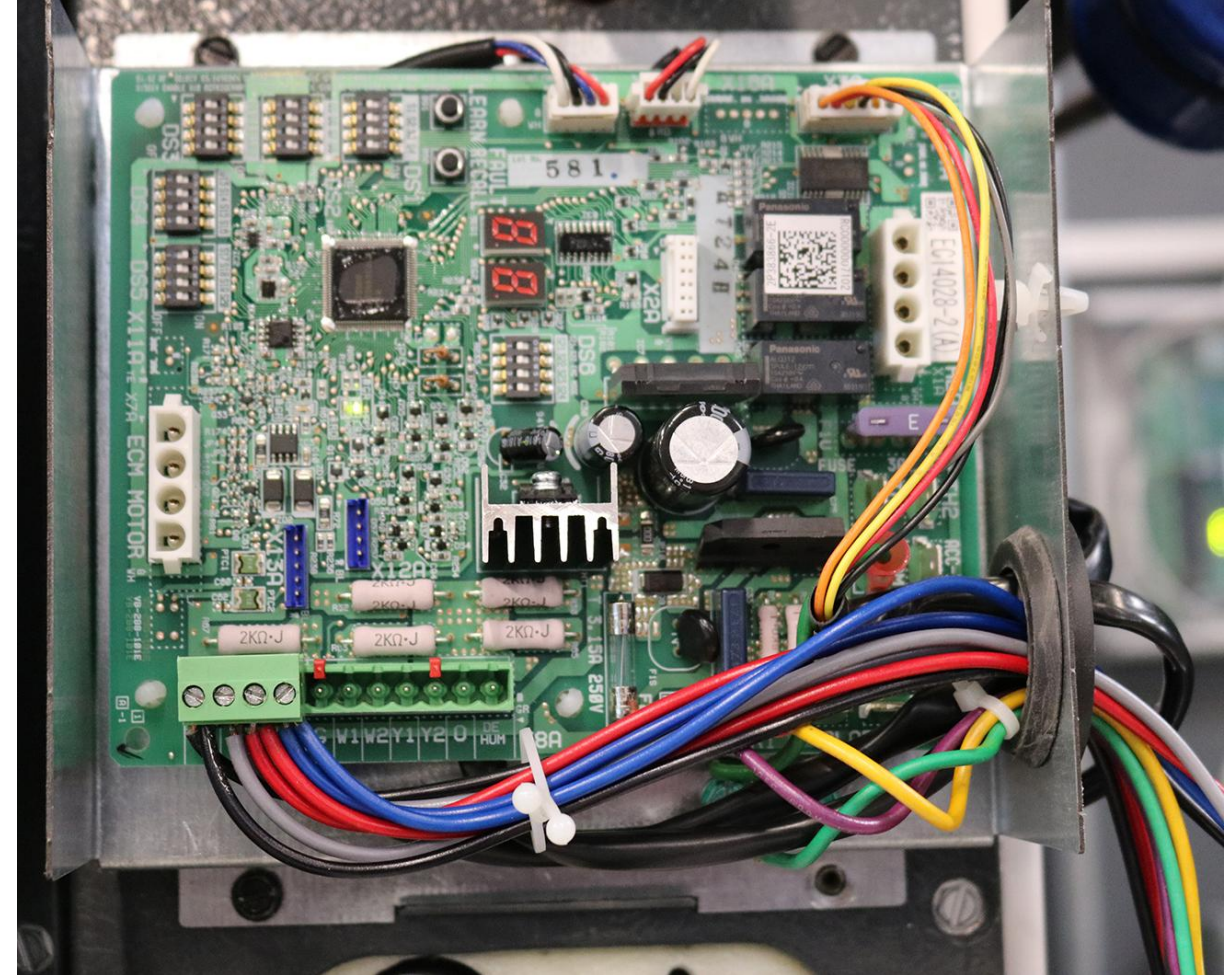

Control Panel and Wiring

Low voltage connections on the CAPE and CHPE PCB's

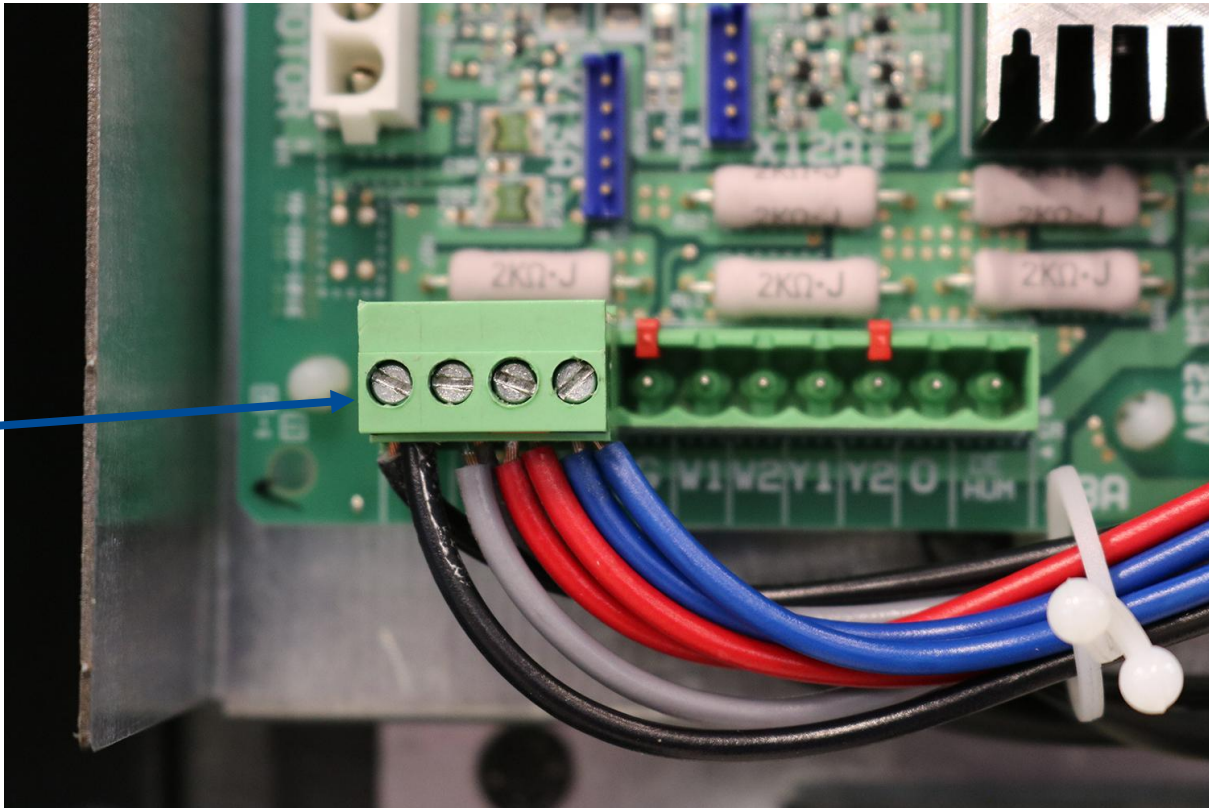
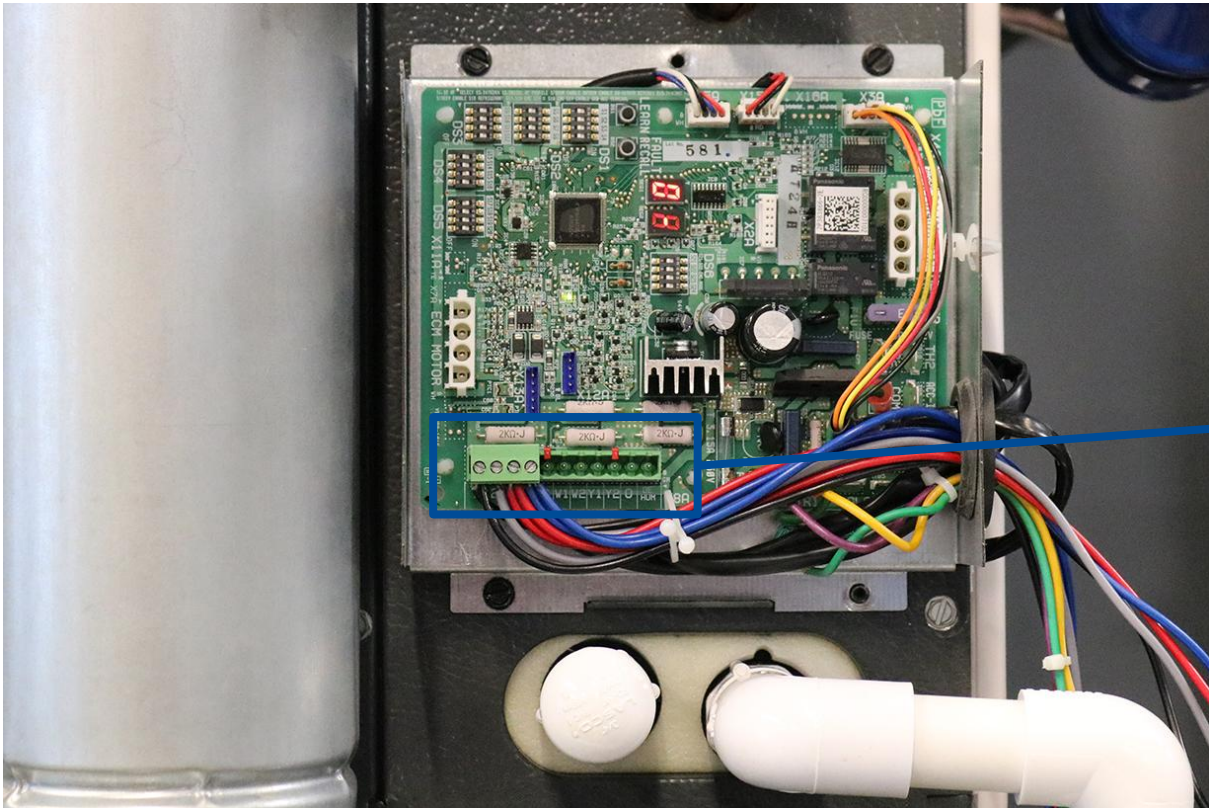

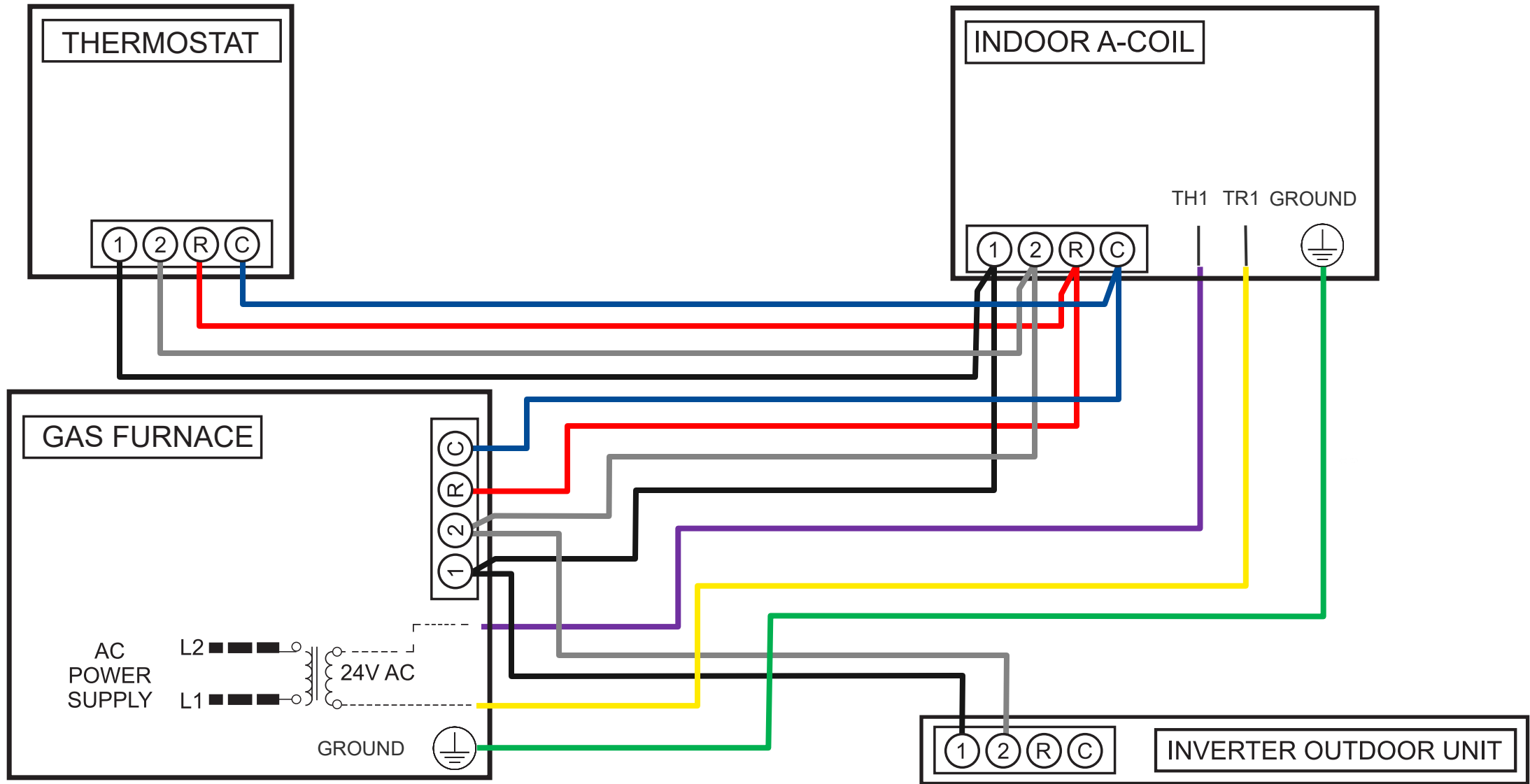

Auxiliary Alarm

24VAC auxiliary alarm switch (communicating set up ONLY)

- Primarily to be used for a condensate switch input.
 - Must remove jumper prior to adding the condensate switch.
- AUX switch is normally closed
 - Opens when the water level in the evaporator coil base pan has reached an undesirable level
- The Aux alarm will respond by turning off the outdoor unit and display EEF on the LED display.
- If the AUX switch is detected closed for 30 seconds, normal operation resumes, and error message no longer displayed.
- In the Amana Smart Thermostat dealer edit menu, under 'equipment set up', select the furnace and then select 'add alarm'.

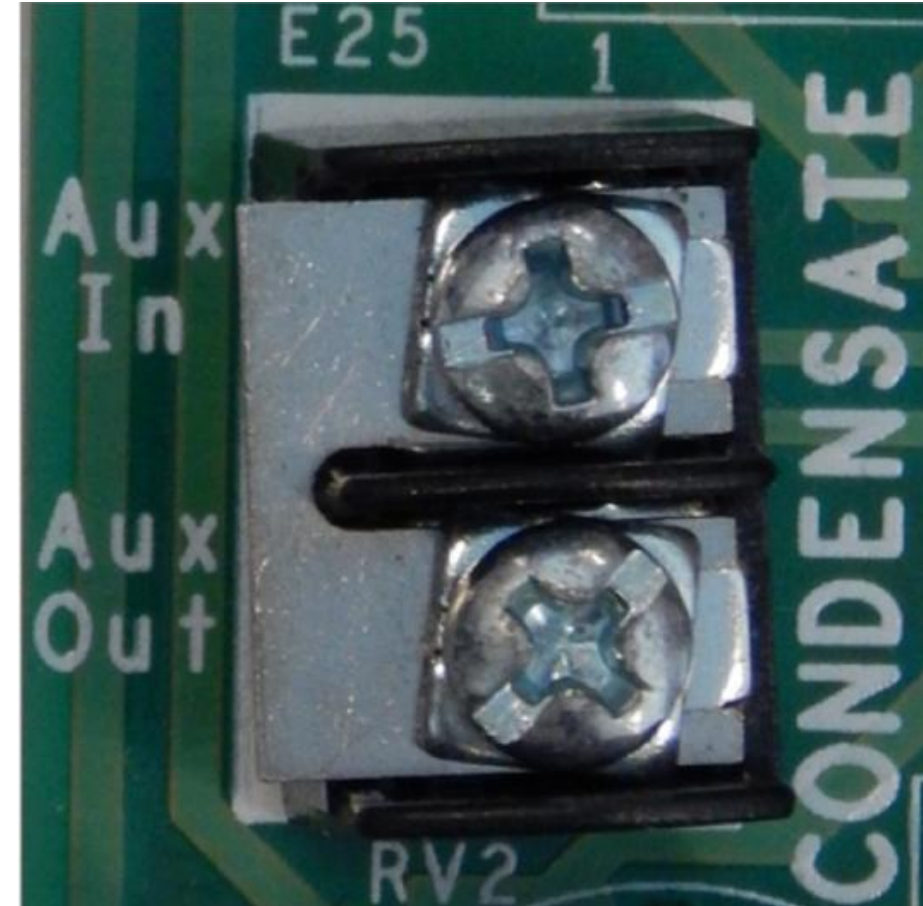

Auxiliary Alarm

MBVC

- The condensate alarm switch (CAS) terminals can only be utilized with communicating mode setups and must be enabled with a communicating thermostat.
 - In the Amana Smart Thermostat dealer edit menu, under 'equipment set up', select the equipment and then select 'add alarm'.

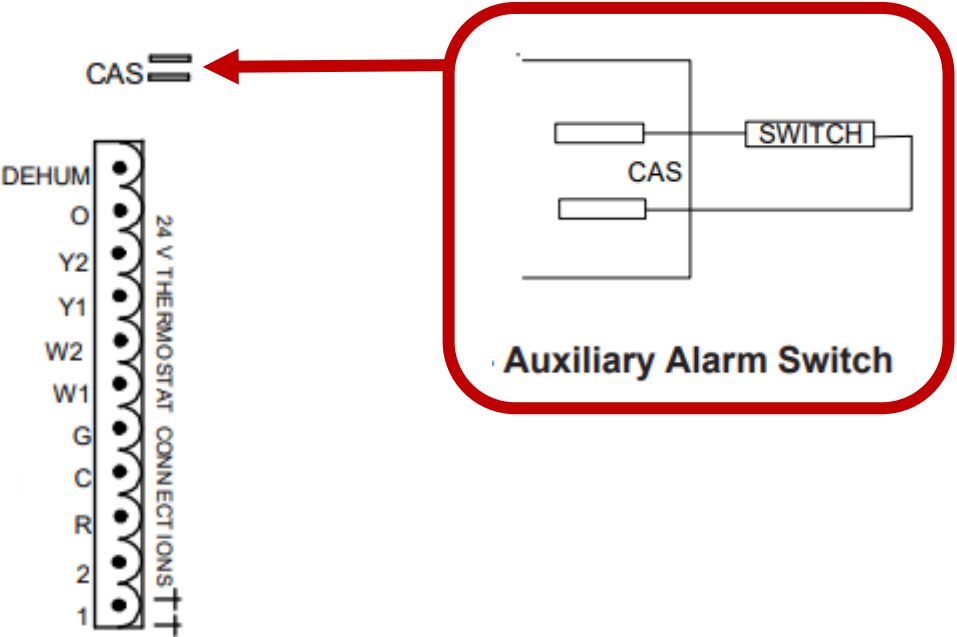

Agenda

Installation

Additional Transformer for PCB

Control Panel and Wiring

Dip Switches

AHVE Air Handler

Amana S-Series Installation and Commissioning
Technical Training Module TRV-6.4



Rest assured.
It's an Amana® brand.



© 2022 Daikin Comfort Technologies North America, Inc.
Amana® is a registered trademark of Maytag Corporation or its related companies and is used under license.
All rights reserved.



Agenda

Air Handler Installation and Coil Removal

Wiring Diagram and Plug ID

Dip Switches

Heater Kits

- The AHVE may be installed in upflow, downflow, horizontal left or horizontal right orientations.

Note: The AHVE is factory ready for upflow and horizontal left installs.

AHVE Installation

Upflow

- No field modifications are mandatory however to obtain maximum efficiency, the horizontal drip shield, side drain pan and drain pan extension, can be removed.

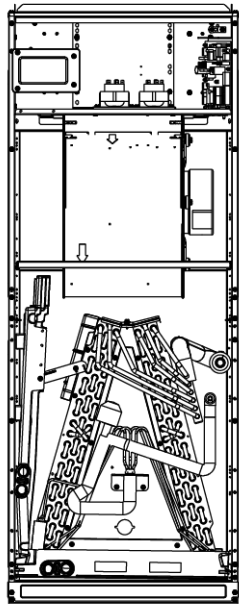

UPFLOW

Horizontal Left

- No field modifications are necessary for this application.

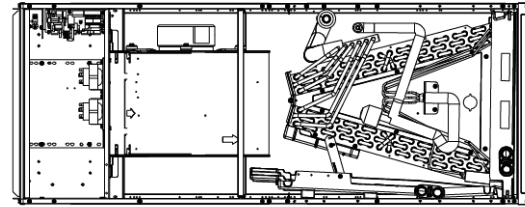

HORIZONTAL LEFT

Downflow/Horizontal Right

- In the downflow application, to prevent coil pan “sweating”, the mandatory downflow kit (DFK) is available through your local distributor.

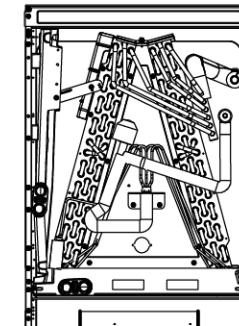

DOWNFLOW

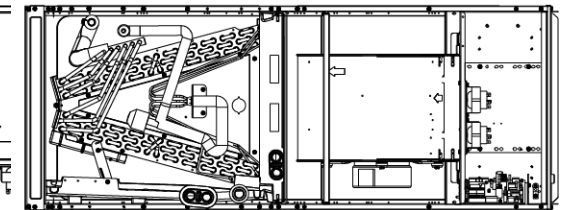

HORIZONTAL RIGHT

AHVE Installation

Drain pan extension

**Drain Pan
Extension
Removed**

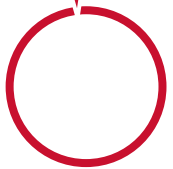
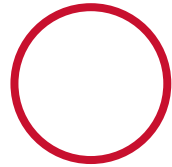

- The image below displays the drain pan extension that must be removed in a horizontal right installation.



Removing Coil

1 Remove cabinet doors



2 Cut wire ties at center support

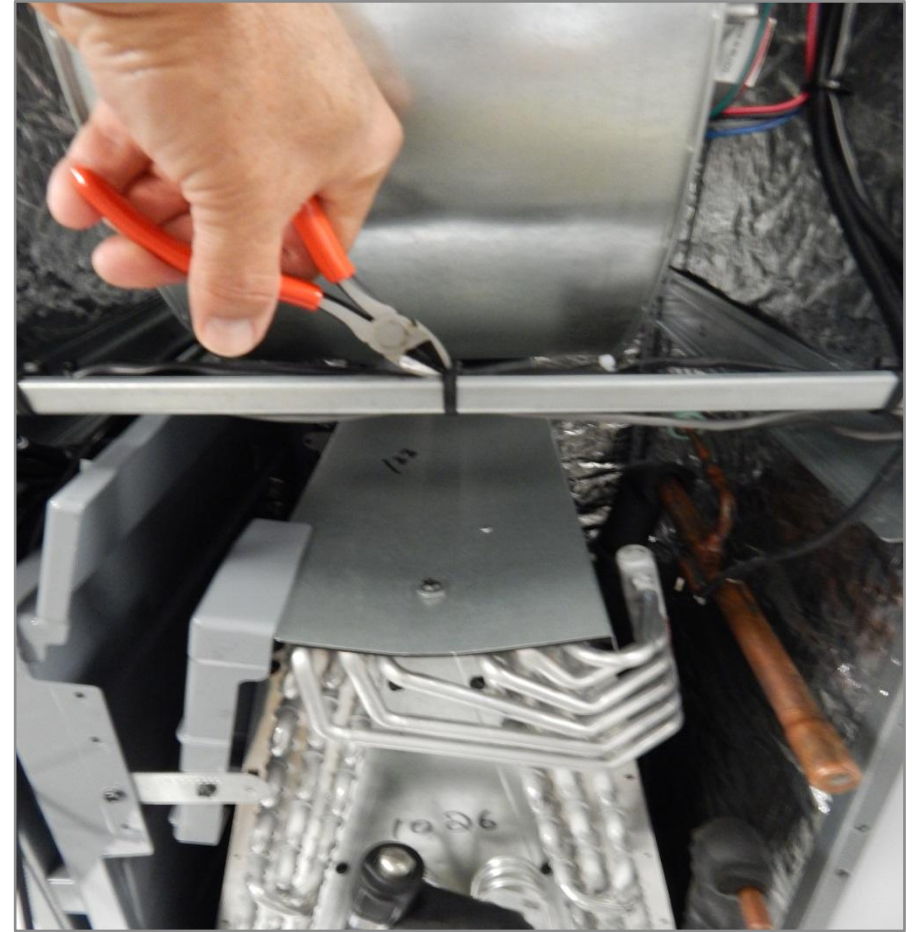

Removing Coil

3 Carefully pull coil half out



4 Locate wiring harness



Removing Coil

5 Cut wire ties and peel back tape

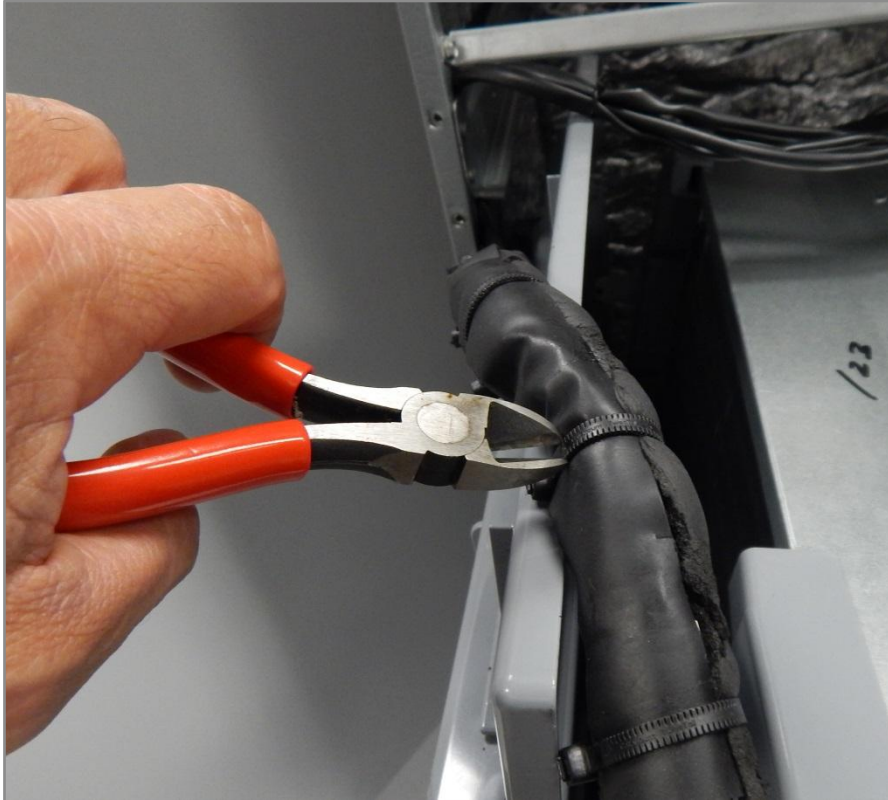

6 Carefully separate insulation



Removing Coil

7 Remove insulation



8 Disconnect plugs & remove coil

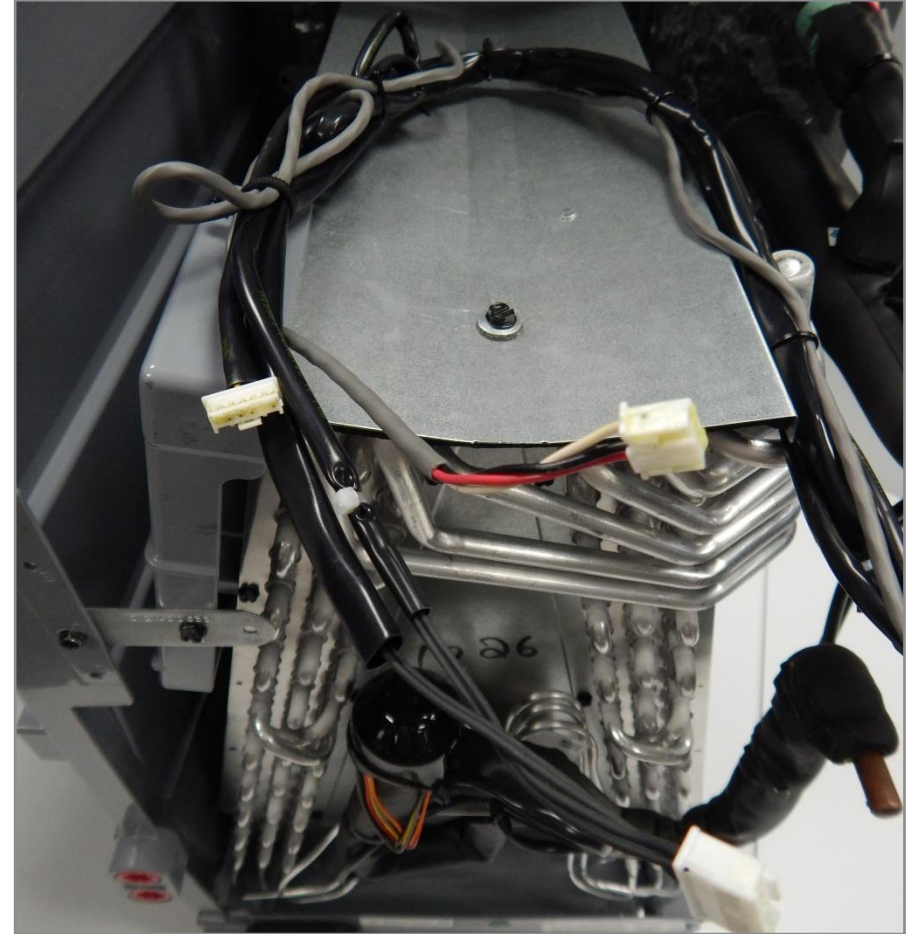

Rotate and Replacing the Coil

1 Match slots on the drain pan to the rails



2 Reattach, insulate, and secure the wiring harness





Electrical and control wiring

- Routing of electrical wiring must be made through the electrical knockouts provided on this air handler.
- When removing the electrical knockouts, take care not to damage the PCB.
- Do NOT cut, puncture, or alter the AHVE cabinet for electrical wiring.
- Knockouts on the cabinet sides are used for electrical conduit.
 - If the diameter of the conduit is different than the knockout, an adapter ring must be used in order to meet UL1995 safety requirements.

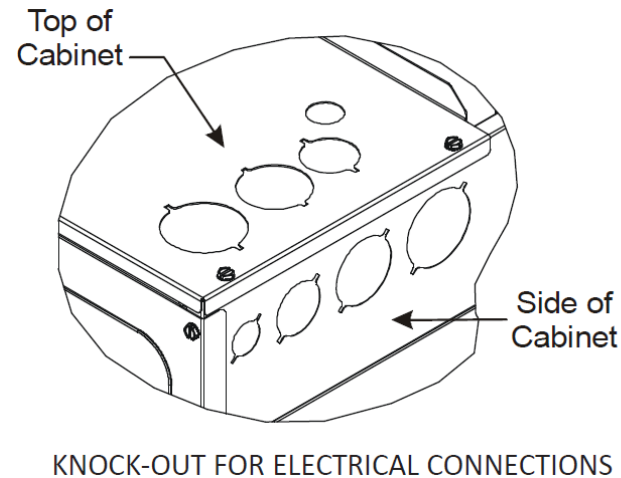

AHVE Installation

Maximum overcurrent protection

- Every installation must include an NEC (USA) and CEC (Canada) approved overcurrent protection device.
- Check with local or state codes for any special regional requirements.
- Protection can be in the form of fusing or HACR style circuit breakers.
- The series and rating plate provides the maximum overcurrent device permissible.

MODEL NO. AHVE48CP1400AA SERIAL NO. 2106753009

MOTOR	TEST EXTERNAL STATIC PRESSURE (INCHES) 0.5	
AMP+	H/P MAXIMUM OUTLET TEMPERATURE 200°F.	
5.2	3/4 0 INCH CLEARANCE FROM CABINET, PLENUM AND DUCT, FOR INSTALLATION.	
LABEL PART NO. SR3A00223		

208/230 VOLTS 60 HERTZ 1 PHASE

WHEN INSTALLING ONE OF THE ACCESSORY HEAT KITS, PERMANENTLY IDENTIFY THE MODEL ON THIS PLATE.

MARK HERE	HEATER KIT MODEL USED	Wt. (LBS)	CIRCUIT 1			CIRCUIT 2			SINGLE POINT KIT	
			H.A.	M.C.A.	M.O.P.	H.A.	M.C.A.	M.O.P.	M.C.A.	M.O.P.
	NO HEAT KIT		0.000	8.56.5	15/15					
	HKC15KXC		17.300.0	28/32	30/35					
	HKC15KXC		21.725.0	34/38	35/40					
	HKC15KXC		28.903.3	43/48	45/50					
	HKC15KXC		34.740.0	50/57	50/60					
	HKC15KXF		00	6.56.5	15/15	30/34.6	38/43	40/45		
	HKSC15XA 208		34.7	49.8	50	17.3	21.7	25	71.5	80
	HKSC15XB 240		40	58.5	60	20	25	25	81.5	90
	HKSC19CA 208		34.7	49.8	50	34.7	43.3	45	93.2	100
	HKSC19CB 240		40	58.5	60	40	50	50	107	110

M.B.S. = MINIMUM BLOWER SPEED
H.A. = HEATER AMPS
M.C.A. = MINIMUM CIRCUIT AMPS
M.O.P. = MAXIMUM OVERCURRENT PROTECTION (C) = CIRCUIT BREAKER
A CIRCUIT 1 : SINGLE PHASE FOR AIR HANDLER
CIRCUIT 2 : THREE PHASE OR 15KW AND HIGHER HEATER KIT

SCCR_KA rms, Symmetrical @ 600V	
Unit + Heater Kit	Short Circuit Current Rating in KA
Units with Heater Kits rated 10KW or below	5
Units with Heater Kits above 10KW	

* INDICATES REVISION LEVEL THAT MAY OR MAY NOT BE DESIGNATED
+ MOTOR AMPS BASED ON TEST DATA
INDICATES MODEL A OR B. A IS 208V ONLY AND B IS 240V ONLY
MOTOR ELECTRICAL DATA IS INCLUDED IN CIRCUIT 1 AND SINGLE POINT KIT
THE 208 OR 240 IN THE HEAT KIT PART NUMBER FIELD IS FOR CLARIFICATION OF THE NOMINAL VOLTAGE FOR THIS MODEL.



AHVE Installation

High voltage wiring

- The power supply will be connected to the stripped back red and black wires in the air handler electrical compartment.
- Ground lug in upper right of air handler electrical compartment.

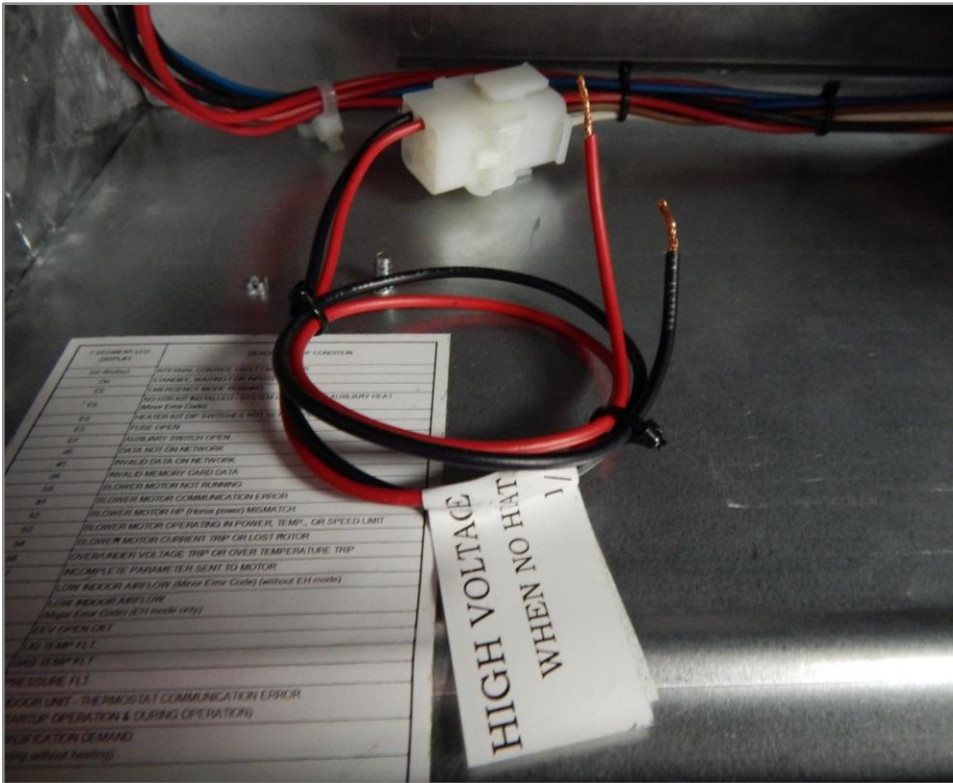

AHVE Installation

Low voltage connections

- Route control wires through the low voltage port and terminate in accordance with the wiring diagram.
- It is **STRONGLY** recommended that you do not connect multiple wires into a single terminal without mechanically twisting the tips together with a set of pliers.
- Minimum 18 AWG.

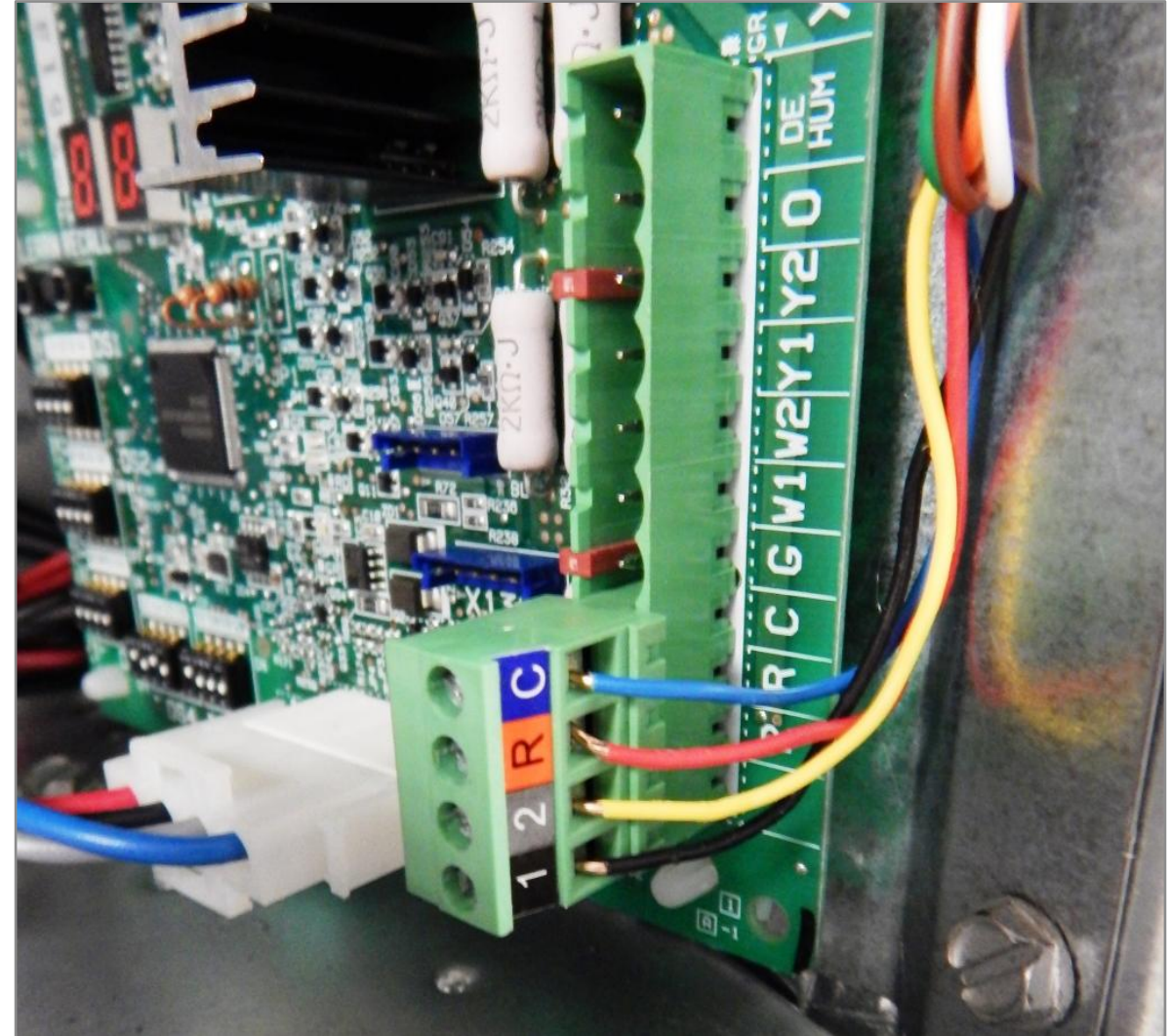

AHVE ECM orientation

- If the indoor unit is installed in the downflow position, loosen the motor mount and rotate motor as shown below.
- Be sure that the motor is oriented with the connections on the casing facing down.

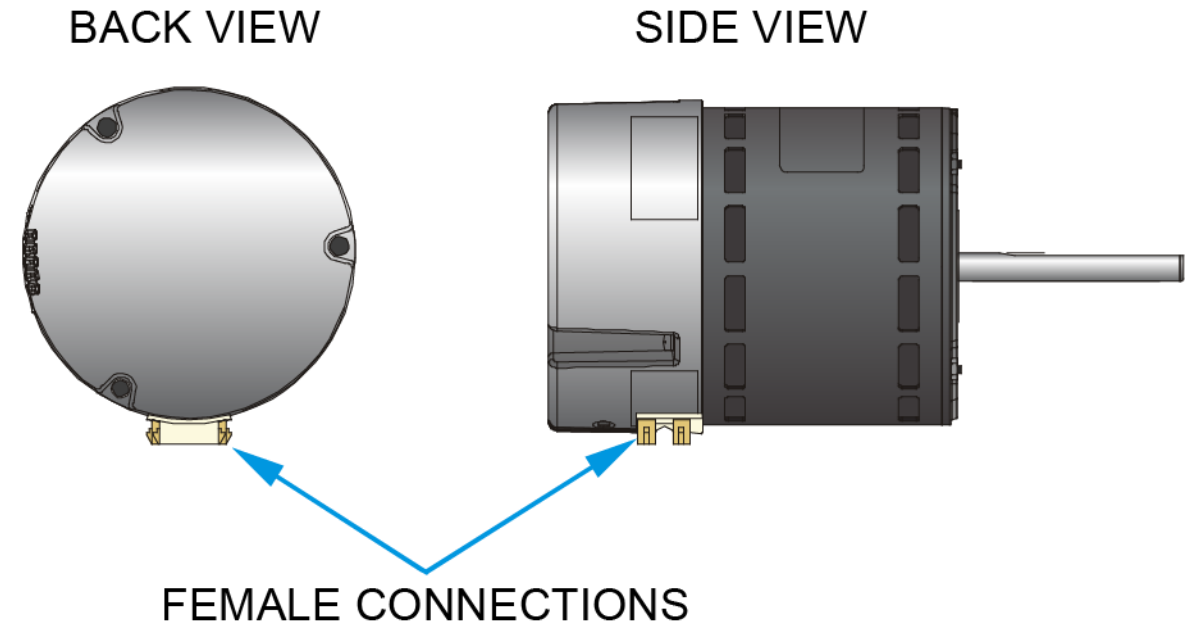

Agenda

Air Handler Installation and Coil Removal

Wiring Diagram and Plug ID

Dip Switches

Heater Kits

AHVE Wiring Diagram

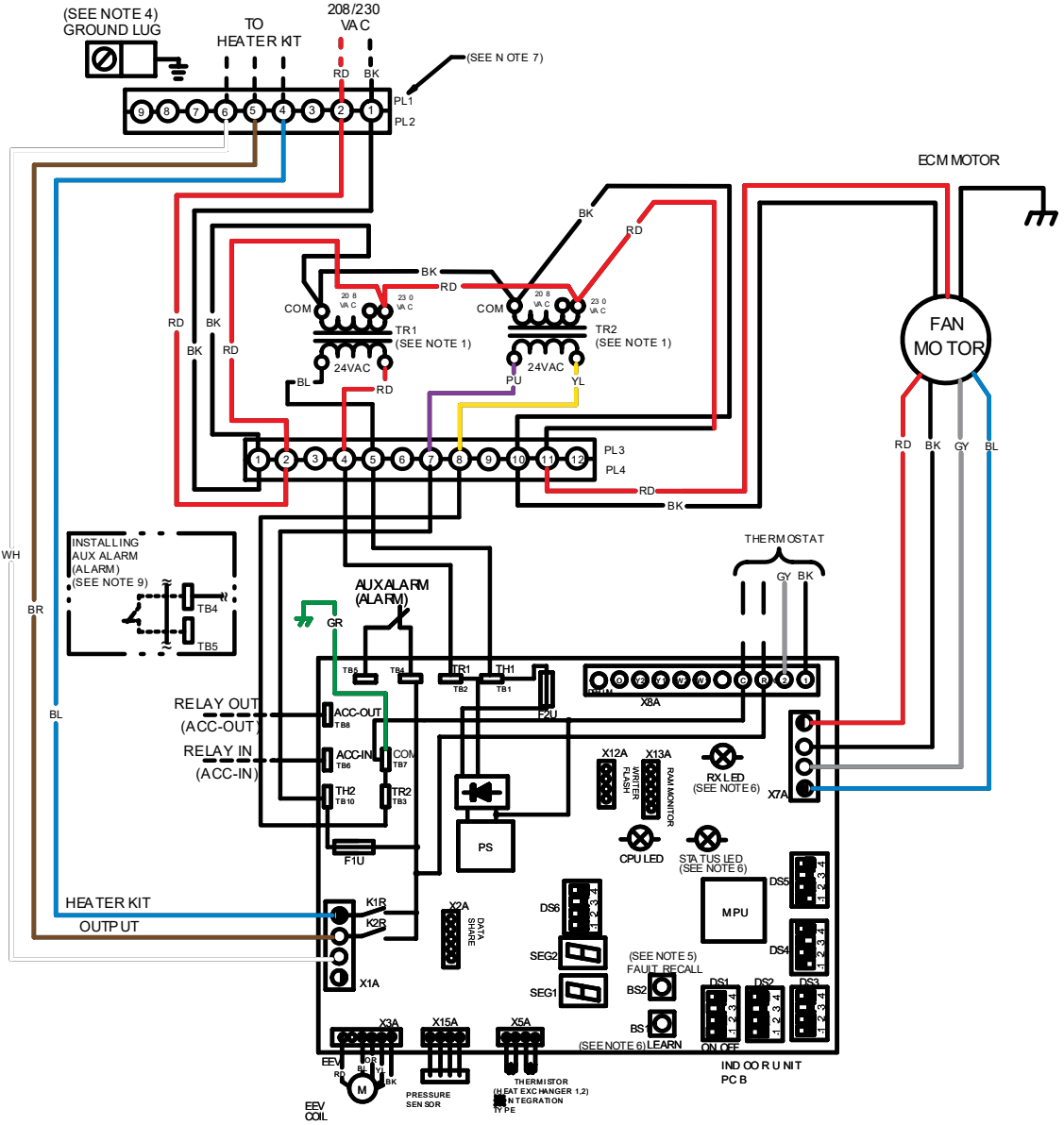

Agenda

Air Handler Installation and Coil Removal
Wiring Diagram and Plug ID

Dip Switches

Heater Kits

AHVE PCB

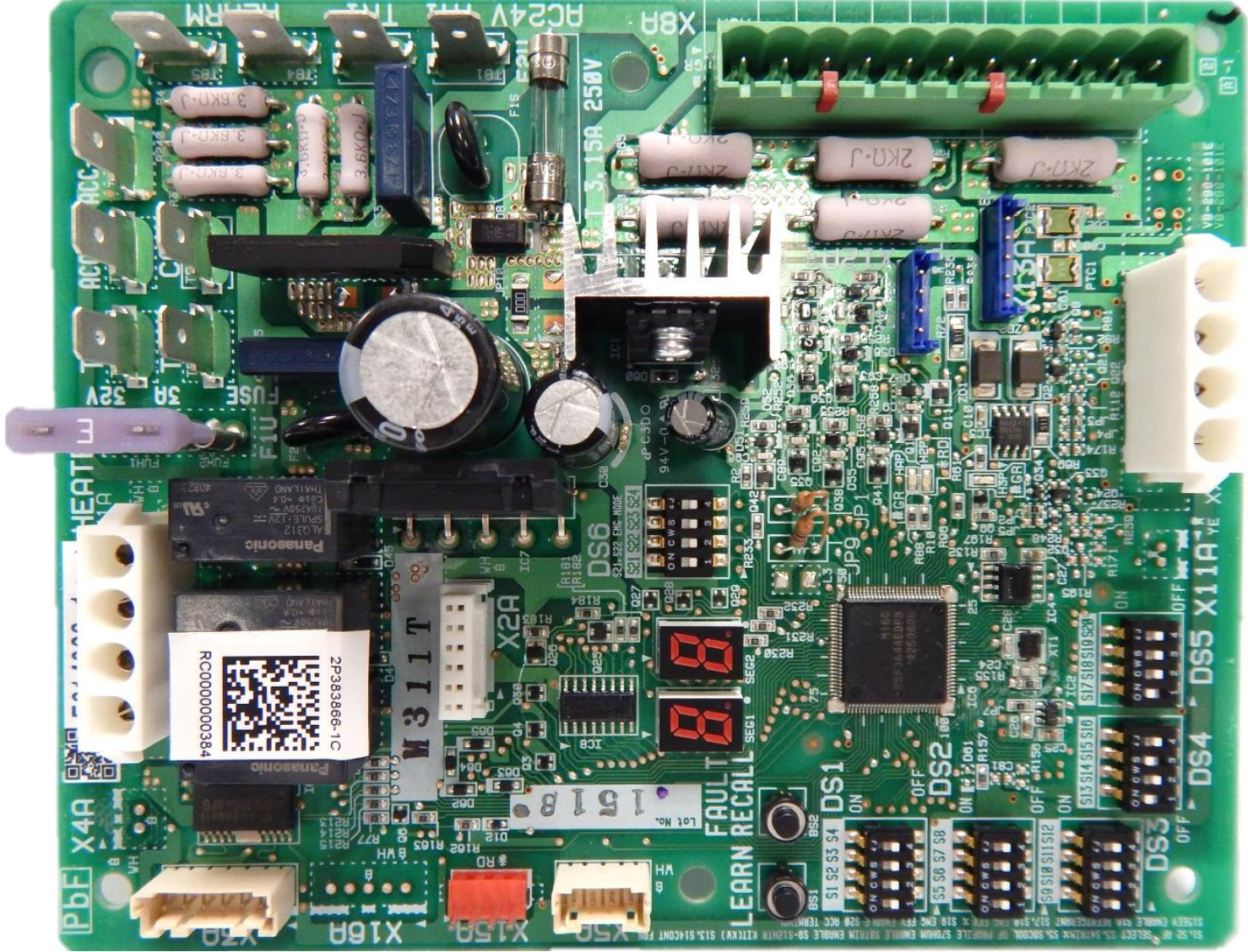

Dip Switches

AHVE PCB showing factory settings

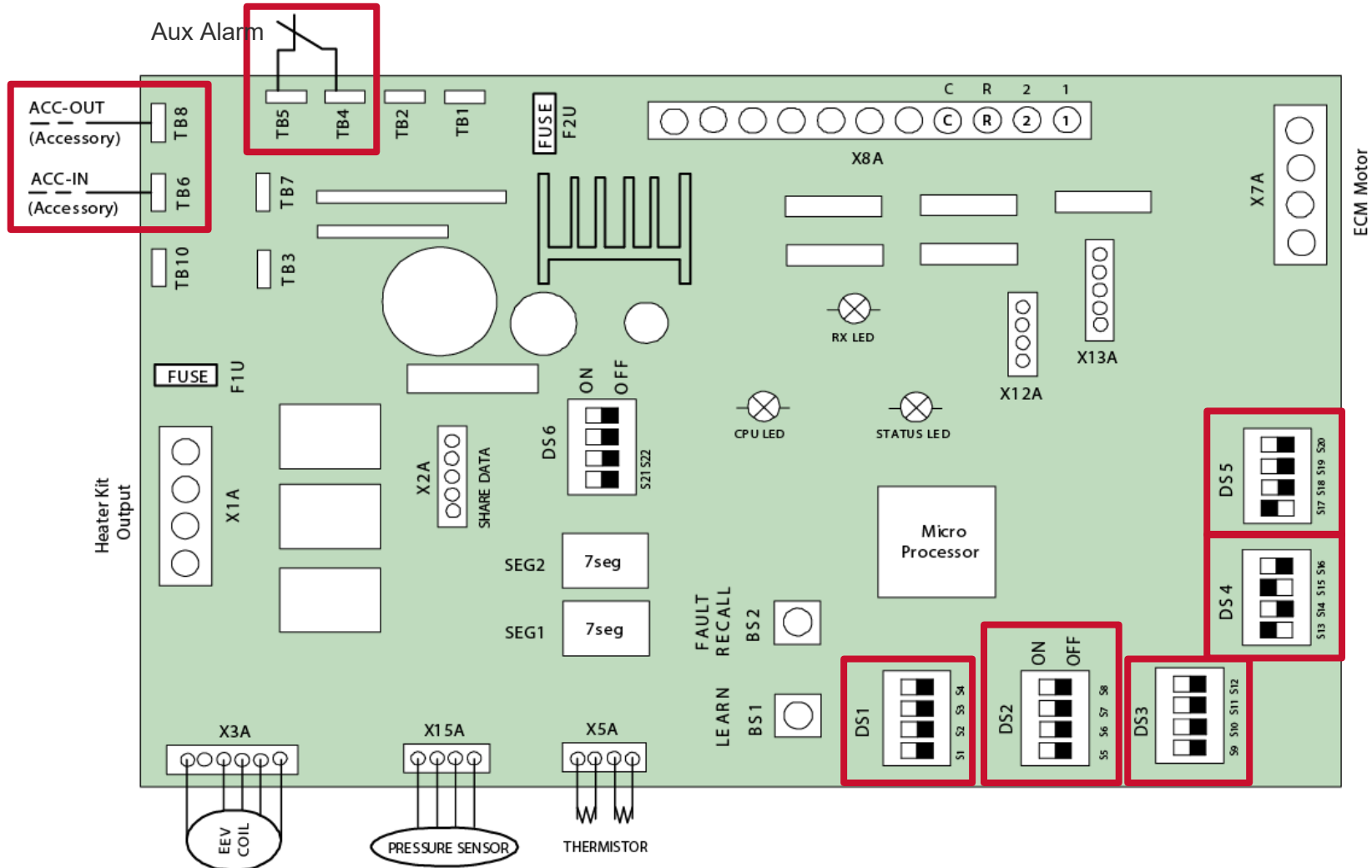

Onboard Auxiliary Alarm Switch

AHVE auxiliary alarm function

- Primarily used for a condensate switch input.
- The auxiliary alarm switch must be normally closed
 - Normally closed (NC) condensate switch opens when the water level in the evaporator coil base pan reaches an undesirable level.
- The control will respond by turning off the indoor blower, the outdoor unit and display the proper fault code (EEF).
- If the auxiliary alarm switch is detected closed for 30 seconds, normal operation resumes, and the error message is no longer displayed.

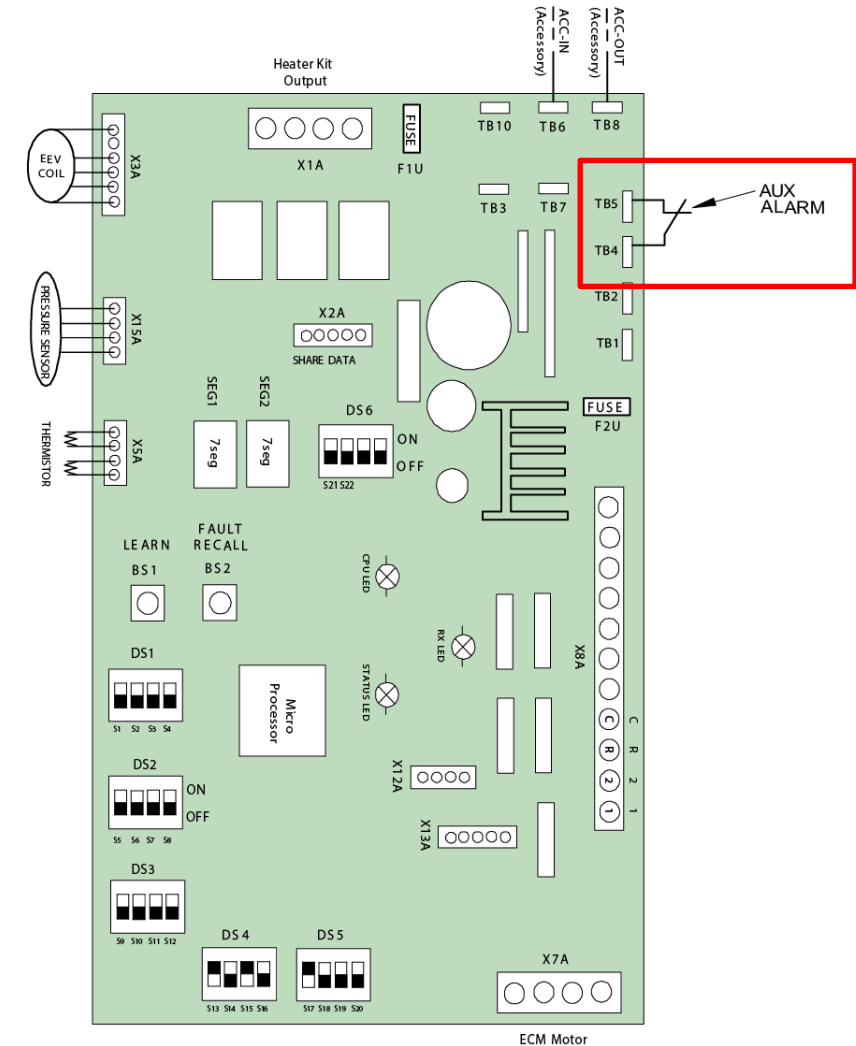

Agenda

Air Handler Installation and Coil Removal

Wiring Diagram and Plug ID

Dip Switches

Heater Kits

Heater Kits

Heater kit nomenclature

- AHVE specification sheet lists heater kit nomenclature for all AHVE models. (available with or without factory installed CB)

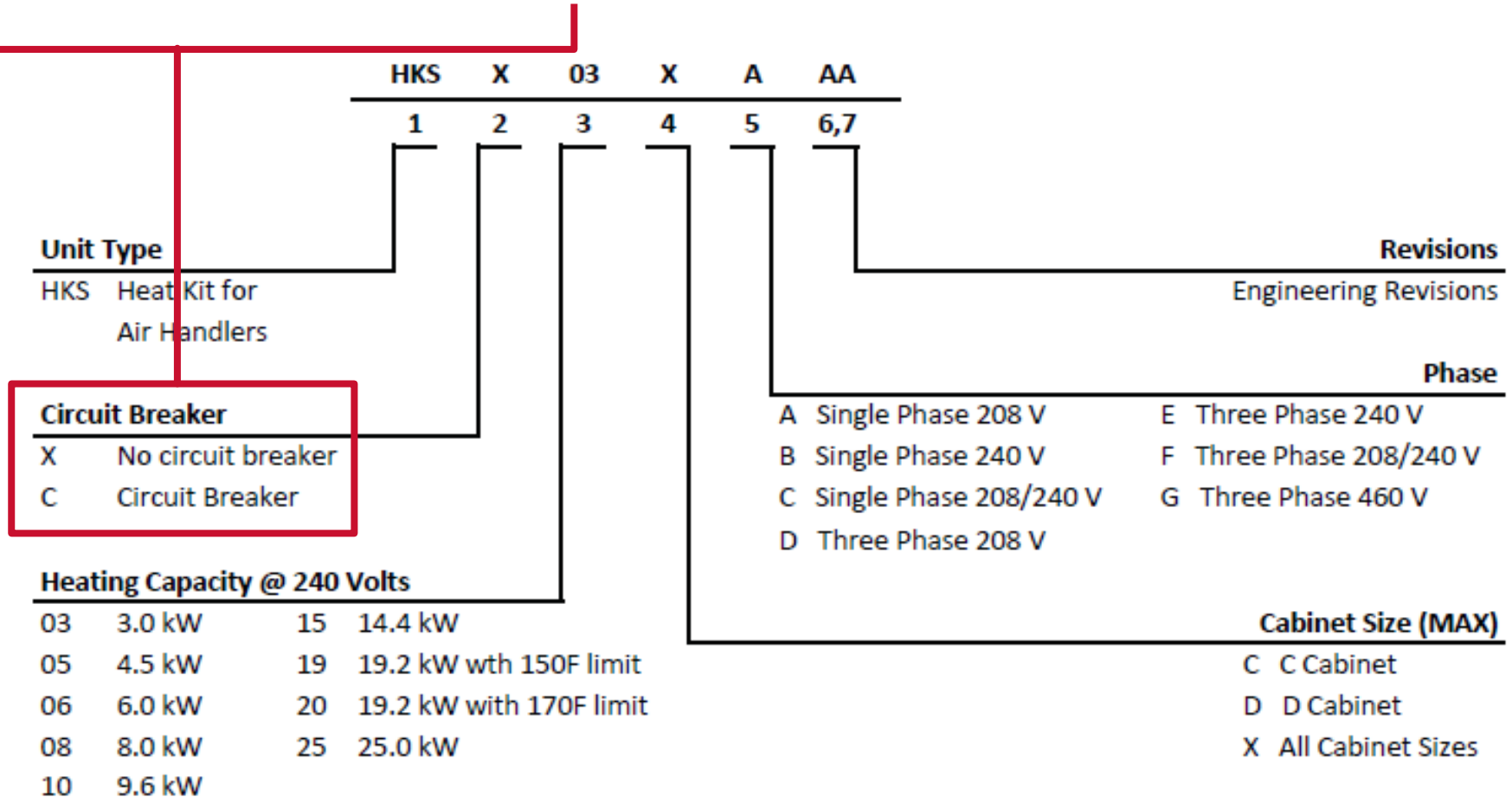

Heater Kits

1 Remove upper access panel



2 Remove (4) screws & cover plate

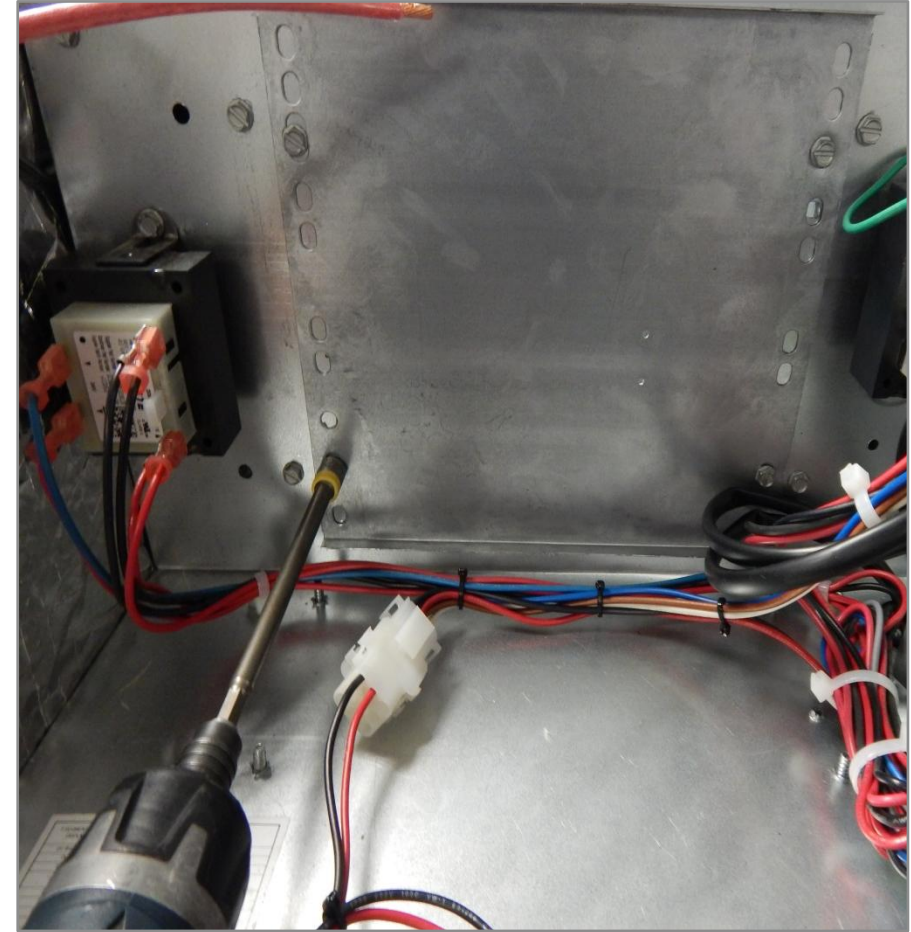

Heater Kits

3 Remove factory installed pigtail

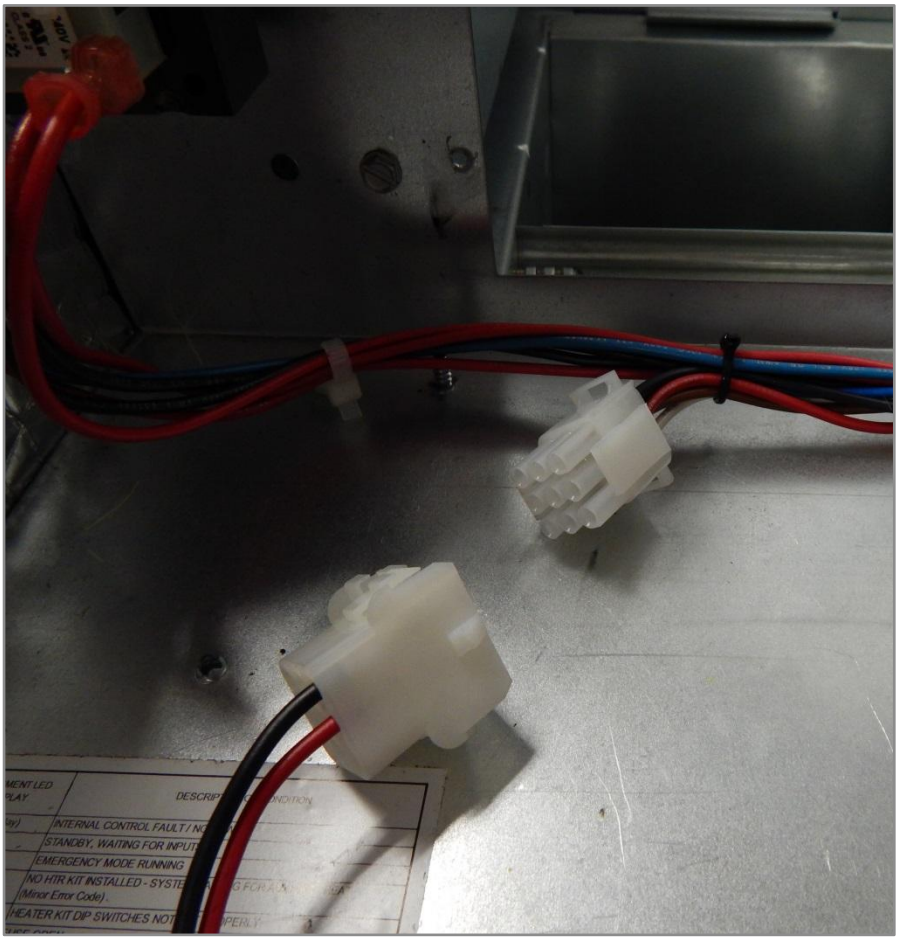

4 Install heater kit (arrows up)

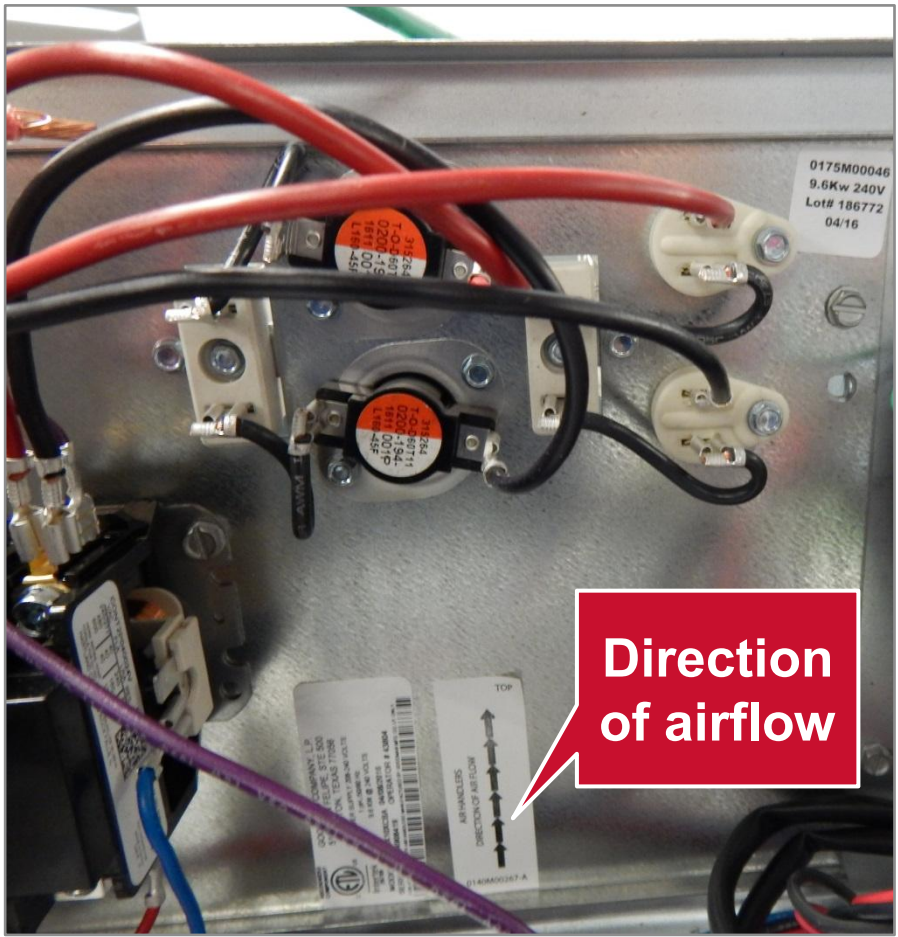

Heater Kits

5 Connect multi-pin connectors

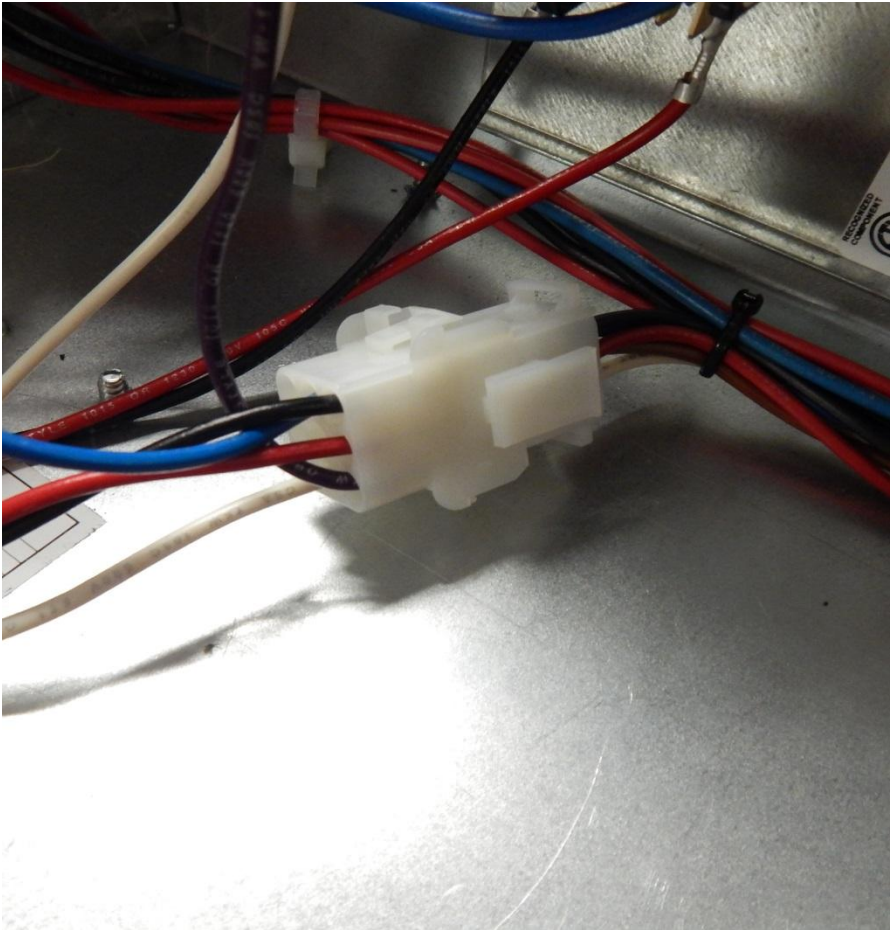

6 Install high voltage wires

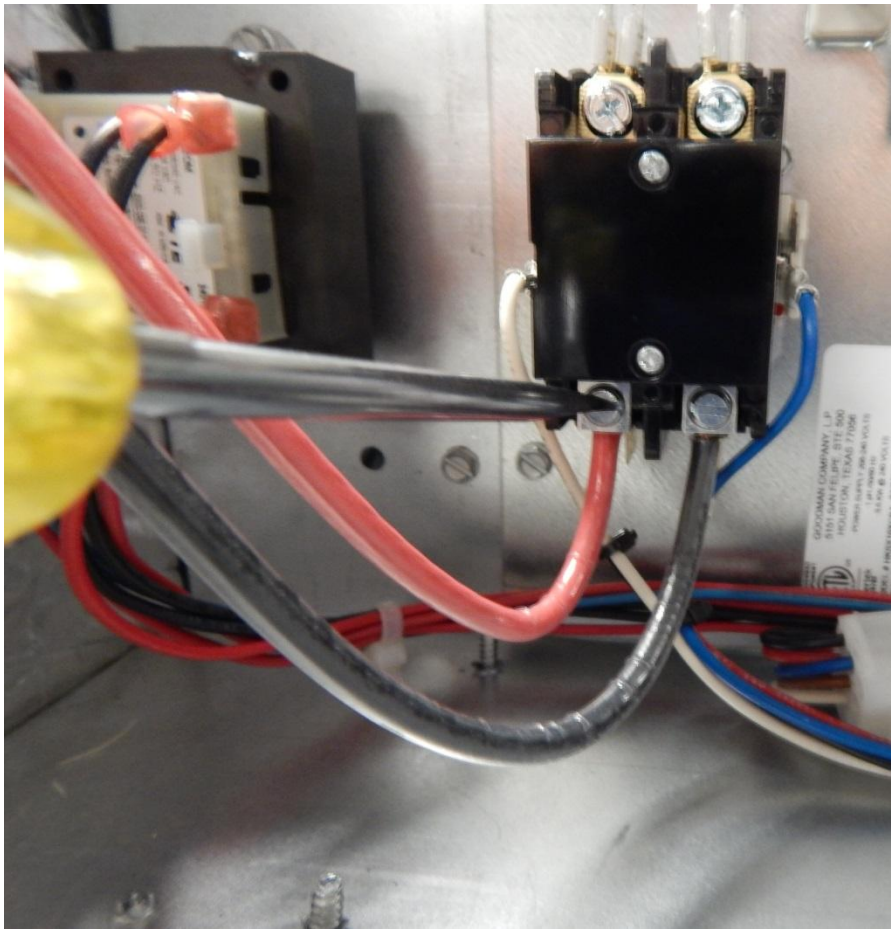

Heater Kits

7 Connect ground wire

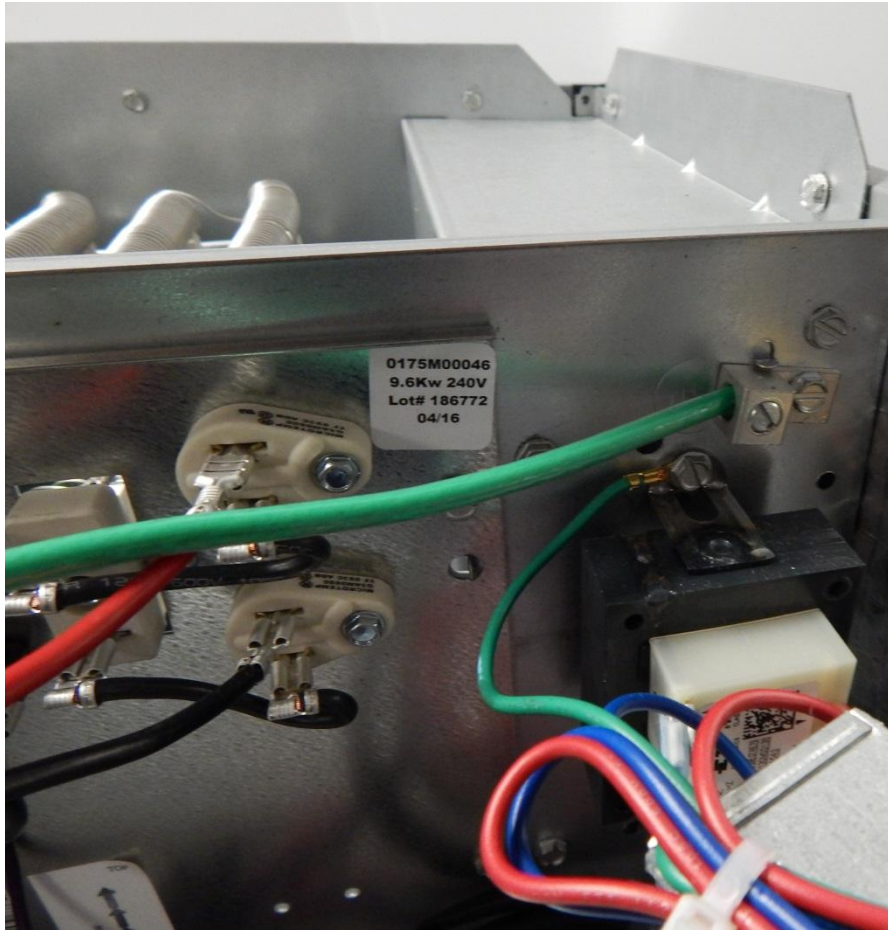

8 Secure upper access panel





Heater kit wiring diagram

- There are multiple options on the diagram sticker that is shipped with each heater kit.
- Mark an “X” on the wiring diagram according to the number of heater kit element rows installed and line out the remaining diagrams.

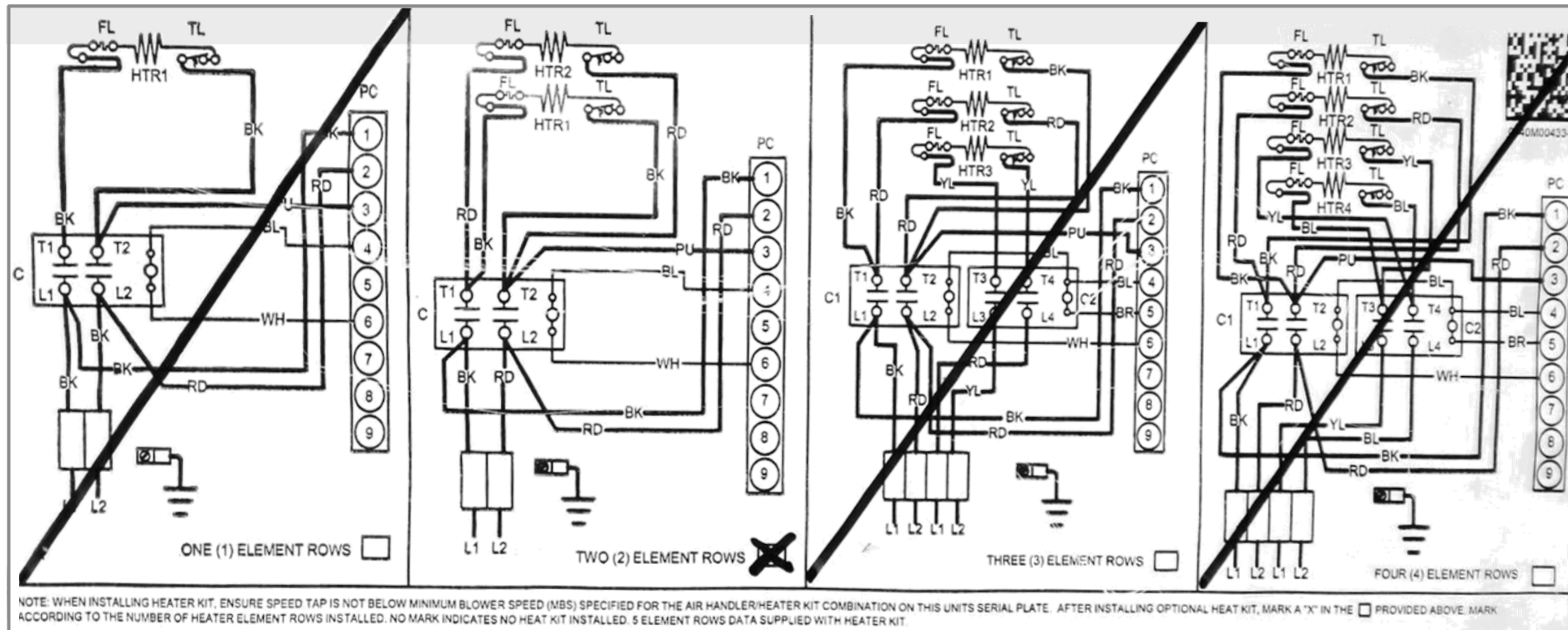

Heater Kits

Heater kit wiring diagram

Mark an “X” on the data sticker located on the outer panel of the air handler, to indicate the heater kit model installed.



AHVE48CP1400AA
1512076476
S274131

MODEL NO. AHVE48CP1400AA			SERIAL NO. 1512076476							
MOTOR		TEST EXTERNAL STATIC PRESSURE (INCHES) 0.3 MAXIMUM OUTLET TEMPERATURE 200 F 0 INCH CLEARANCE FROM CABINET, PLENUM AND DUCT, FOR INSTALLATION. LABEL PART NO. SR1436131								
AMP⁺	H/P									
3.9	1/2									
208/230		VOLTS		60 HERTZ						
1 PHASE										
WHEN INSTALLING ONE OF THE ACCESSORY HEAT KITS, PERMANENTLY IDENTIFY THE MODEL ON THIS PLATE.										
MARK HERE	HEATER KIT MODEL USED	M.B.S.	CIRCUIT 1			CIRCUIT 2			SINGLE POINT KIT	
			H.A.	M.C.A.	M.O.P.	H.A.	M.C.A.	M.O.P.	M.C.A.	M.O.P.
	NO HEAT KIT		0.0/0.0	4.9/4.9	15/15					
	HKS*03XC*		10.8/12.5	18/21	20/25					
	HKS*05XC*		17.3/20.0	27/30	30/30					
	HKS*06XC*		21.7/25.0	32/36	35/40					
	HKS*08XC*		28.9/33.3	41/47	45/50					
	<input checked="" type="checkbox"/> HKS*10XC*		34.7/40.0	48/55	50/60					

Heater Kits

11 Cut insulation behind cutout

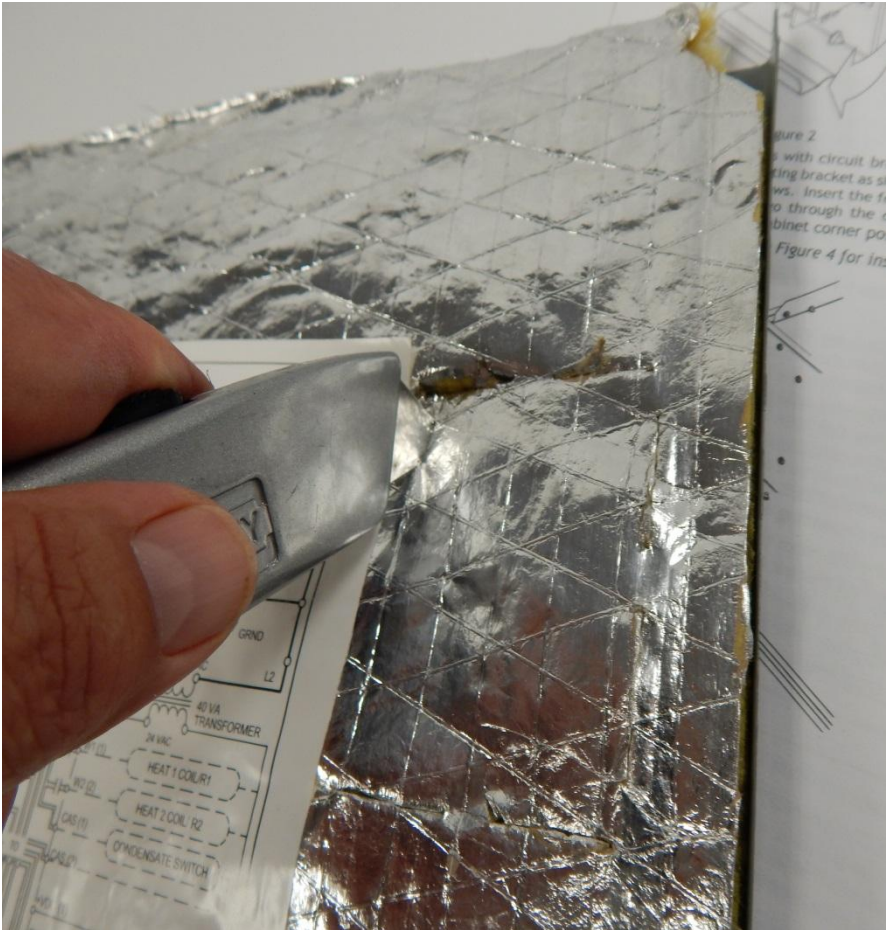

12 Replace cover panels on AHVE



Amana Smart Thermostat Installation & Commissioning

Technical Training Module TRC-9



Rest assured.

 It's an Amana® brand.

© 2022 Daikin Comfort Technologies North America, Inc.



© 2022 Daikin Comfort Technologies North America, Inc.

Amana® is a registered trademark of Maytag Corporation or its related companies and is used under license.
All rights reserved.



Agenda

Amana Smart Thermostat

System Configurations

Installing Amana Smart Thermostat

Commissioning Amana Smart Thermostat

Full Set-up

Dealer Navigation

Homeowner Navigation

Mobile Apps

Amana Smart Thermostat

- Premium control that provides optimal comfort.
- The high-resolution touch screen supports tactile-based interactions.
- Navigating to each screen is done by tapping an icon.
- Designed to regulate and communicate with HVAC equipment.
- The user will be able to control the indoor unit remotely through the Amana Home app.

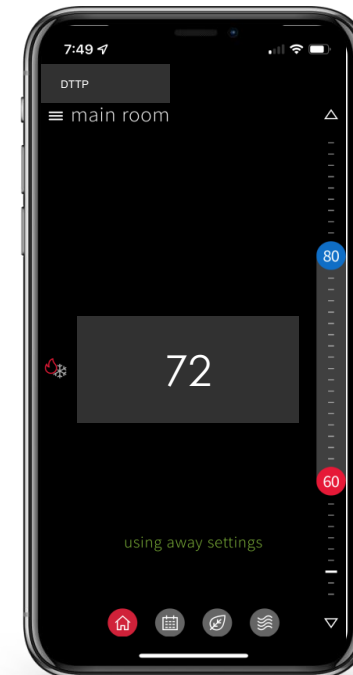
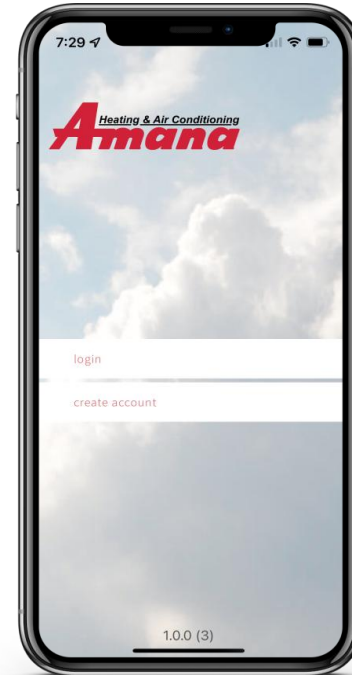
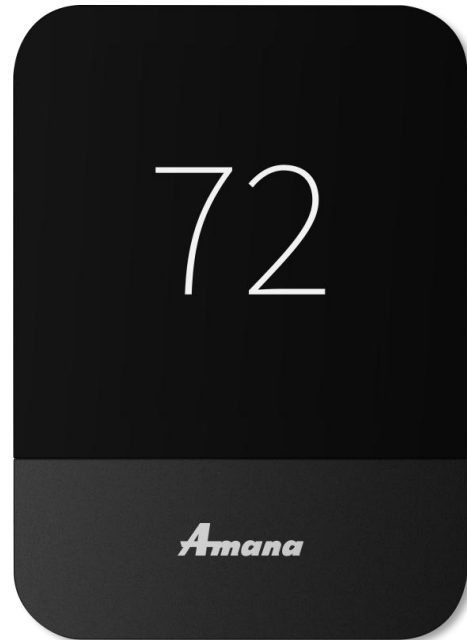

Amana Smart Thermostat

- Offers two-way communication when combined with:
 - Amana S-Series system; air conditioners and heat pumps, residential inverters; air conditioners and heat pumps, and two stage system; air conditioners and heat pumps.
- Serves as a cloud-connected hub and controller for communicating HVAC systems.

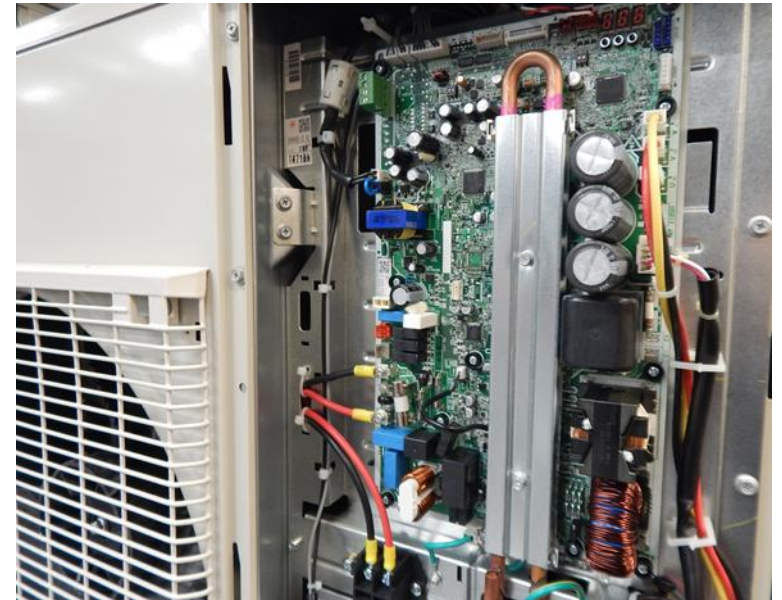

Amana Smart Thermostat - Messaging

- Amana Smart Thermostat's messaging updates, confirms, and informs about selections you make during set-up and operation.
- There are four types of messages:
 - Status
 - Alerts
 - Reminders and Prompts
 - Learn more/tips

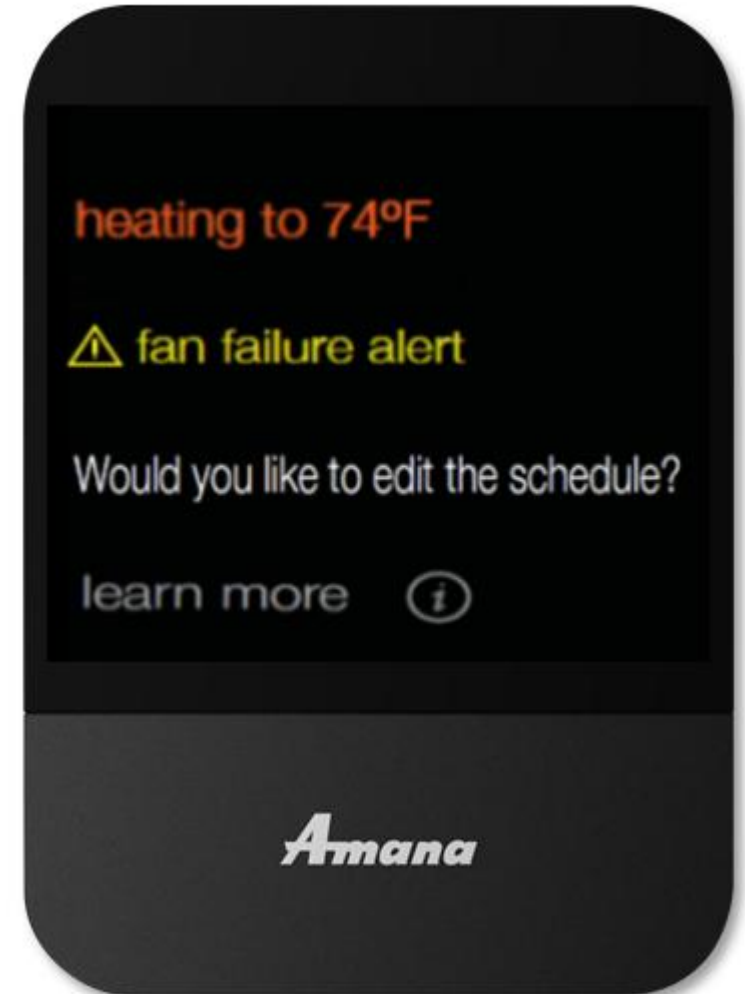

Note: Alerts have priority over all other messages in the system.

Amana Smart Thermostat - Quick Reference Card

- Quick reference cards are packaged with the thermostat to help answer questions during the installation and commissioning.

Dealers

Install the thermostat

Use the two included screws to secure the terminal plate to the wall. After connecting the wires, hook the top edge of the thermostat onto the holes on the top edge of the terminal plate. Rotate the thermostat down until it snaps into place. Once connected to power, follow the on-screen instructions.

Begin Setup
Use begin setup to customize settings and ensure the system is properly configured and ready for homeowners to use.



Terminal plate Screws Thermostat

Attach the thermostat to the terminal plate and snap into place



Get help at amana-hac.com/resources

Homeowners

Install the mobile app

Monitor and control your HVAC system from across the room, or from across the country.



Available on the App Store and Google Play.



amana-hac.com/app

Learn more about your smart thermostat

Find additional information about how your smart thermostat works and download the Homeowner Guide.



amana-hac.com/smart-thermostat

Scanning the bar code on the **bottom left** corner will link you to a website related to the title of the card. <https://amana-hac.com/resources>

Agenda

Amana Smart Thermostat

System Configurations

Installing Amana Smart Thermostat

Commissioning Amana Smart Thermostat

Full Set-up

Dealer Navigation

Homeowner Navigation

Mobile Apps

Valid System Configurations

Communicating indoor

- Air handler.
- Furnace.
- EEV coil.



Communicating outdoor

- Heat pump.
- Air Conditioning.



Agenda

Amana Smart Thermostat

System Configurations

Installing Amana Smart Thermostat

Commissioning Amana Smart Thermostat

Full Set-up

Dealer Navigation

Homeowner Navigation

Mobile Apps

Installing Amana Smart Thermostat



DO NOT Install the thermostat where it can be affected by:

- Drafts or dead spots behind doors and in corners.
- Hot or cold air from ducts or ceiling fans.
- Radiant heat from the sun or appliances.
- Concealed pipes and chimneys.
- Unheated (uncooled) areas such as an outside wall.



Installing Amana Smart Thermostat



- Mount the thermostat to be
 - Leveled.
 - Approximately 5' from the floor.
 - On an interior wall using the included screws.
- Attach the thermostat to the top of terminal plate and snap into place

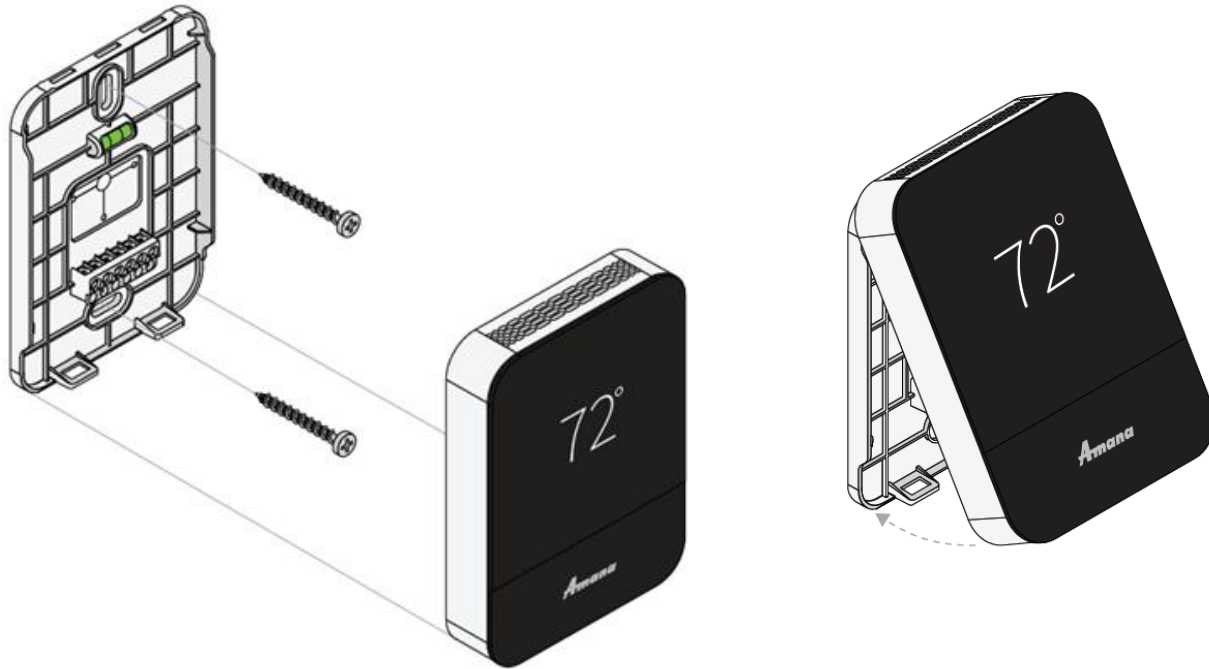

FLOOR

Wiring thermostat to communicating systems

- Maximum wire distance between the Amana Smart Thermostat and the indoor unit should not exceed **125 feet using 18 gauge wire**.
- **Check for proper voltage before and after wiring is installed.**
 - 0.6VDC between Data 1 and 2
- Wiring communicating indoor unit to communicating outdoor units.
 - Connect **1, 2, C and R** from the **Amana Smart Thermostat**, to **1, 2, C and R** at the **indoor unit**.
 - Connect wires **1 and 2** from the **indoor unit** to **1 and 2** at the **outdoor unit**.
- **Note:** The Amana Smart Thermostat is labeled **1, 2, C, R**. **If wired incorrectly, you will receive a communication error, or your equipment may not be recognized and displayed.**

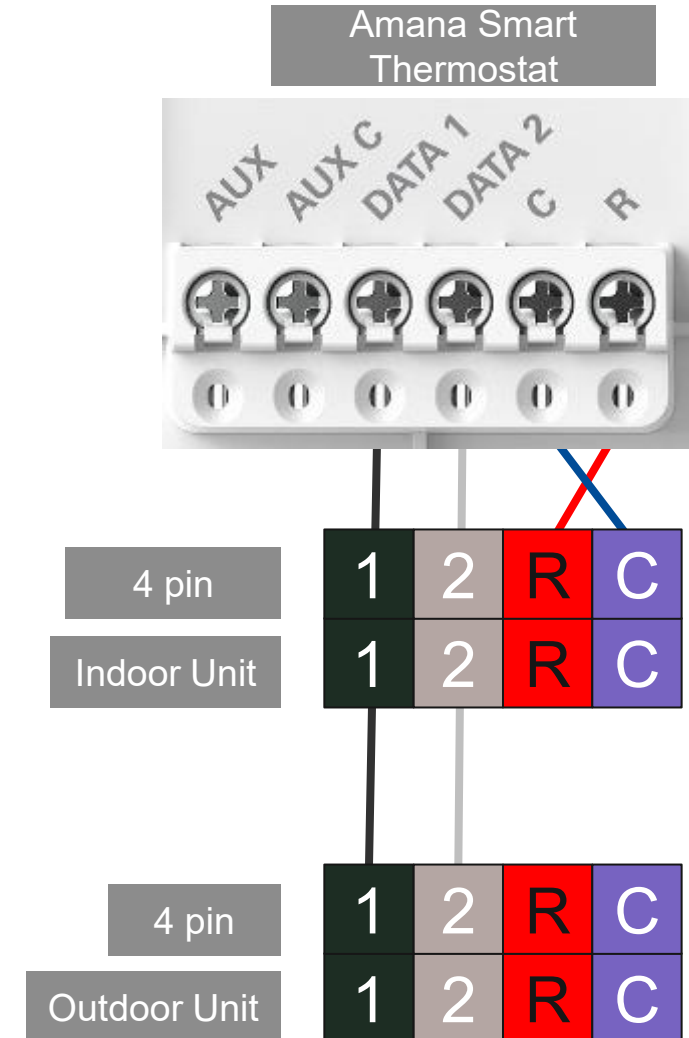

Aux Wiring

- The thermostats Aux outputs are dry contacts that close the connection to turn on the Aux equipment.
- A 24V AC control signal must be routed through one of the aux contacts of the thermostat.

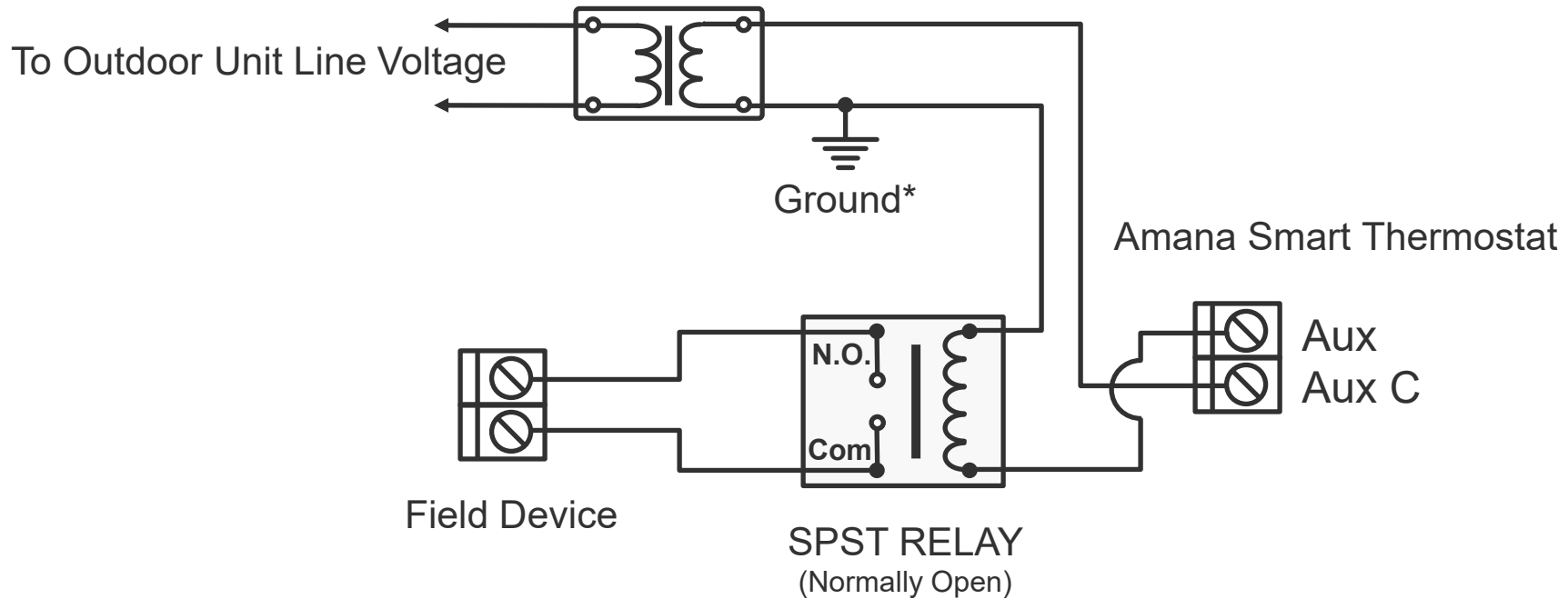

*The terminals are selected in the Amana Smart Thermostat installer wizard.

Note: It is recommended to use a minimum of 18-gauge wire. Maximum operating length of wire is 125 ft.

Commissioning Amana Smart Thermostat



- Start-up screen is displayed upon powering the thermostat.
- The welcome screen displays preferences to choose from.
- Version of the thermostat is displayed on the learn more screen.
- Selecting setup options allows you to factory reset the thermostat.

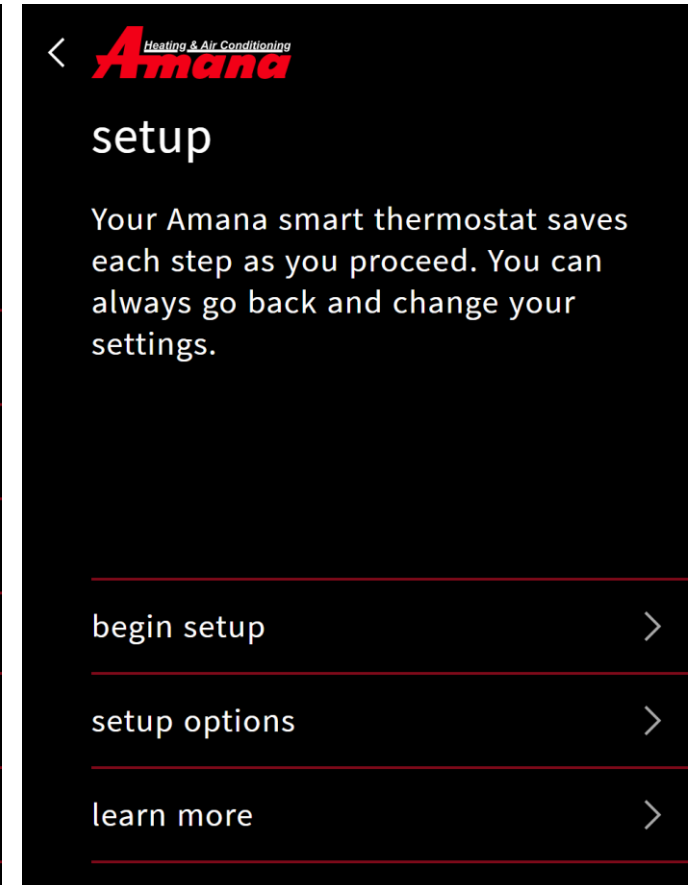
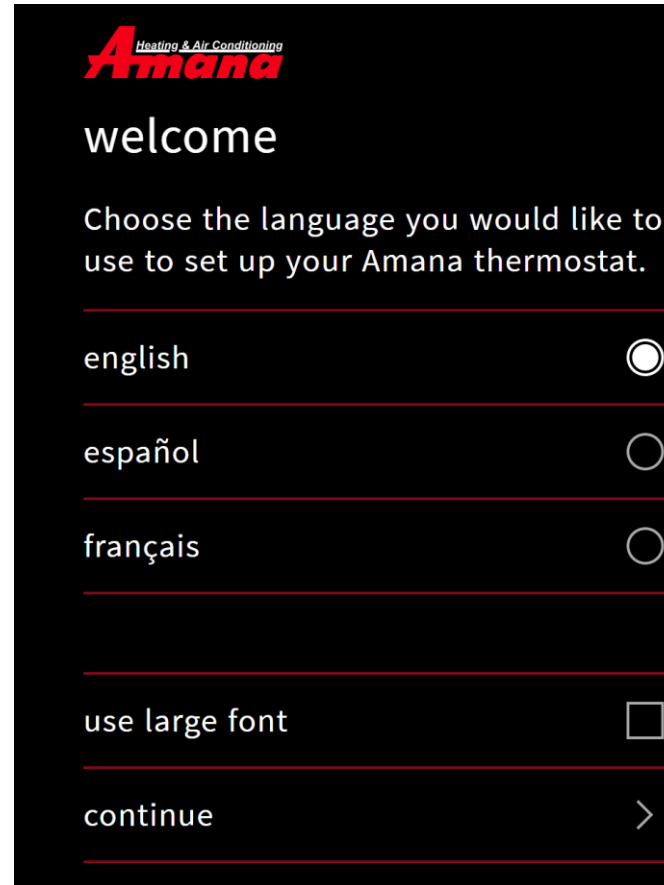

Commissioning Amana Smart Thermostat

- Begin set-up: walks installers through the entire commissioning process to ensure the system is configured properly and ready for the homeowner to use.
 - Enables random access to any setting.
 - Remembers settings as they are entered.
 - Individual may stop and restart as needed.
- The screens are populated based on the model numbers of the equipment, matched to a database of device configuration settings.

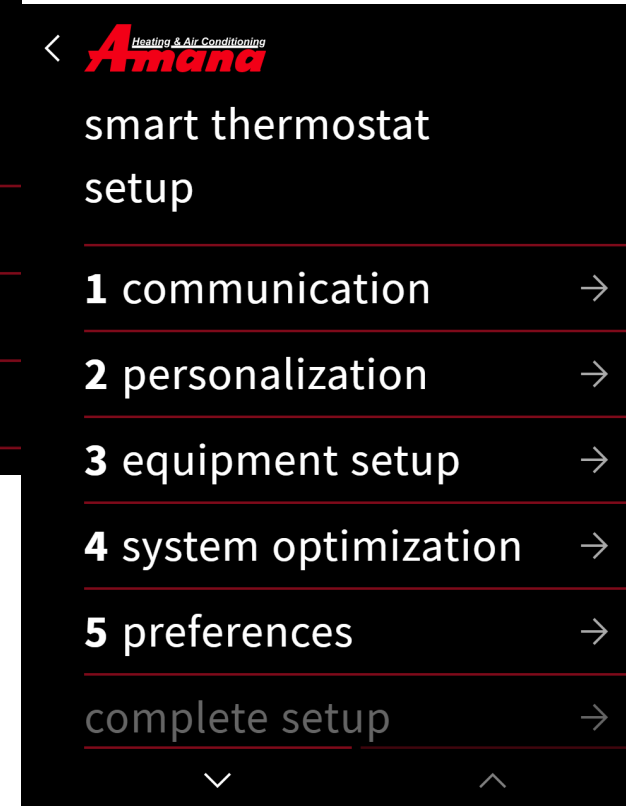
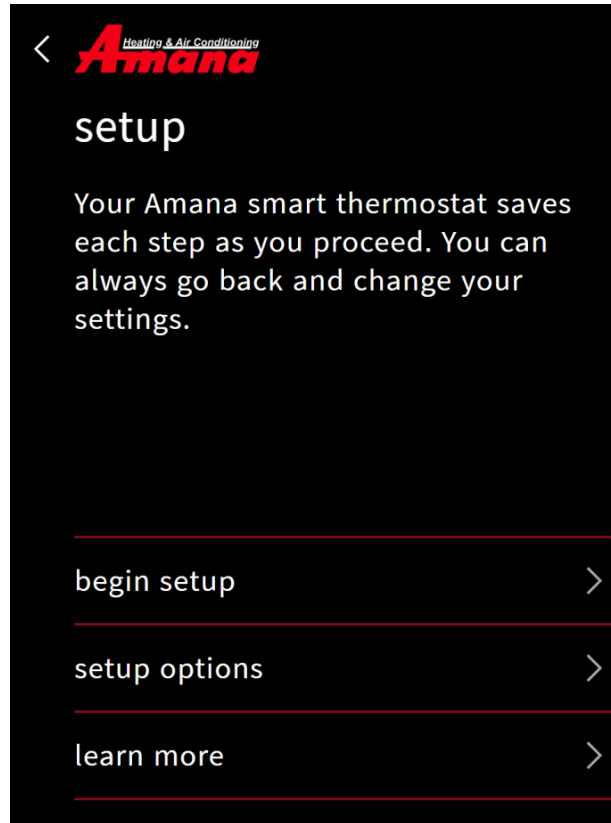

Agenda

Amana Smart Thermostat

System Configurations

Installing Amana Smart Thermostat

Commissioning Amana Smart Thermostat

Full Set-up

Dealer Navigation

Homeowner Navigation

Mobile Apps



Start-up

- Tapping begin set-up starts the five step set-up process:
 - Communication.
 - Personalization.
 - Equipment Set-up.
 - System Optimization.
 - Preferences.

Note: All steps must be completed and reviewed before completing set-up to ensure the system is configured properly and ready for the homeowner to use.

For detailed menu settings:

<https://amana-hac.com/resources>

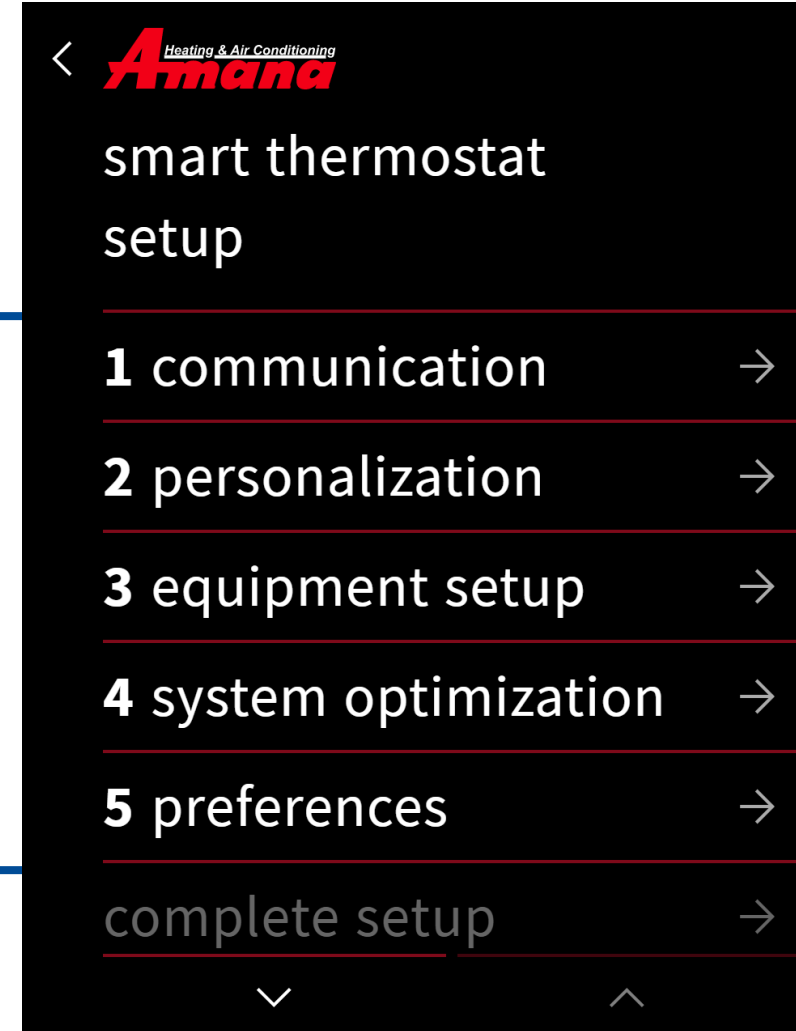

Full Set-up

Step 1 - Communication

- Configures **Communication Networks**.
- Select home Wi-Fi to search for networks.
- With **Wi-Fi configured**, the system can check the software version and update software to the **latest** version **automatically**.

Note:

- A warning is generated if the router is not password protected.
 - Compatible with 5Ghz routers which supports 2.4Ghz
- Equipment type displays the equipment selected on start up.

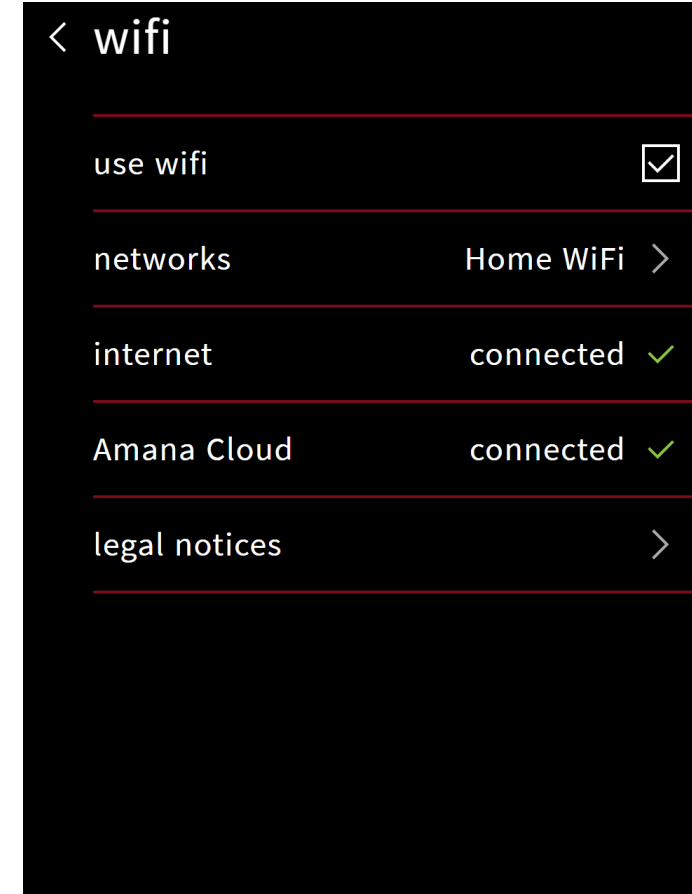
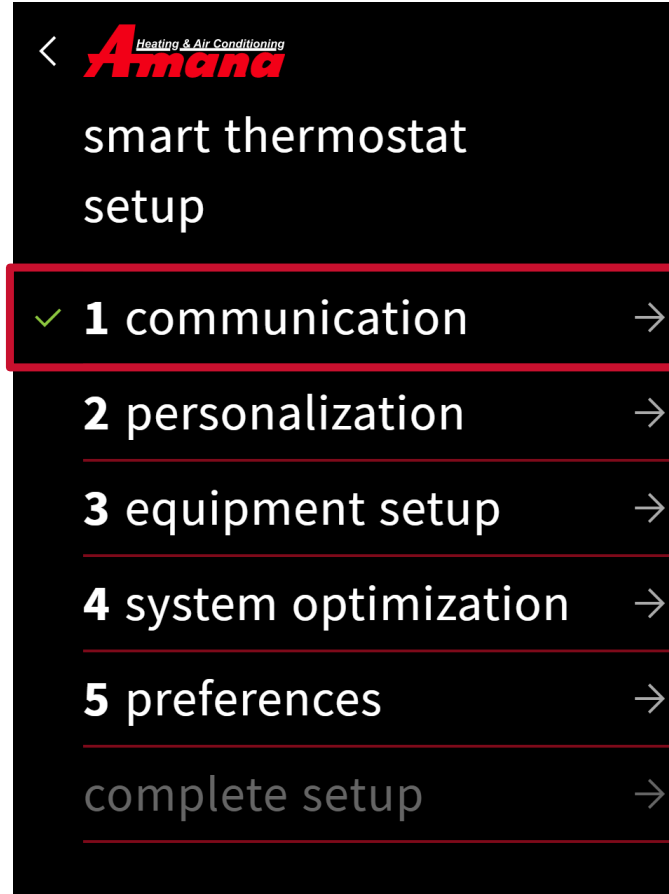



Step 2 - Personalization

- Tapping the **personalization tab** allows you to edit default information.
- Personalization displays:
 - Language.
 - Large font selection.
 - Date & Time.
 - If Wi-Fi is connected, date & time are set automatically.
 - Thermostat Name.
 - Degree Units.

Note: A green check mark appears next to items reviewed from the set-up menu.

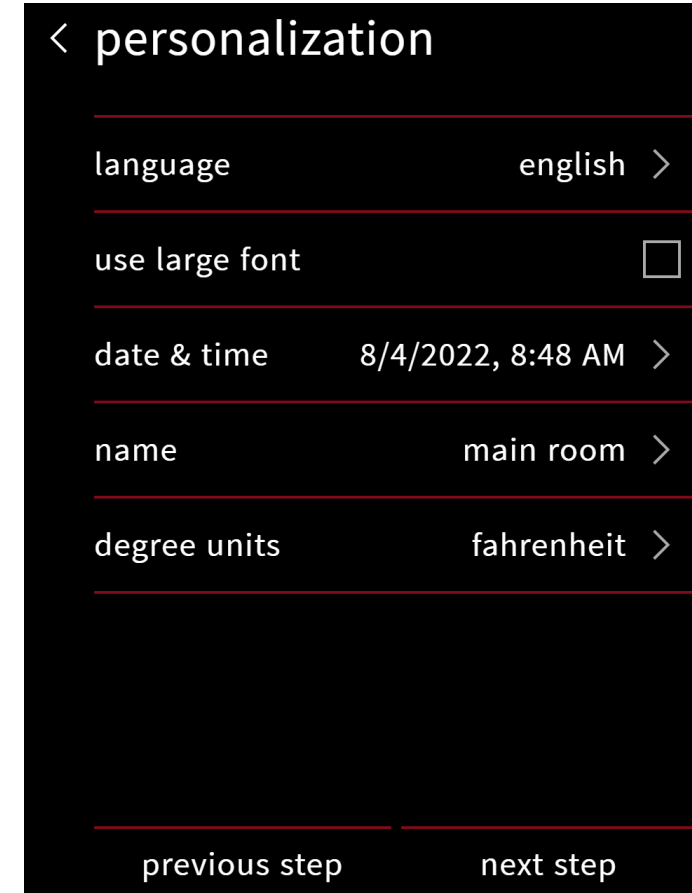
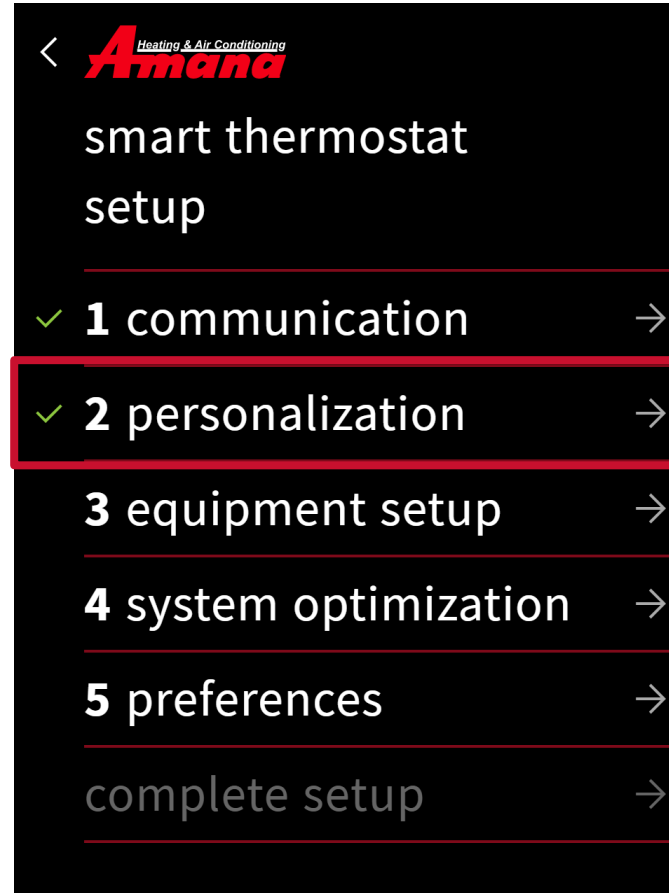

Step 3 - Equipment Set-up

- Displays equipment found by searching the communication network, or by adding/removing equipment and accessories from the preset list.
- The unit that is identified determines the list of configurations that will be displayed
 - View unit Specifications.
 - Configure
 - Cool settings
 - Heat Settings
 - Heat Pump Settings
 - Aux alarm
 - Heater Kit

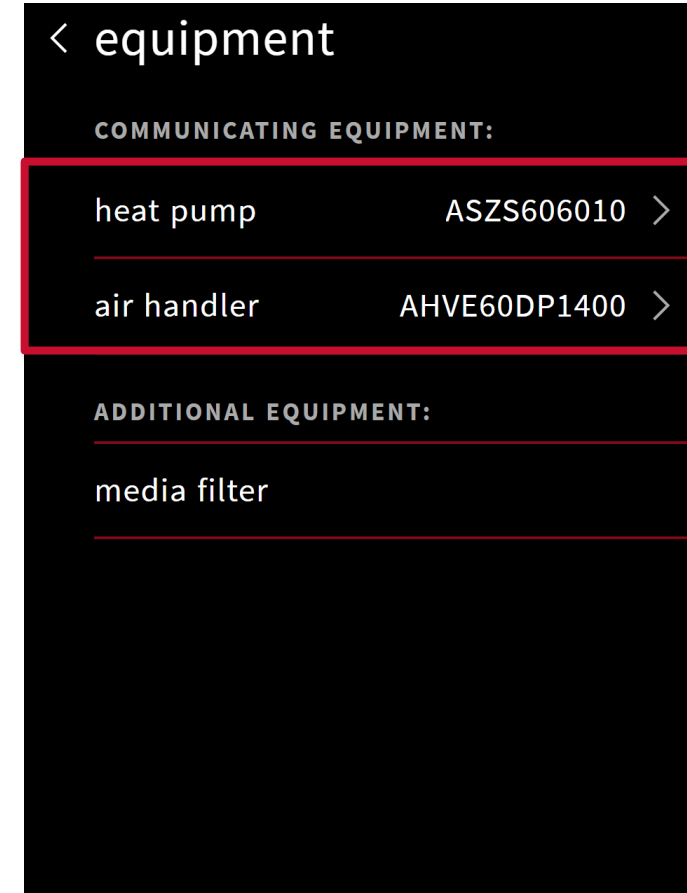
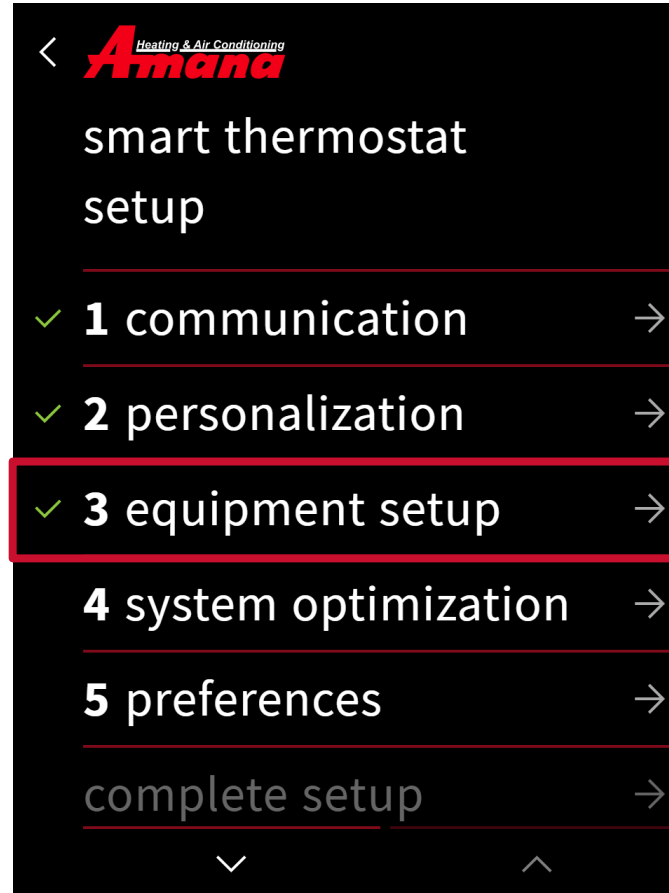

<https://amana-hac.com/resources>

Amana Smart Thermostat

Added equipment

- The Amana Smart Thermostat is compatible with multiple accessories.
 - Humidifier
 - Dehumidifier
 - You can Install the humidifier and dehumidifier by using aux
 - Recommend using an isolation relay between auxiliary device and thermostat.
 - UV Bulb
 - Electronic Filter
 - HEPA filter
 - EWC Zone Board.

Humidifier



Dehumidifier



EWC Zone Board

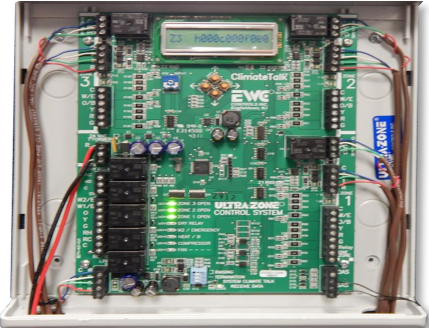

Full Set-up

Add equipment – auxiliary heat

- Selecting add equipment will allow you to configure an auxiliary heat source.

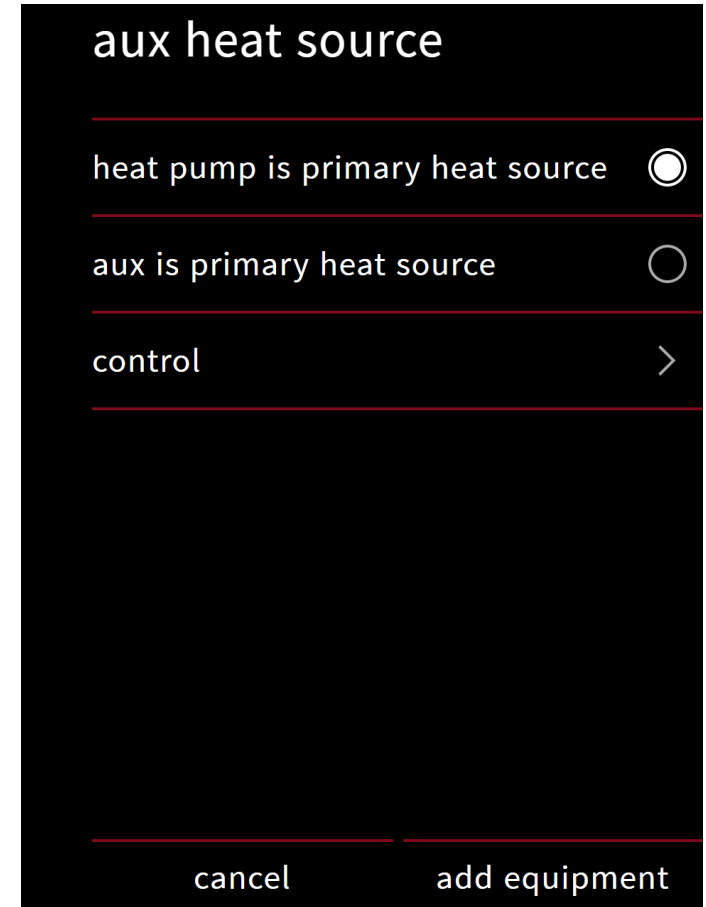
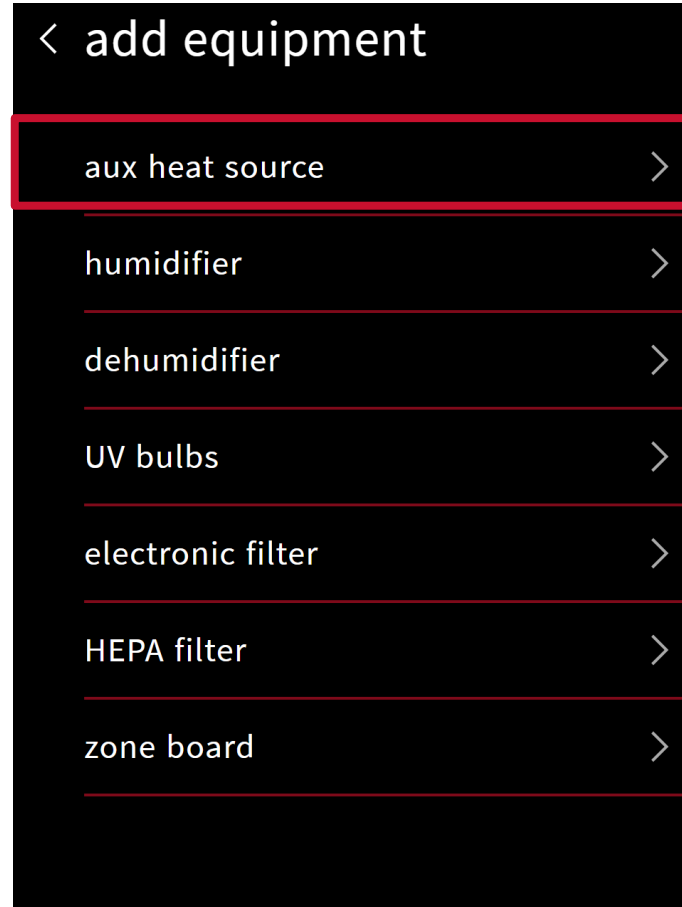
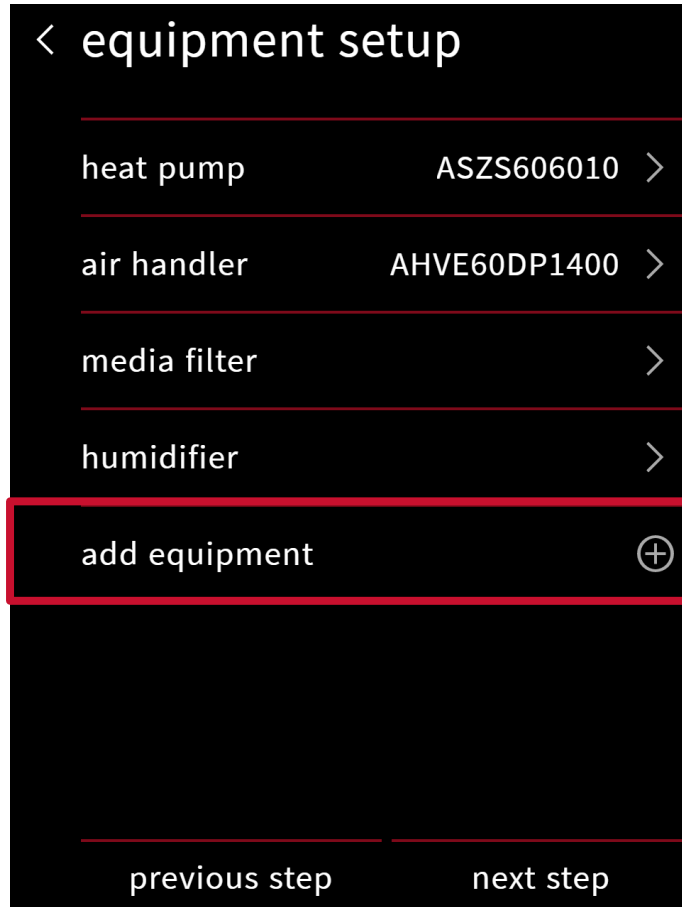

***Aux heat source is the only control option for an AC only outdoor unit.**

Aux Heat Setup on Amana Smart Thermostat

Secondary heat settings

- The control section will allow you to adjust settings such as lockouts and secondary heat activation temperature.

*** Emergency Heat mode will appear as a system mode when connected to heat pump units and can be used to directly turn on the aux heat source if enabled.**

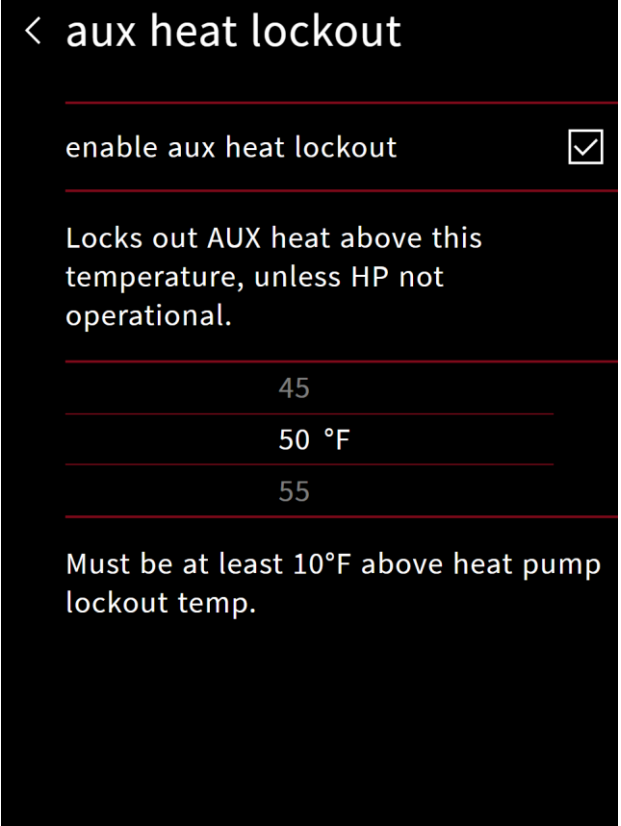
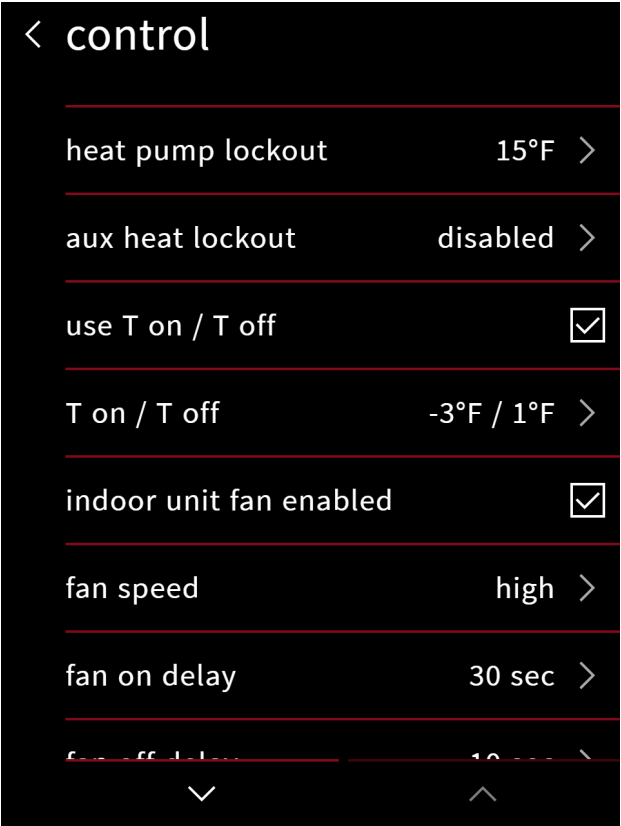

T on/T off Control

- T on and T off provide an alternative control method to having the main AC/heat pump control the aux heat source using its PI control algorithm.
 - T on/T off is the only control option for aux heat with AC- only outdoor units
 - If the indoor unit is a gas furnace, or is an air handler with a heater strip, these heat sources will be controlled around the heat setpoint by the demand-based PI control algorithm.
 - When T on/T off is selected, the aux heat source will be controlled independently using these settings.

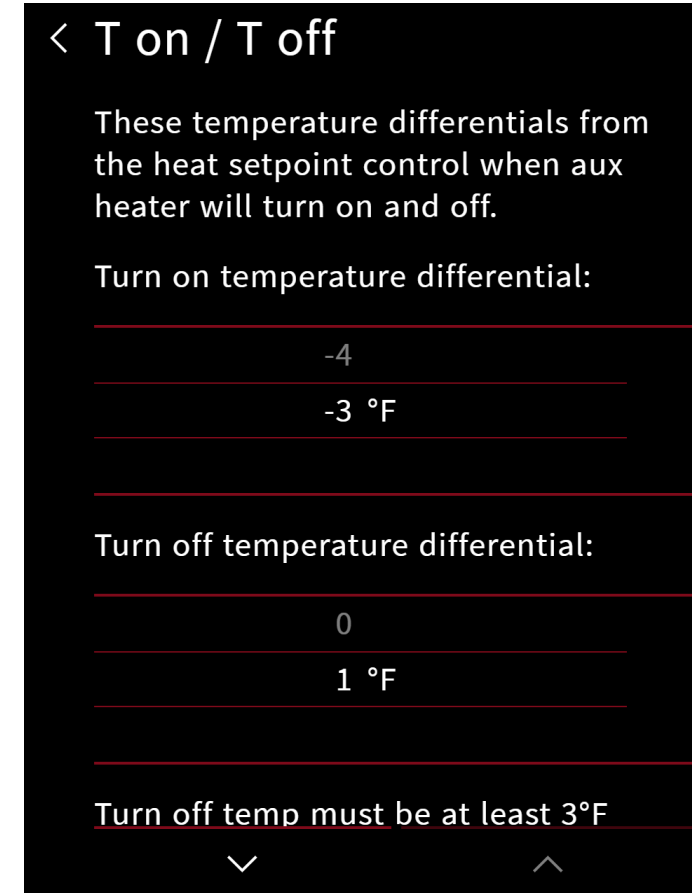
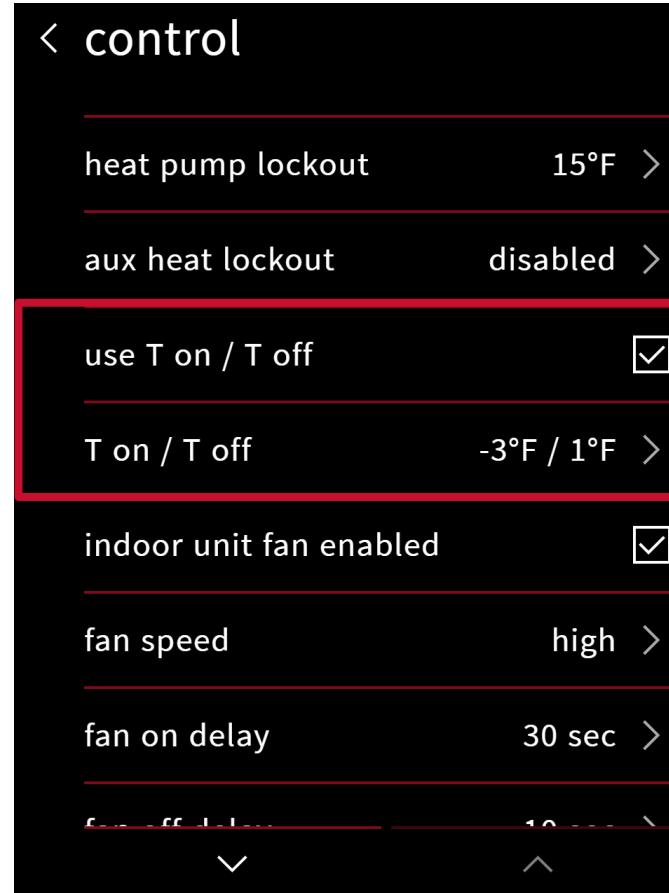

Step 4 – system optimization

- System optimization displays:
 - System test.
 - **Inverters only.**
 - Charge mode.
 - **Inverters only.**
 - Optional test.
 - Error history.
 - Logs alerts with an error code.
 - **White = not critical**
 - **Yellow = critical**
 - Calibration.

Thermostat must be in OFF mode.

 - **Wait 30 minutes before calibration for the thermostat to equalize.**
 - Status.

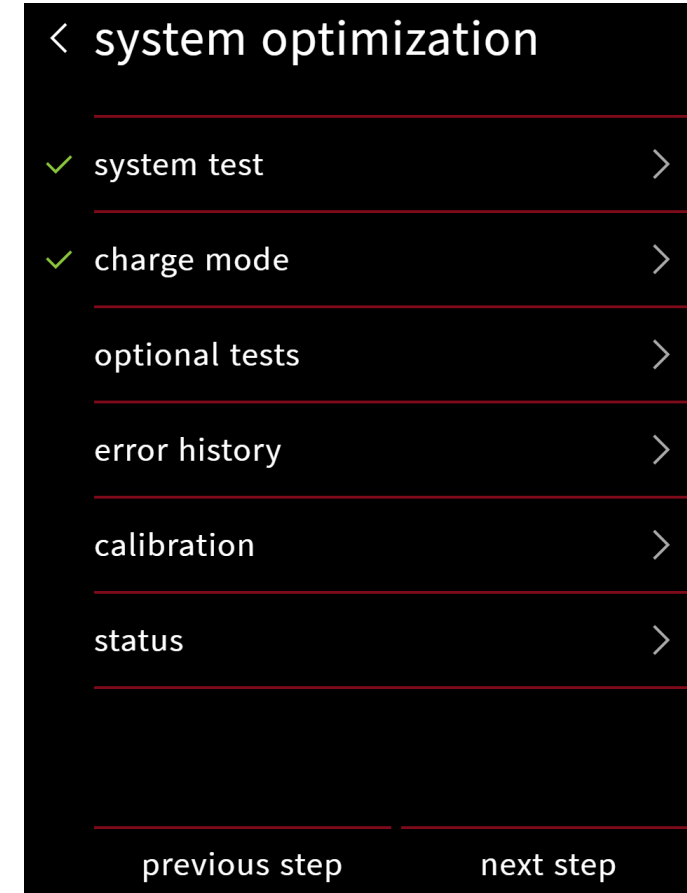
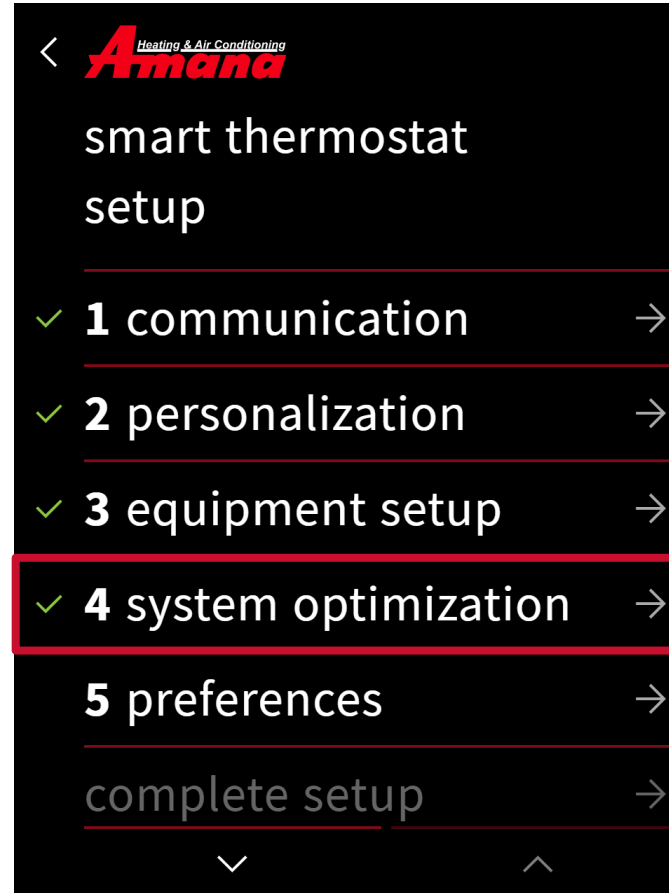

System test

- Running system test is required for the inverter units before proceeding to complete set-up.
 - You cannot stop this test.
- To proceed through the set-up process, the system test needs to be completed without any errors.
- When the tests are completed, the run test screen is displayed.
 - System test is complete only when display code E11 notice clears from the seven segment LED display on the heat pump or air conditioner.

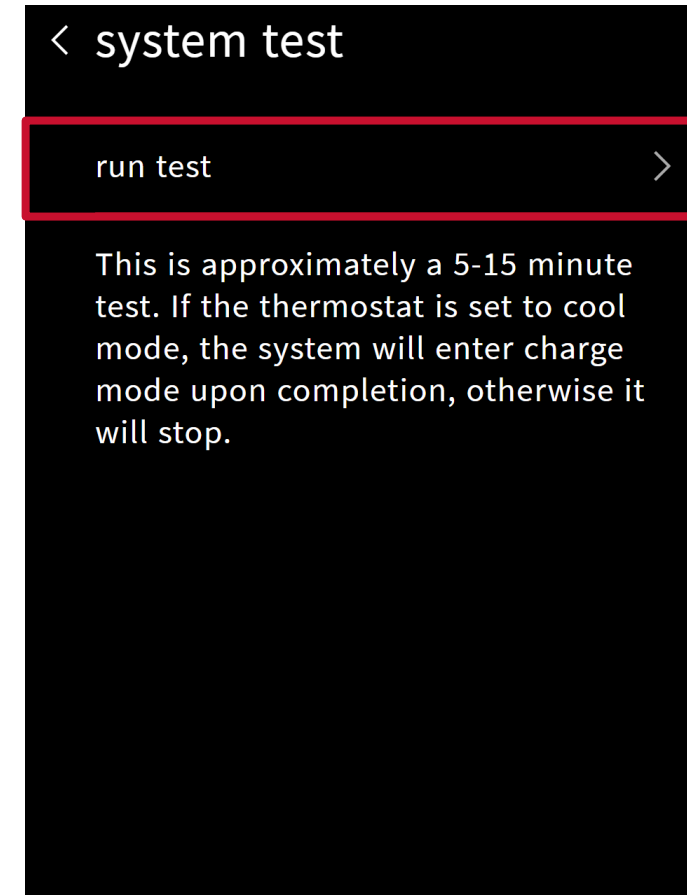
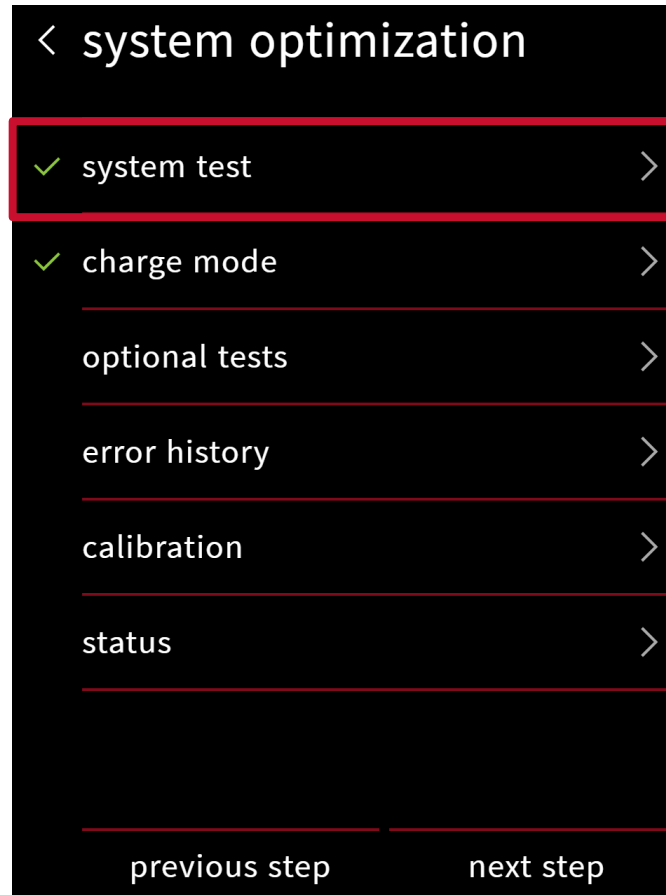



Optional tests

- Each optional test has a short description.
- Optional tests display a stop test button while test is running.

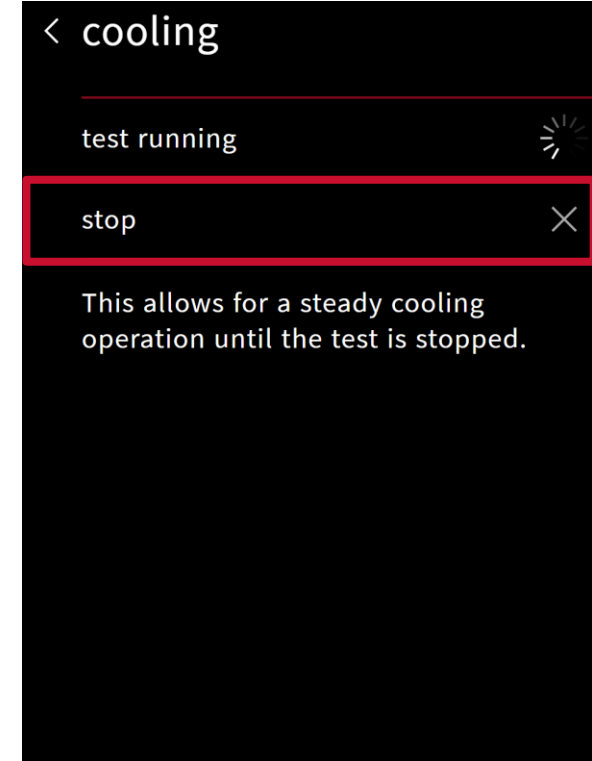
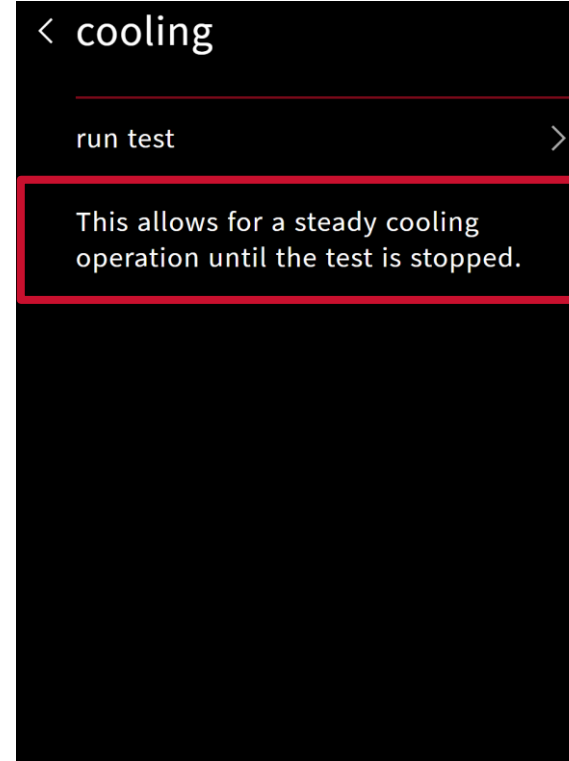

Note: Thermostat will only display tests that the system can perform.

Full Set-up

Status

- The status menu displays data pertaining to the selected equipment.
- The scrollable list can be accessed any time by returning to the installer set-up screen.

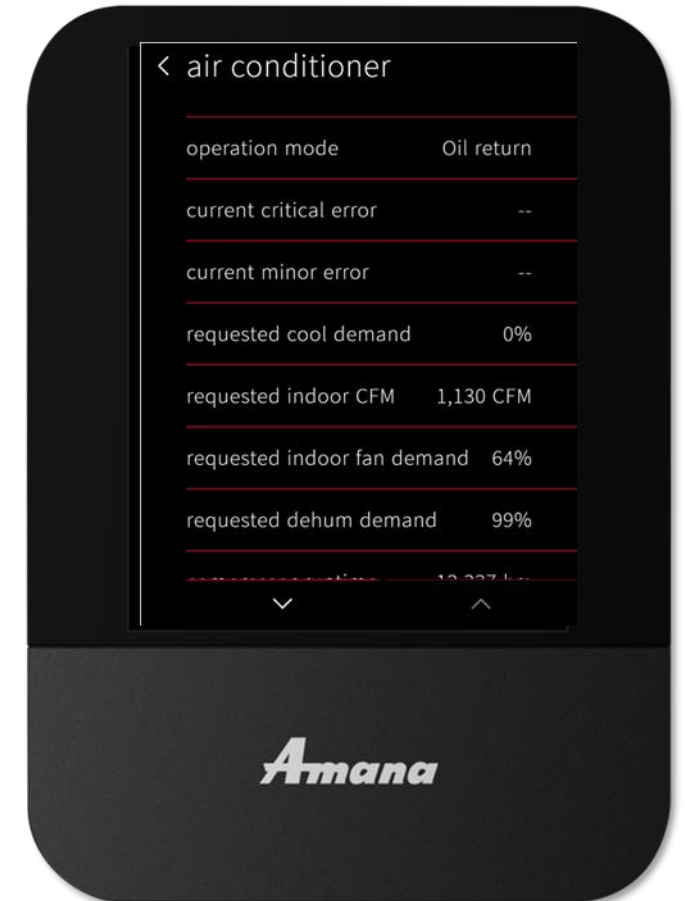
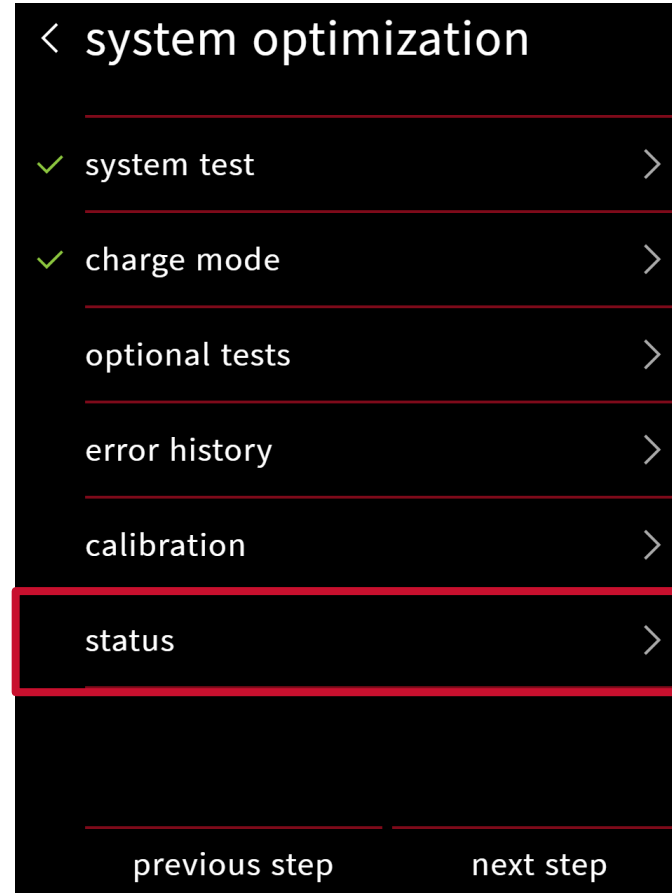

Full Set-up

Step 5 - preferences

- There are four preference settings to choose from in order to optimize your systems performance.
 - Cool/Heat
 - House settings
 - Dealer information
 - Reminders

Note: Changing preferences is not required, but reminders and dealer contact information should be inputted.

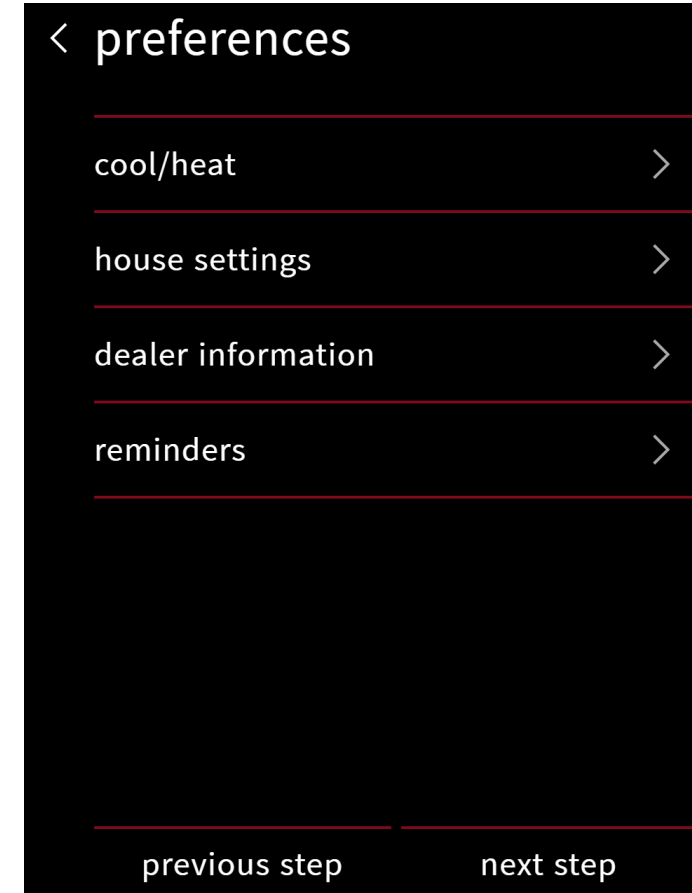
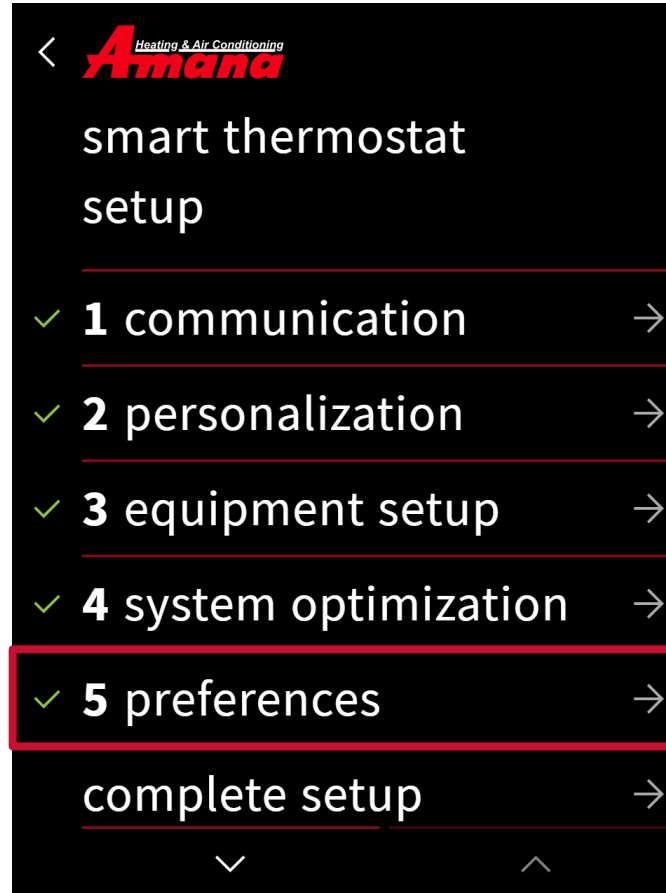

Full Set-up

Dealer information

- Selecting allows you to enter and review the dealer's information.

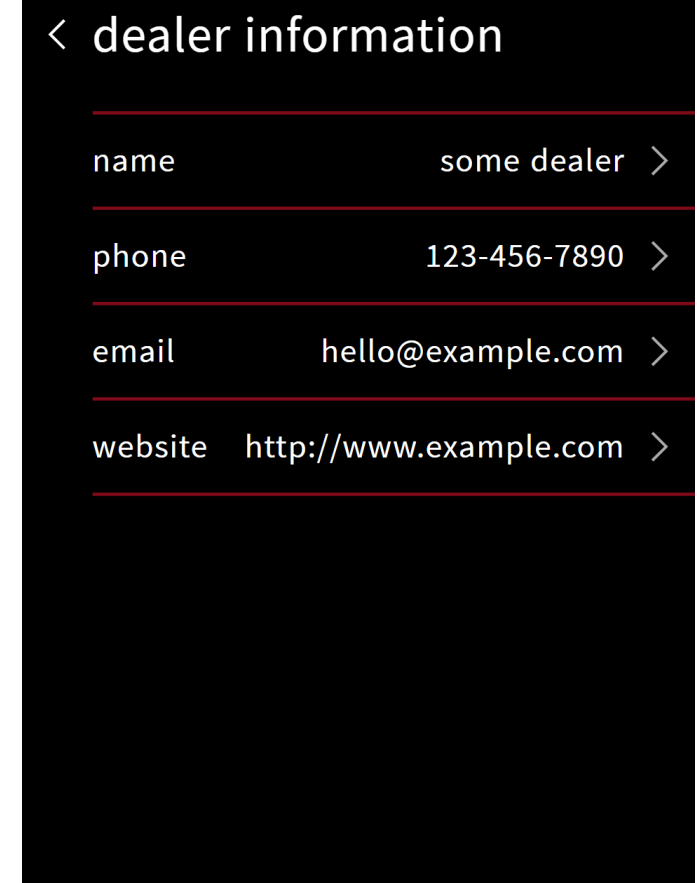
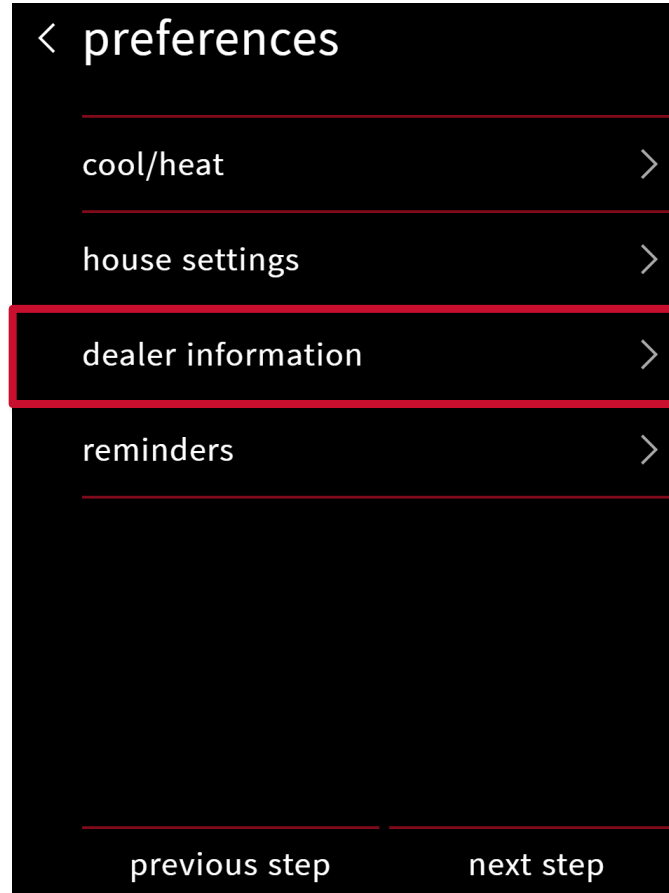



Reminders

- The number of reminders are based on the installed equipment with accessories.
- Once the equipment has been added, a **1 – 24-month** service reminder can be selected depending on the installed equipment.

Note: The homeowner can edit service reminders.

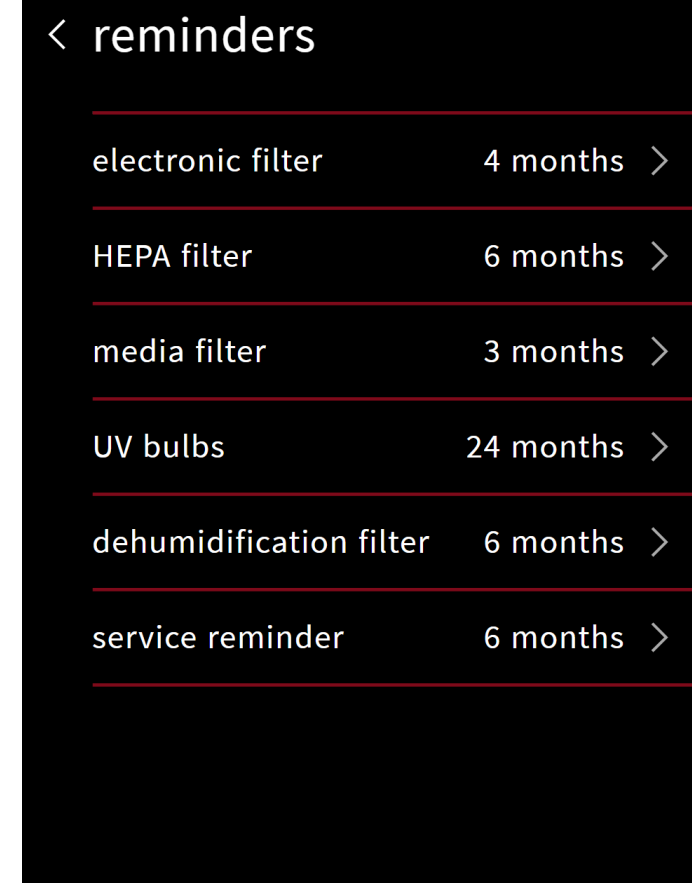
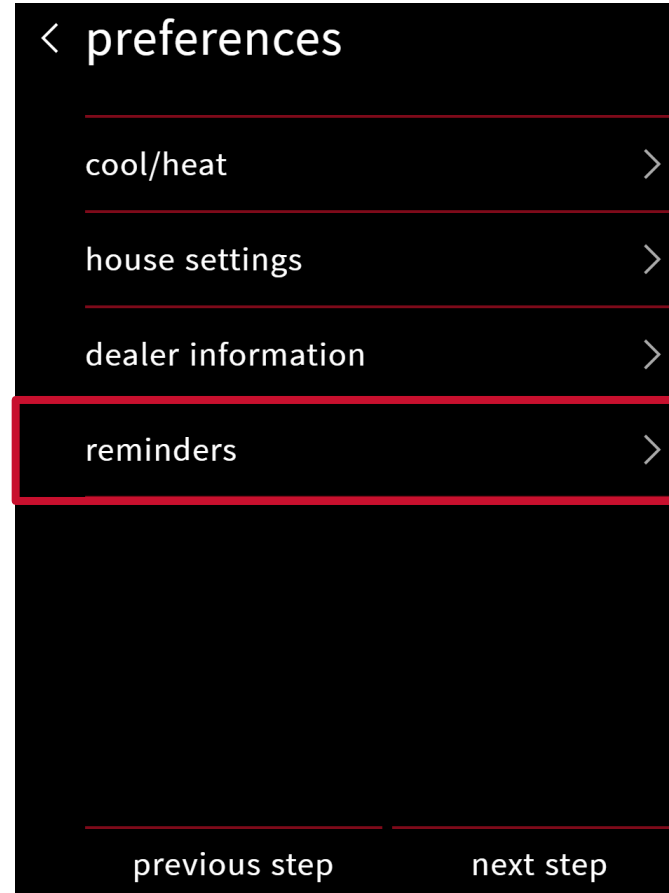

Full Set-up

Final step - complete set-up

- Selecting complete set-up will conclude the full set-up of the thermostat and display normal mode for you to navigate and verify settings.

Reminder: All steps must be reviewed before completing full set-up.

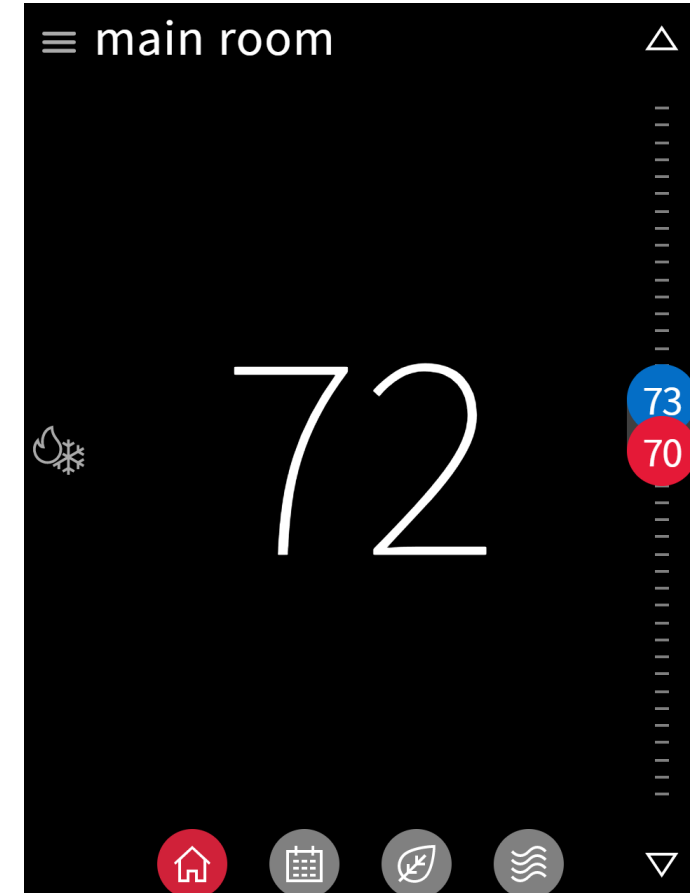
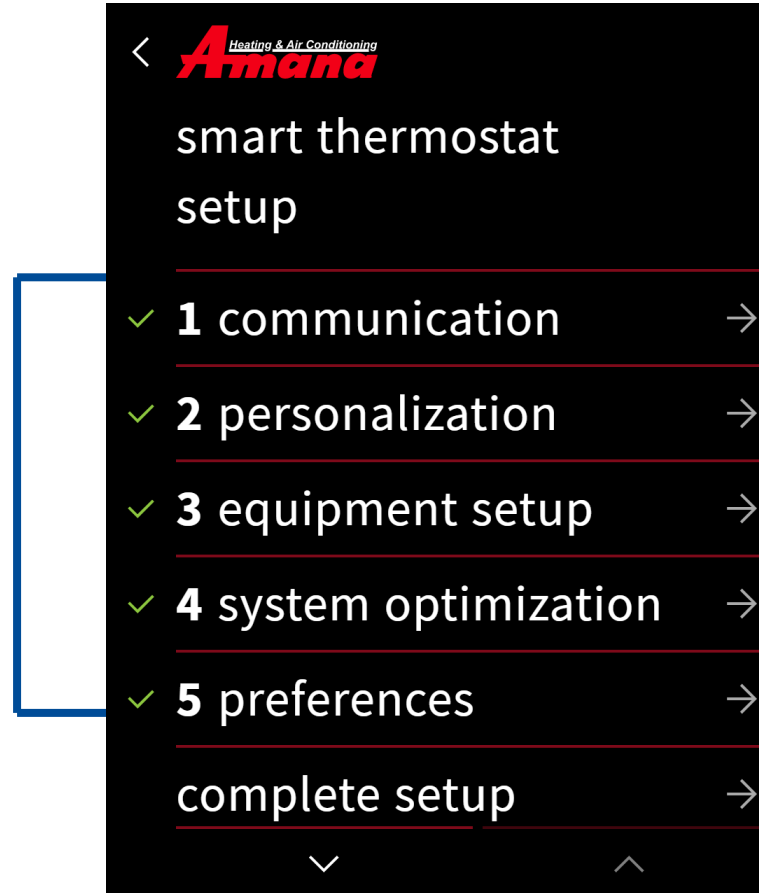

Agenda

Amana Smart Thermostat

System Configurations

Installing Amana Smart Thermostat

Commissioning Amana Smart Thermostat

Full Set-up

Dealer Navigation

Homeowner Navigation

Mobile Apps

Dealer Navigation

Dealer edit

- Navigating to **dealer edit** will allow you to access or revisit the installer set-up screen.
- Advanced adjustments to the Amana Smart Thermostat will be made here.

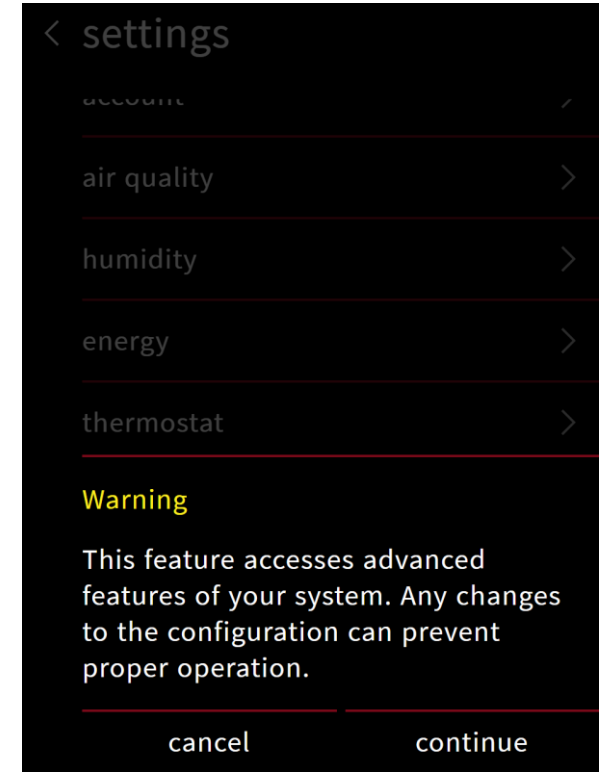
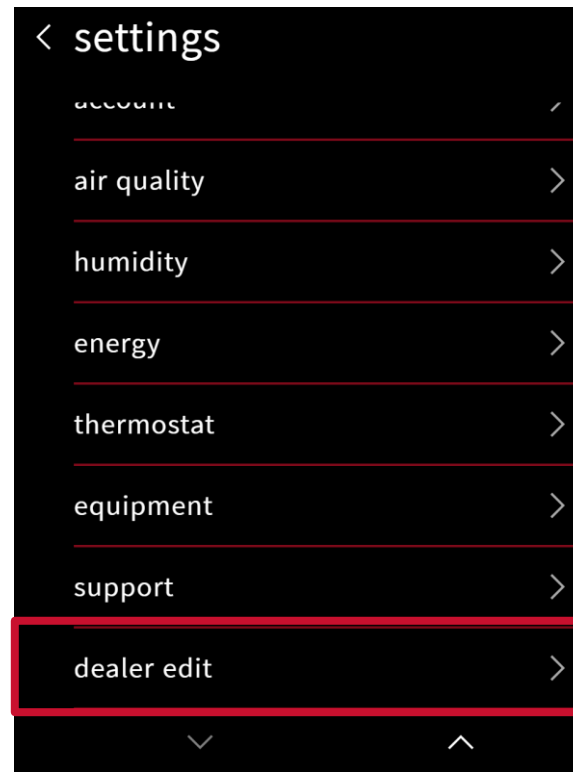
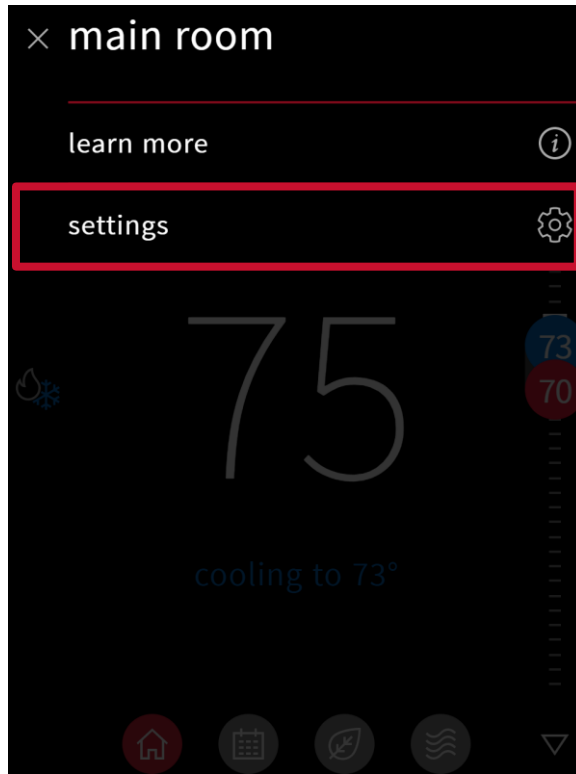
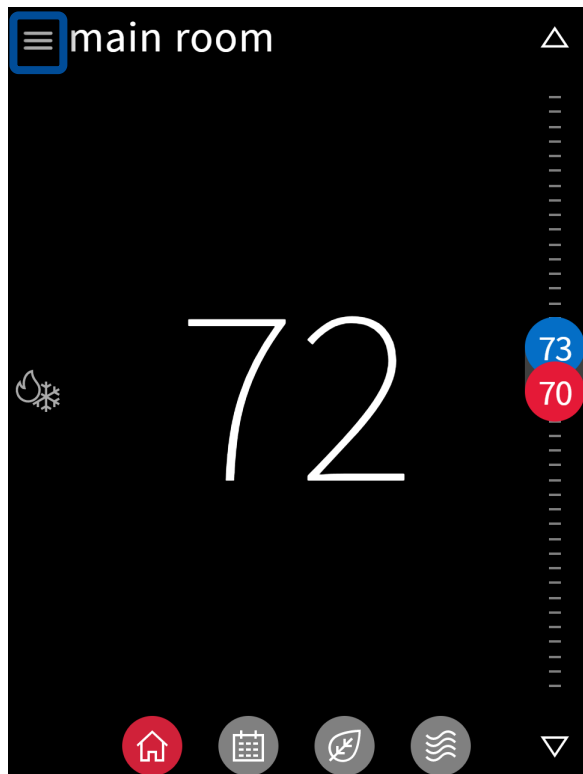

Dealer Navigation

- Acknowledging the prompt enables you to tap the learn more icon.
- The icon displays the installer code, giving you access to the installer set-up screens.

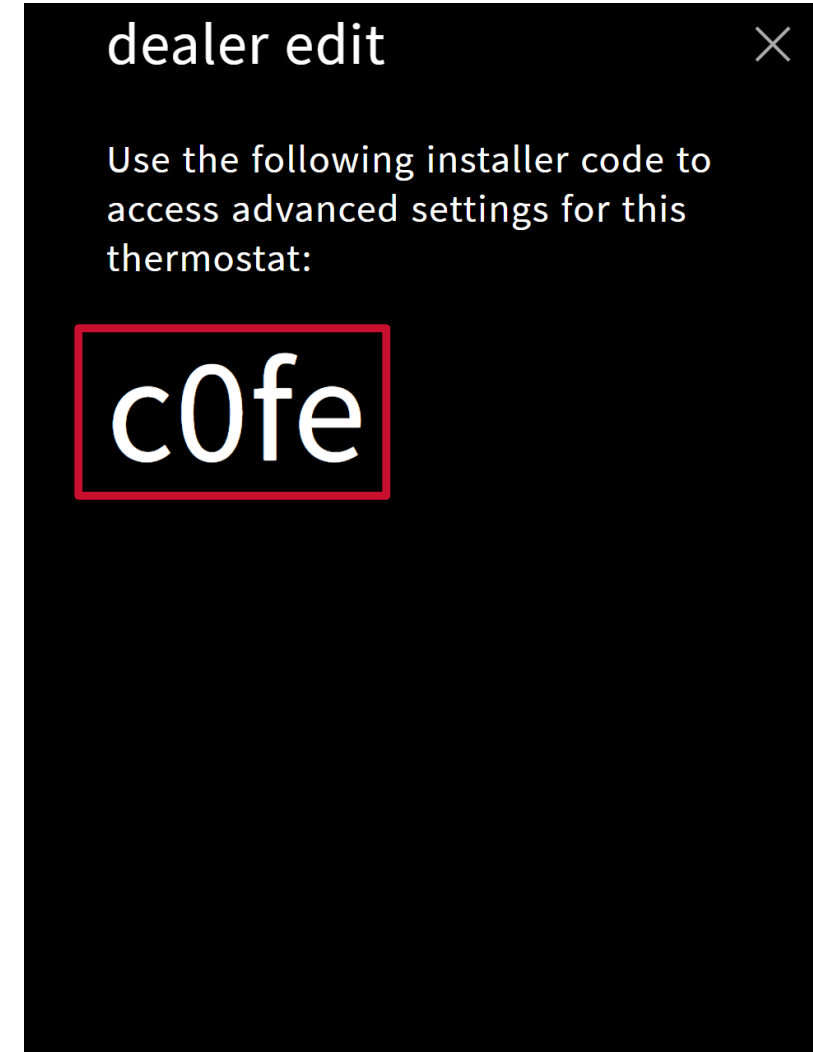
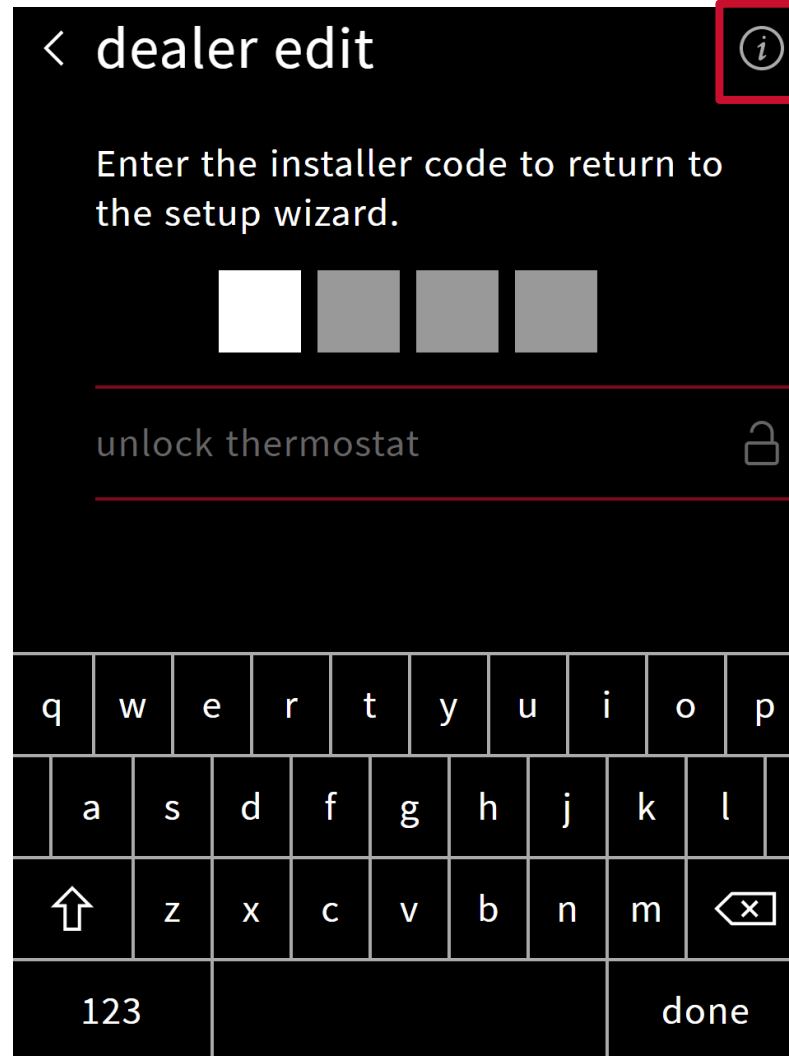

Agenda

Amana Smart Thermostat

System Configurations

Installing Amana Smart Thermostat

Commissioning Amana Smart Thermostat

Full Set-up

Dealer Navigation

Homeowner Navigation

Mobile Apps

Homeowner Navigation

Normal mode

- Normal mode allows you to view messaging, temperature, and access settings to adjust parameters placed by the installer.
- Navigating is accomplished by tapping icons.

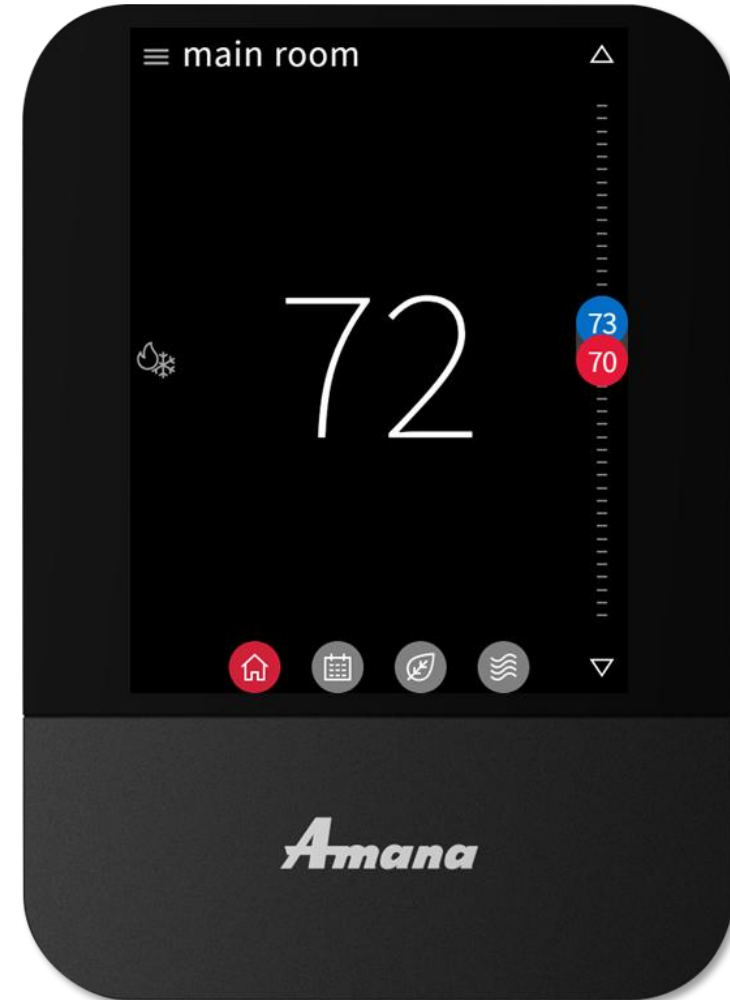

Homeowner Navigation

Adjust control

- Tapping the system mode icon allows you to select:
 - Auto. (cool & heat)
 - Cool.
 - Heat.
 - Off.
 - Emergency heat. (heat pump only)
- Tapping the arrow will adjust setpoints that are displayed. You can also tap, hold, and slide the setpoint icons to the desired temperature.

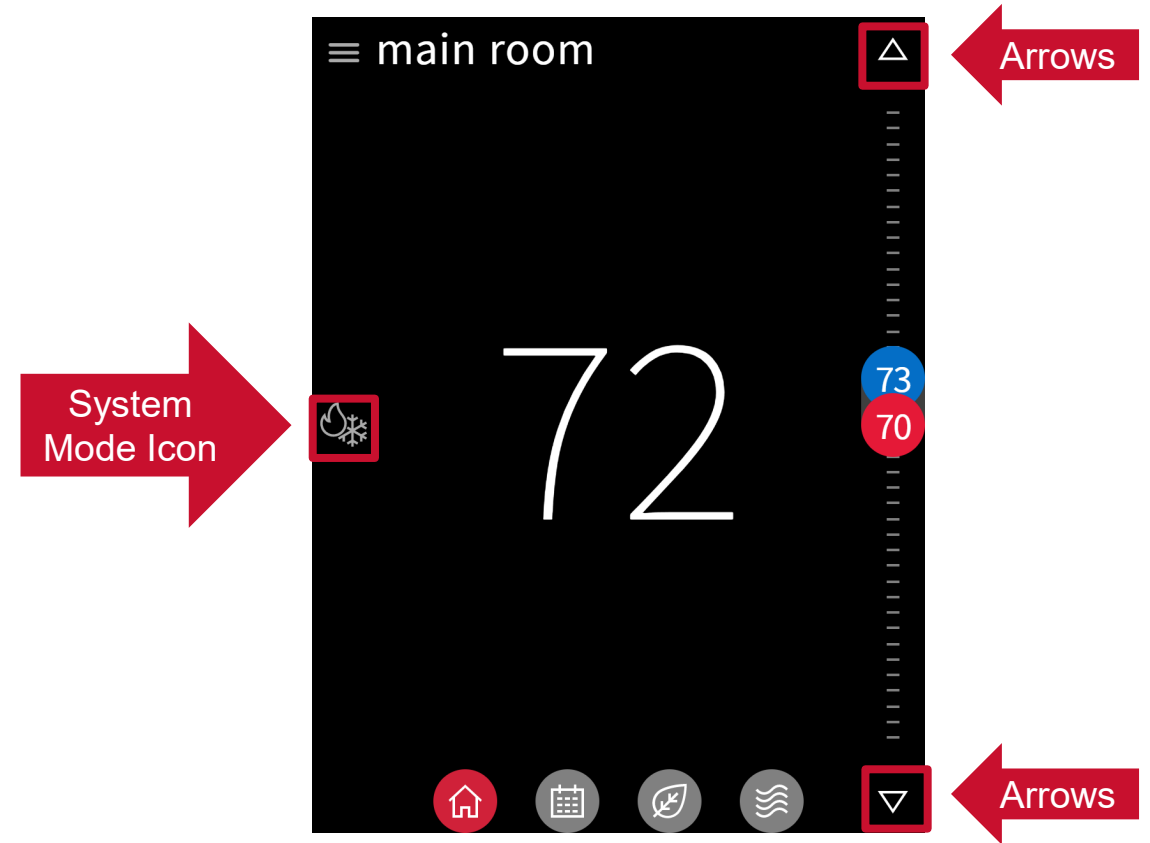

Homeowner Navigation

Schedule

- The schedule is presented as 7 days, displaying one day at a time, with 24 hours fitting on the screen.
 - 4 events can be scheduled in a 24-hour period.
- You can use the drop-down menu or swipe to enable schedule editing.
- Copy and paste is a feature that makes scheduling seamless.

Note: Unlike other screens, scheduling requires saving edits before exiting the mode.

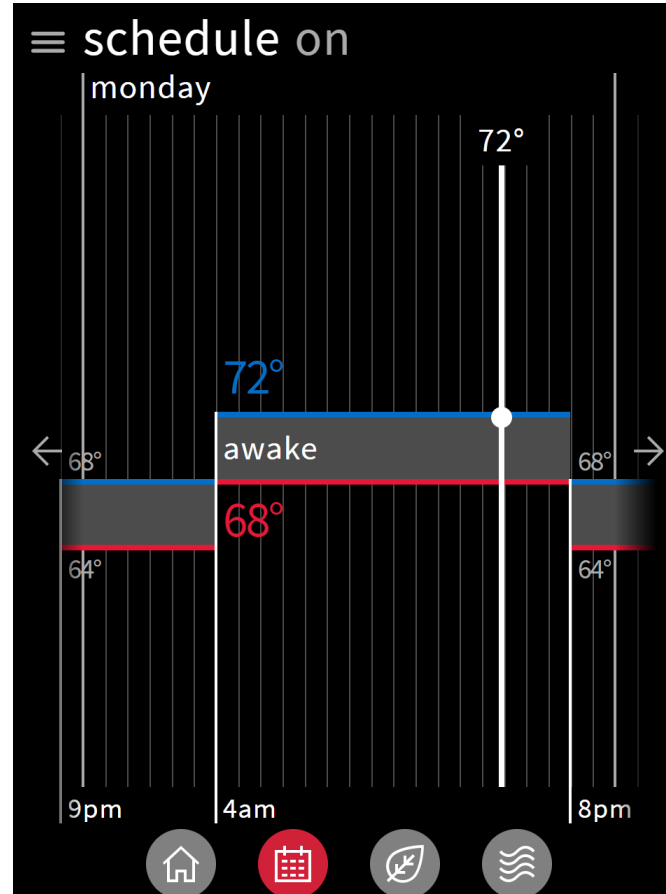

monday

awake
4:00 am 68°/72°

sleep
8:00 pm 64°/68°

copy day

to:

s m t w t f s

cancel paste

Homeowner Navigation

Away

- The away screen displays the current state (on/off) and the away cooling/heating setpoints used when away is on.
 - on/off is selected from drop down menu.
- User can change the values of the setpoints by dragging the numbers or the comfort range up and down.
- With the mobile application, enabling geo-fencing will automatically switch to away mode when **outside** the radius.
 - Settings must be configured in the mobile application.

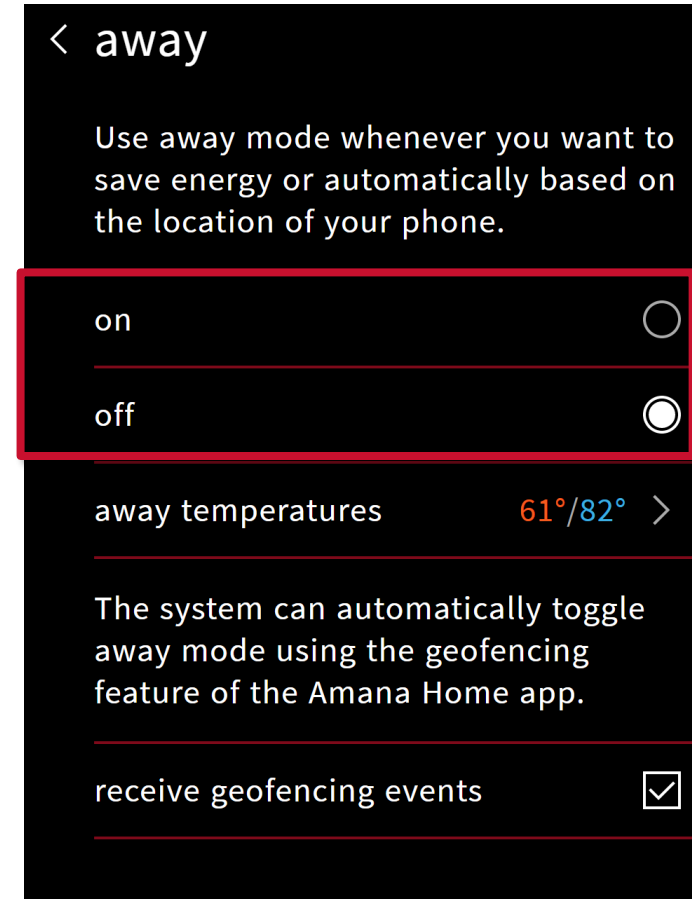
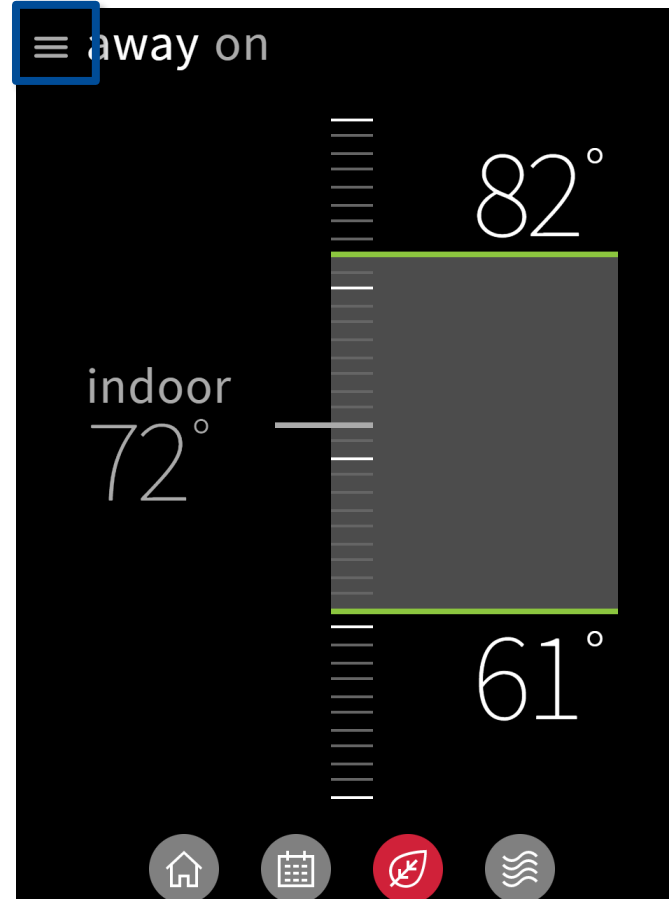

Homeowner Navigation

Air quality

- The air quality screen displays **indoor air** quality levels, **outdoor air** quality, and **weather** (when connected to the internet and paired with the app.)
 - The indoor air quality is based on filter life cycle and humidity values.

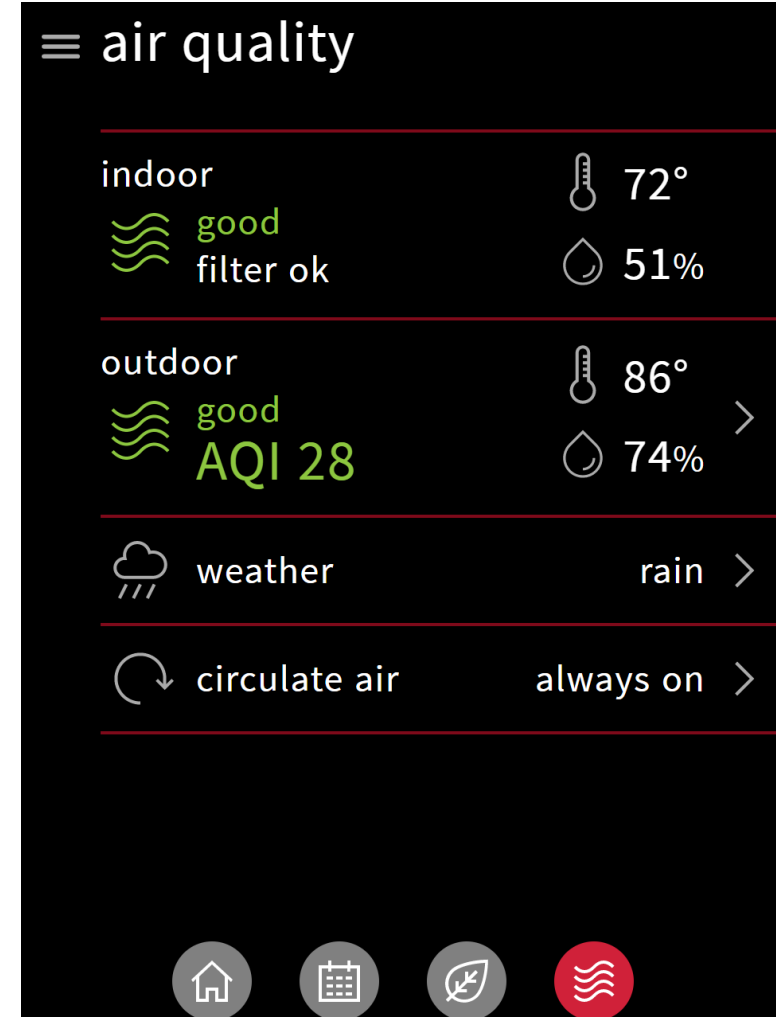

Homeowner Navigation

Settings

- Settings gives you access to additional supporting features:
 - Display.
 - Adjust and enable visual features.
 - Comfort.
 - Set target humidity.
 - Configuration.
 - App. account setup
 - Dealer information
 - Date & Time
 - Enable messages/view alerts
 - System components
 - Home Wi-Fi

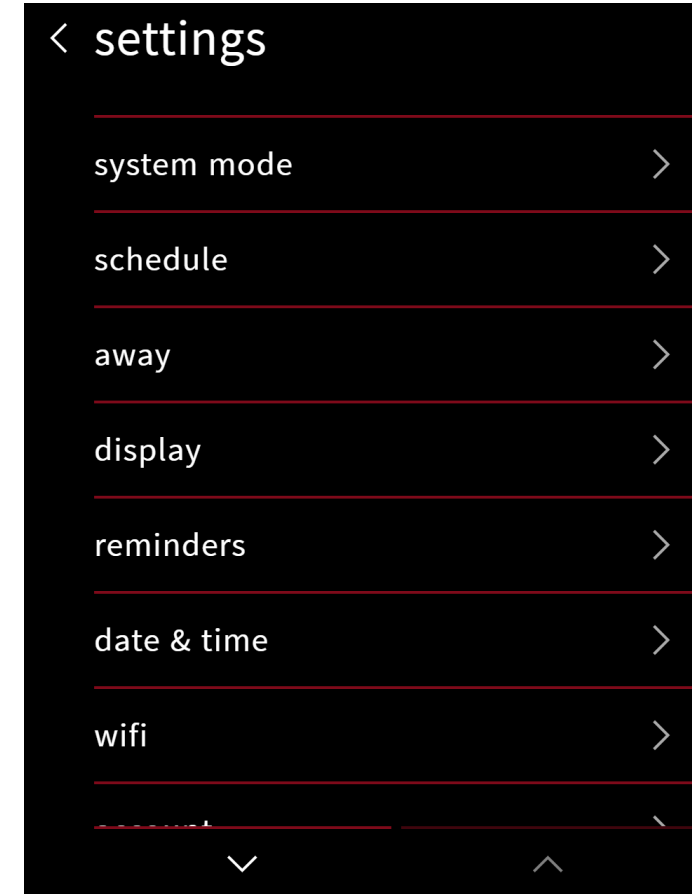
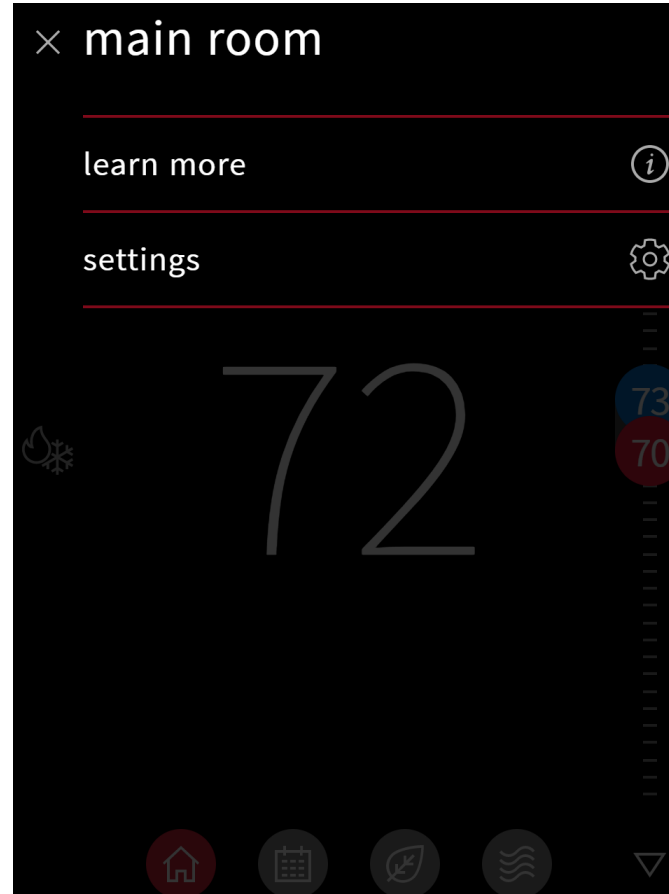

Agenda

Amana Smart Thermostat

System Configurations

Installing Amana Smart Thermostat

Commissioning Amana Smart Thermostat

Full Set-up

Dealer Navigation

Homeowner Navigation

Mobile Apps

Account Set-up



- Setting up an account is a four-step process.
 1. Downloading the application from your IOS or Android application store.
 - Creating the account.
 2. Confirming your account.
 3. Adding the thermostats' location.
 4. Connecting the app to the thermostat.

Note: A mobile device, the **Amana Smart Thermostat** connected to **Wi-Fi** that is wired to a **communicating system** and a valid **email address** is needed to create a mobile account.

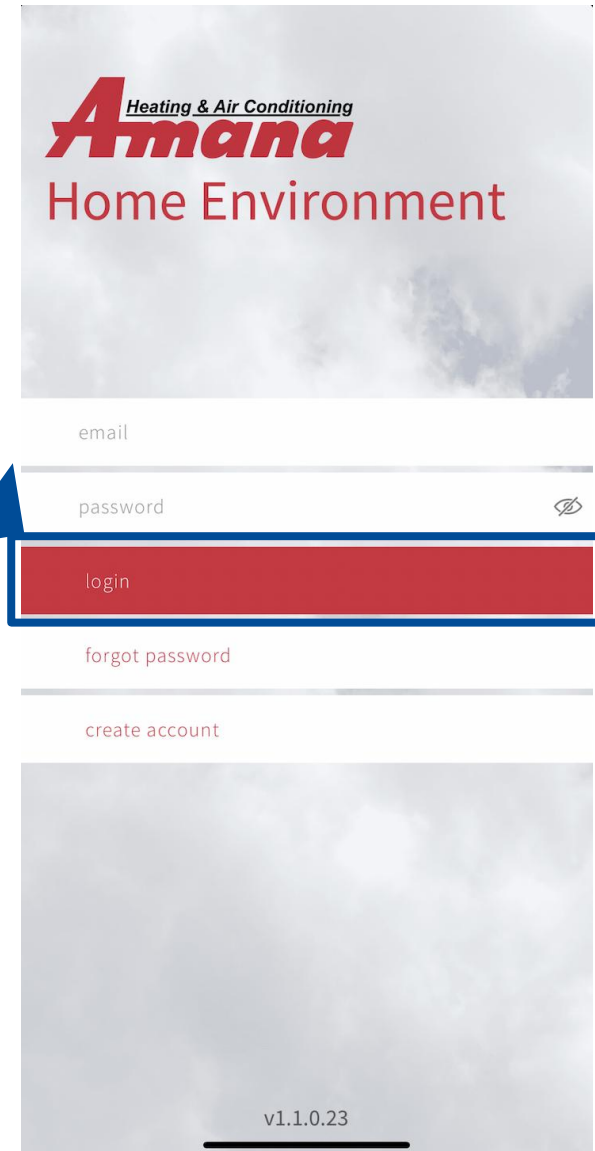
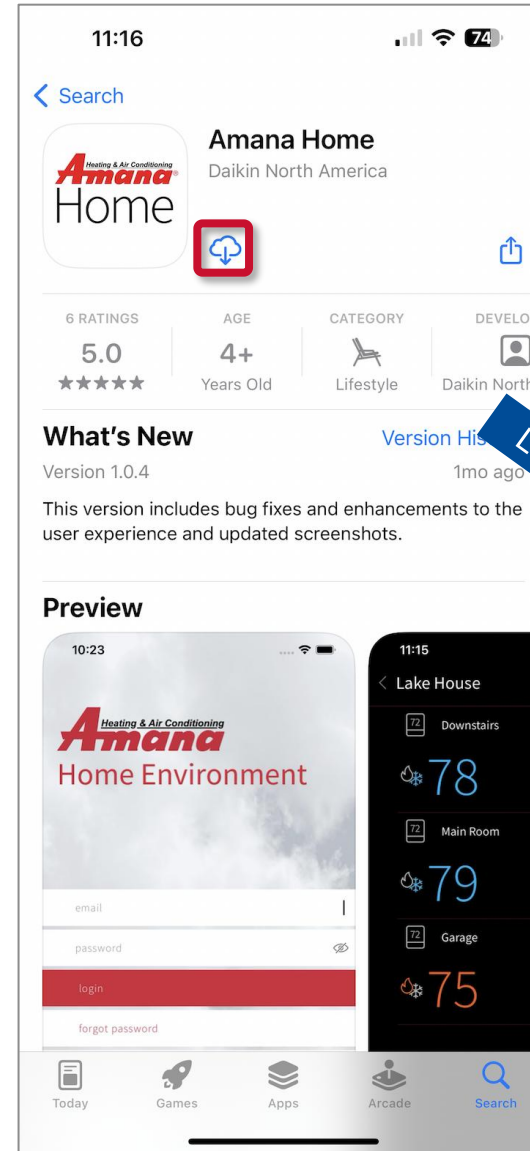

Step 1 - Create The Account

- Tapping create account button of the login screen will start the process.
- Before agreeing, read the terms and service, privacy statement, and other notices.
- Fill in your name, valid email address, and password.

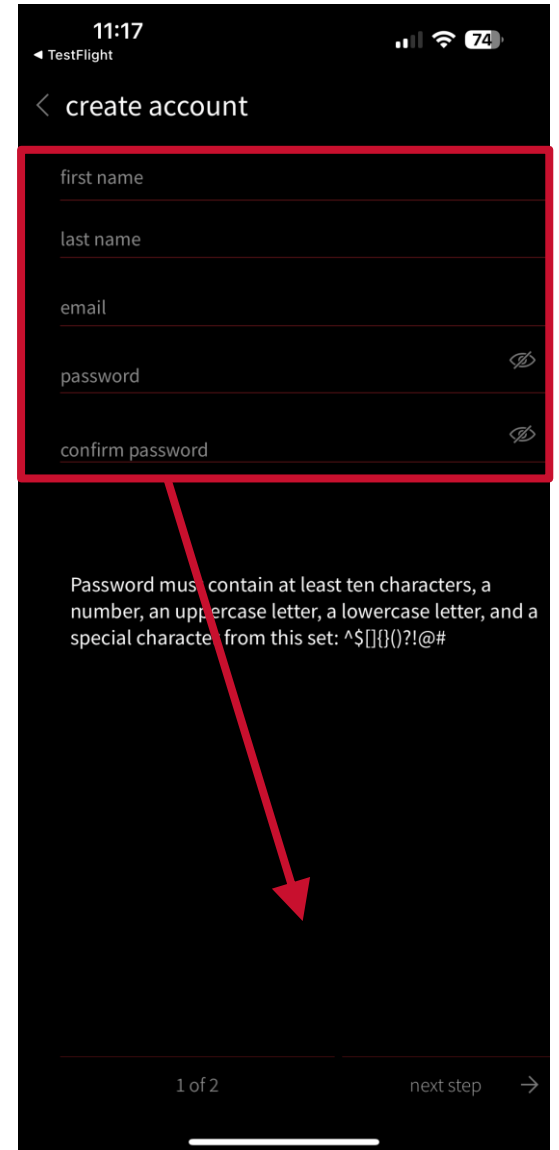
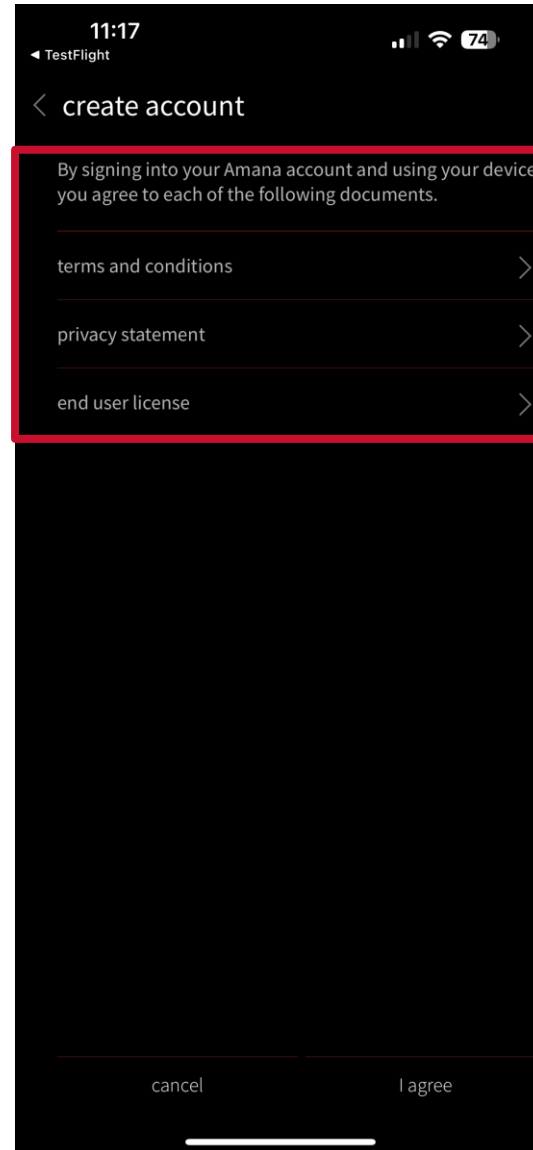
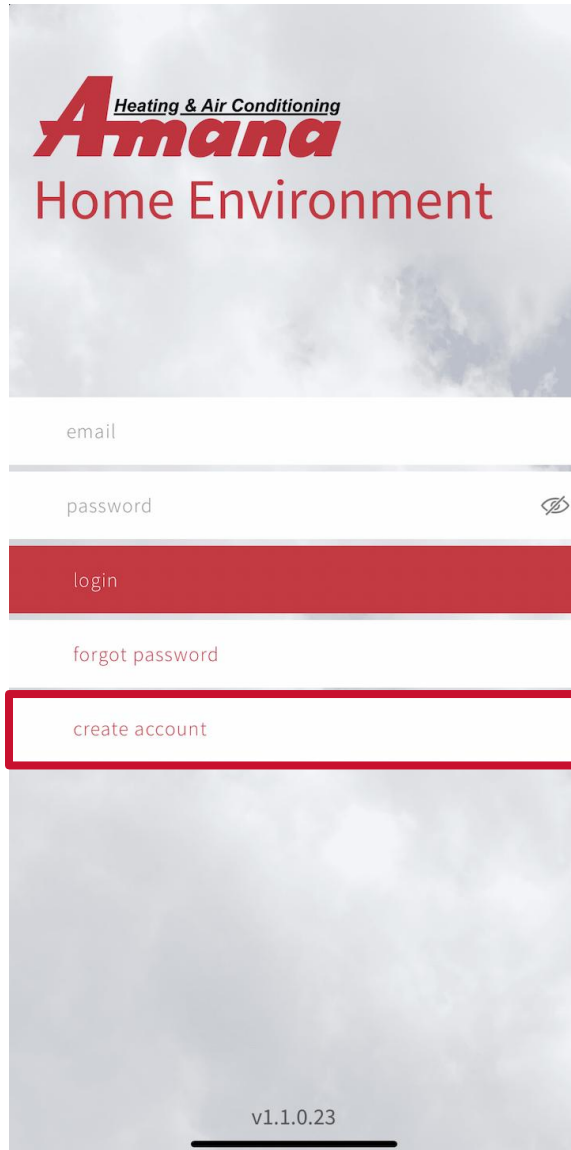

Step 2 - Confirming The Account

- You will be prompted to access the email address you provided when creating the account.
- A welcome email will appear in your inbox providing a six-digit code.
- Entering the six-digit code on your phone app. will allow you to continue.

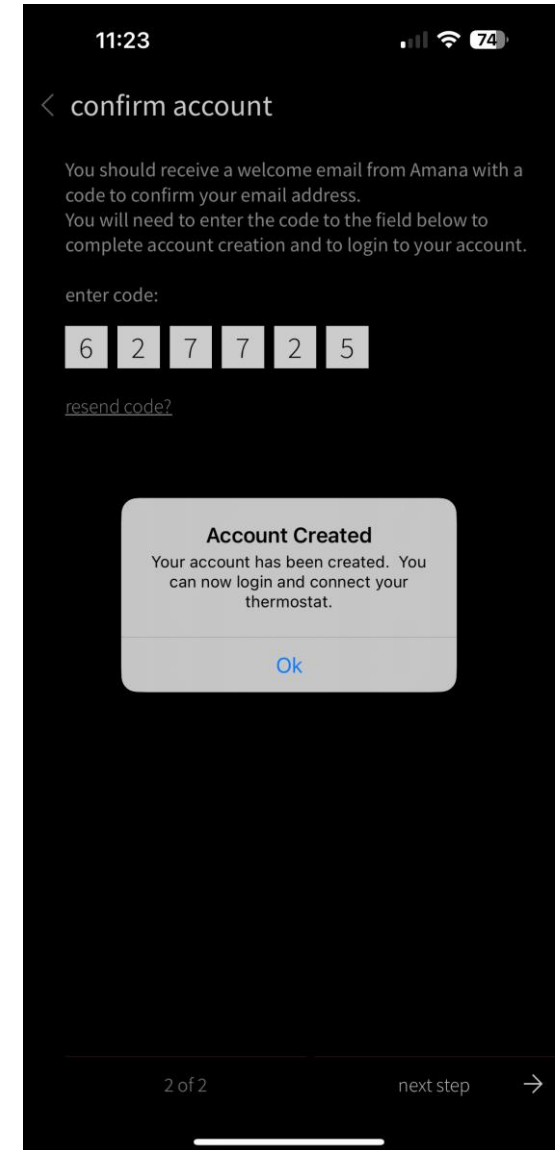
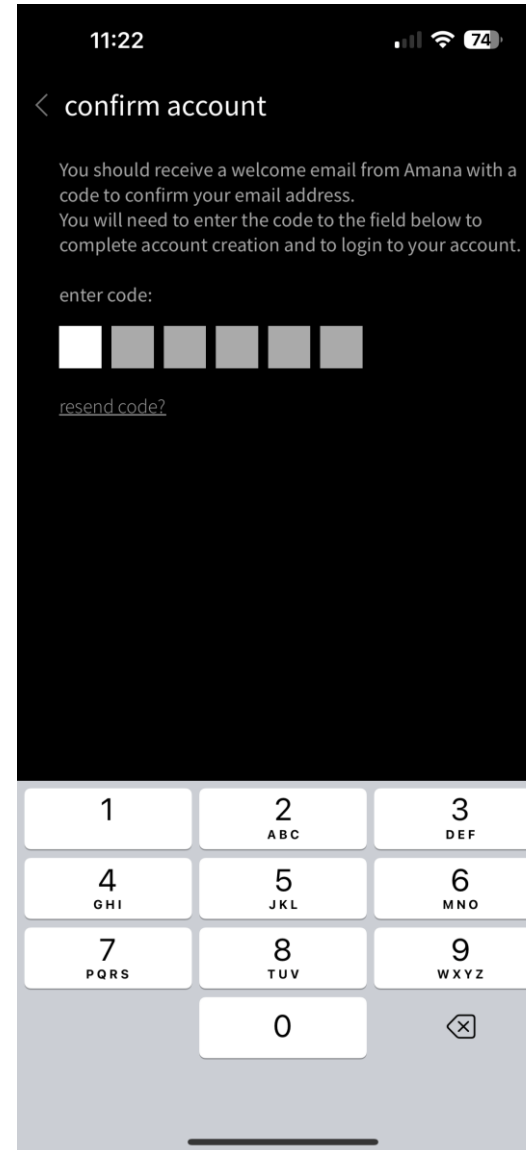

Step 3 - Adding The Thermostats Location

- Enter the email and password associated to your mobile account and tap the login button.
 - If you have forgotten your password, tap the forgot password link to recover information via email.
- Type the location name and address of where the thermostat is located to gather accurate information.

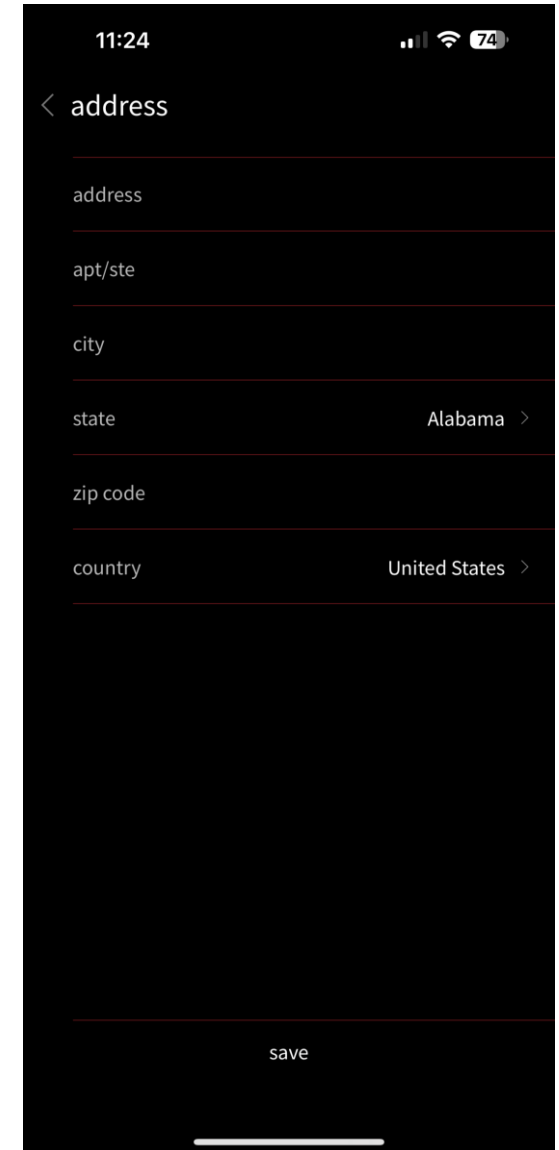
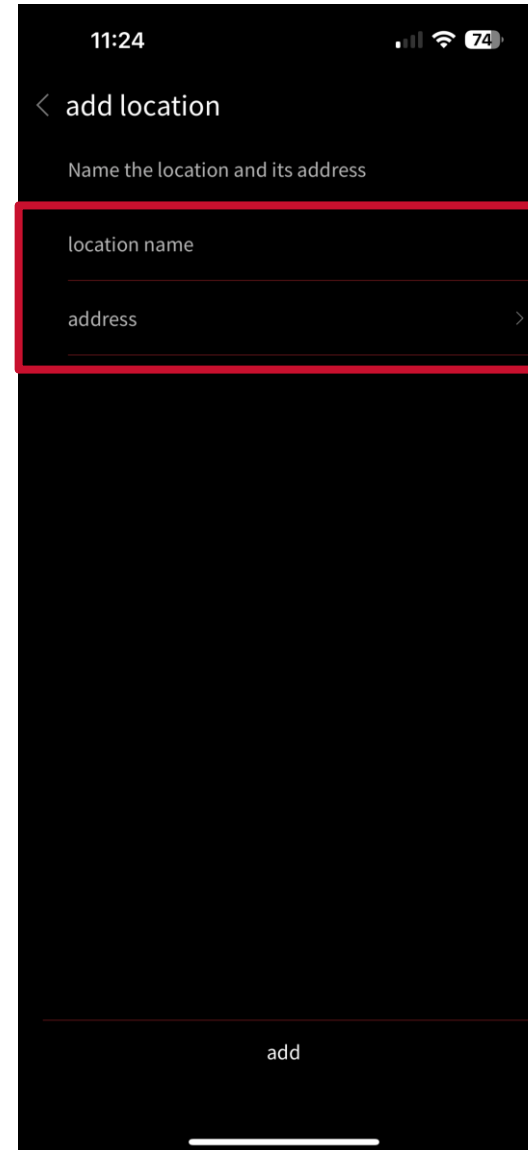
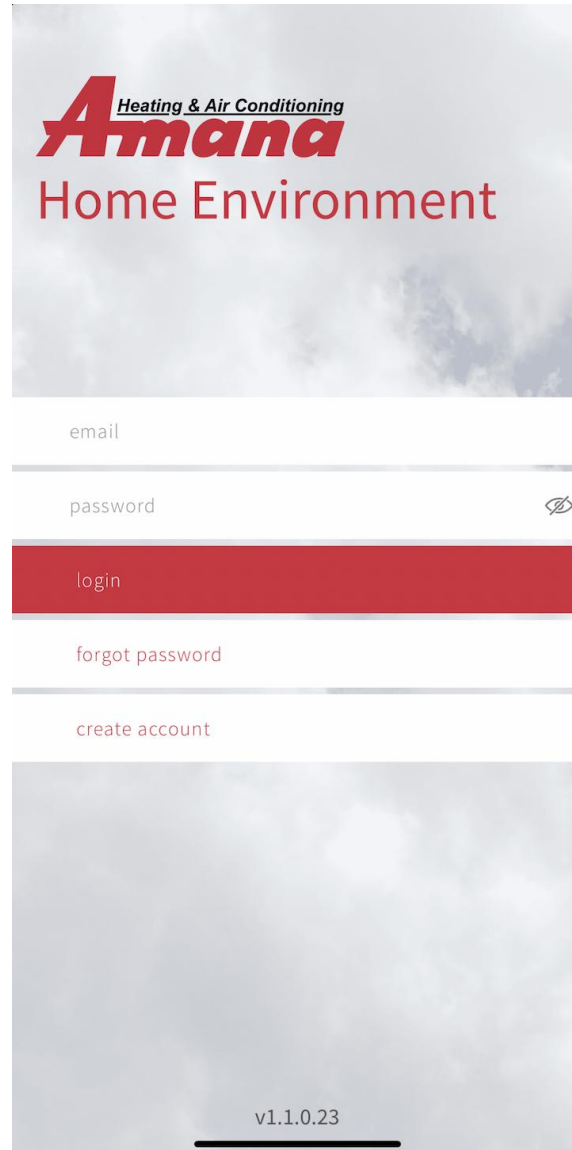

Step 4 - Connecting The App. To The Thermostat

- With Wi-Fi enabled on your thermostat, access your account to retrieve the six-digit code.
- Type the six-digit code displayed on your thermostat into the space provided on the mobile app.
- Tap connect to continue and operate the Amana Smart Thermostat from your mobile device.

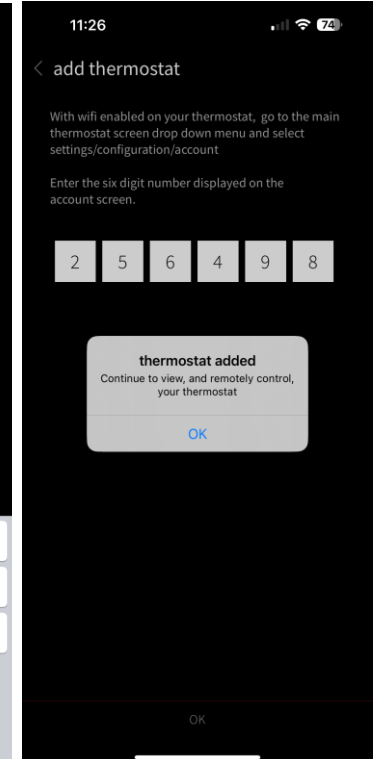
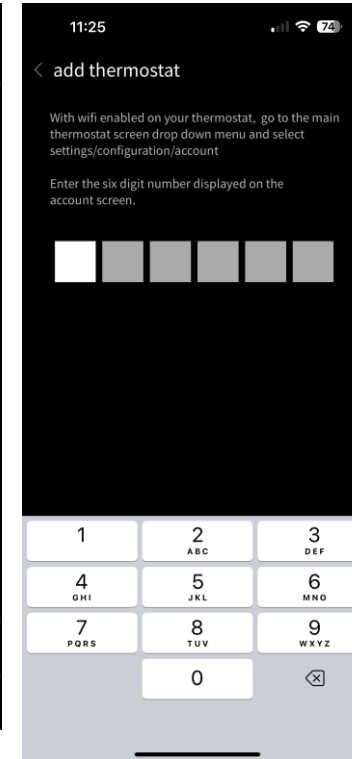
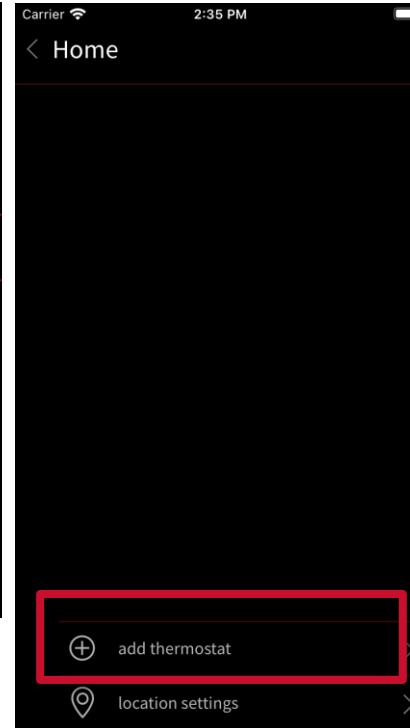
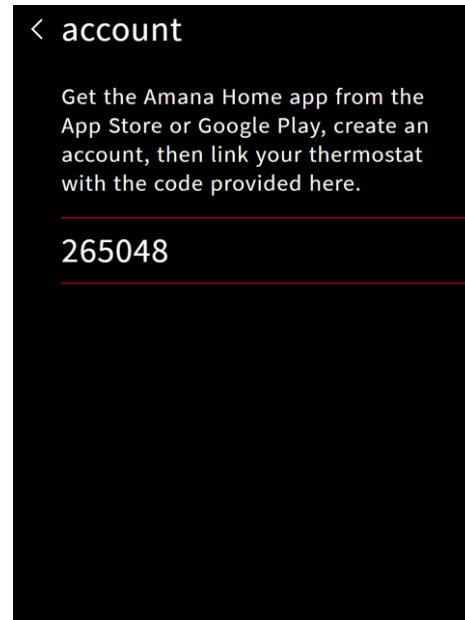

Mobile App.

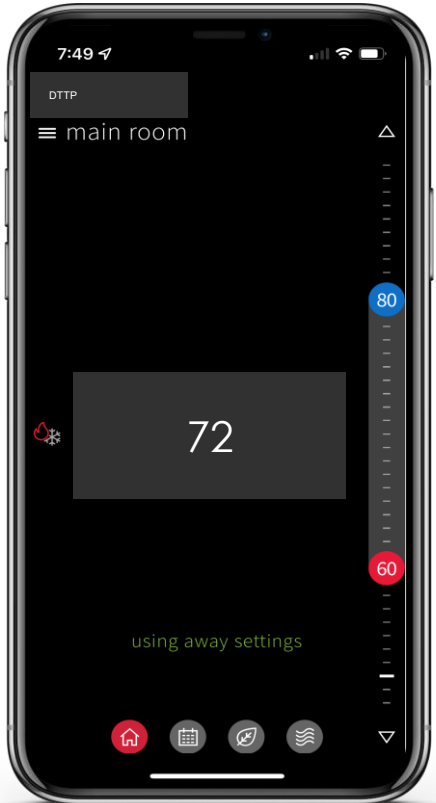
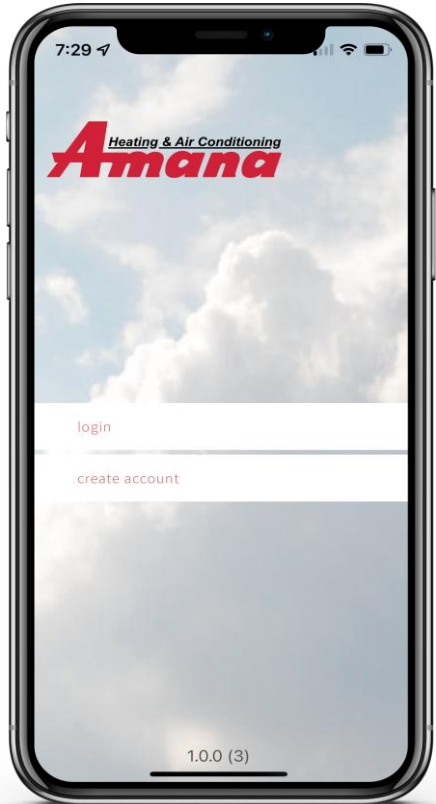
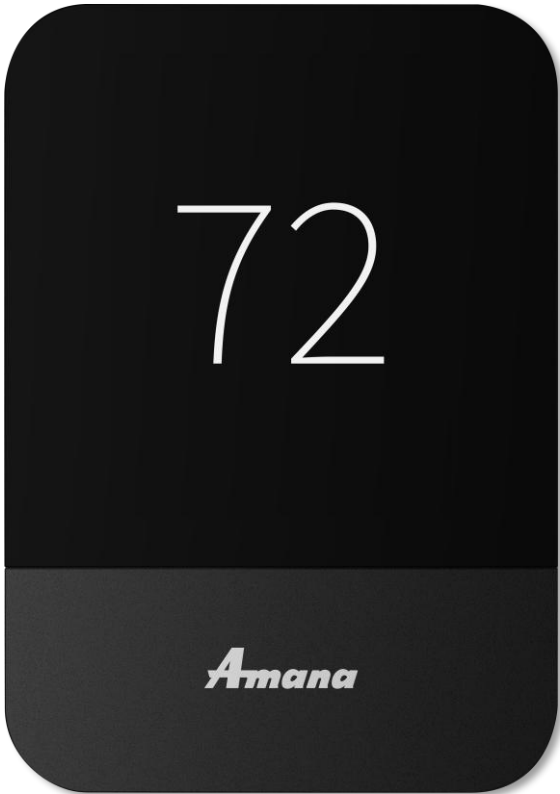

Visit <https://amana-hac.com/resources> for additional information

Technical
Support

Technical Service Advisor

Clint Gilliland

405-740-5904

cgilliland@ssdhvac.com

Amana Factory Support

1 (888) 593-9988



A **Heating & Air Conditioning** ***Amana***®



© 2022 Daikin Comfort Technologies North America, Inc.
Amana® is a registered trademark of Maytag Corporation or its related companies and is used under license.
All rights reserved.